

REV.	ECN NO.	DATE	SIGN	DESCRIPTION
B	LE3-710143	2006/12/15	Gao Ling	Move O-ring to ZSE00100824
C	LEN1350290	2013/05/31	Yulong	Update the Dimension

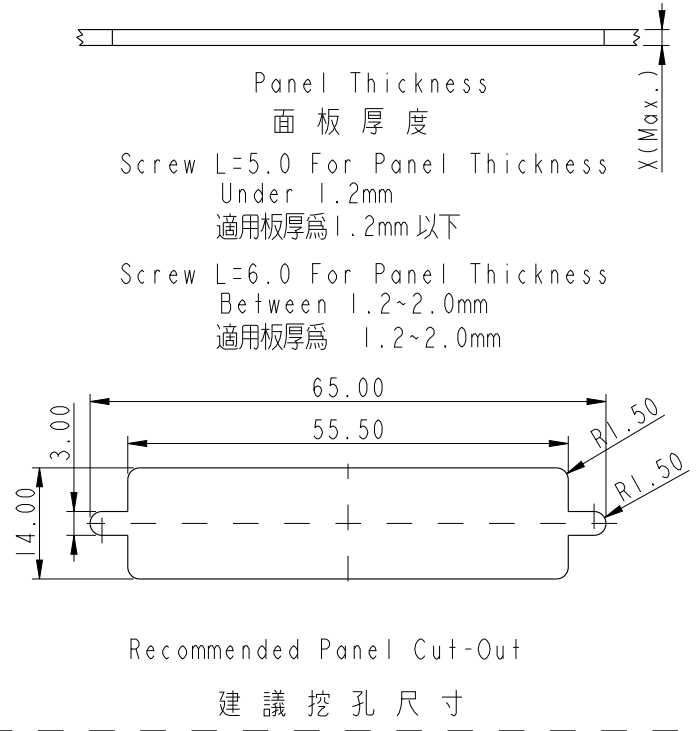

- Note:
- * \varnothing Important Dimension.
 - * Waterproof Rate : IP67
 - * Do Mating Test After Glued
點膠後, 須作對插測試
 - \triangle * D-SUB Conn. : Black Core, PBT
 - \triangle * Plastic Jacket : Black, Nylon+GF
 - \triangle * Pin : Copper Alloy , Gold Plated
 - * Ring : Light Blue, Silicone
 - \triangle * Screw : Copper Alloy, Nickel Plated, #4-40 UNC

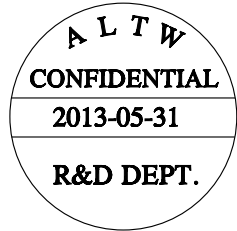
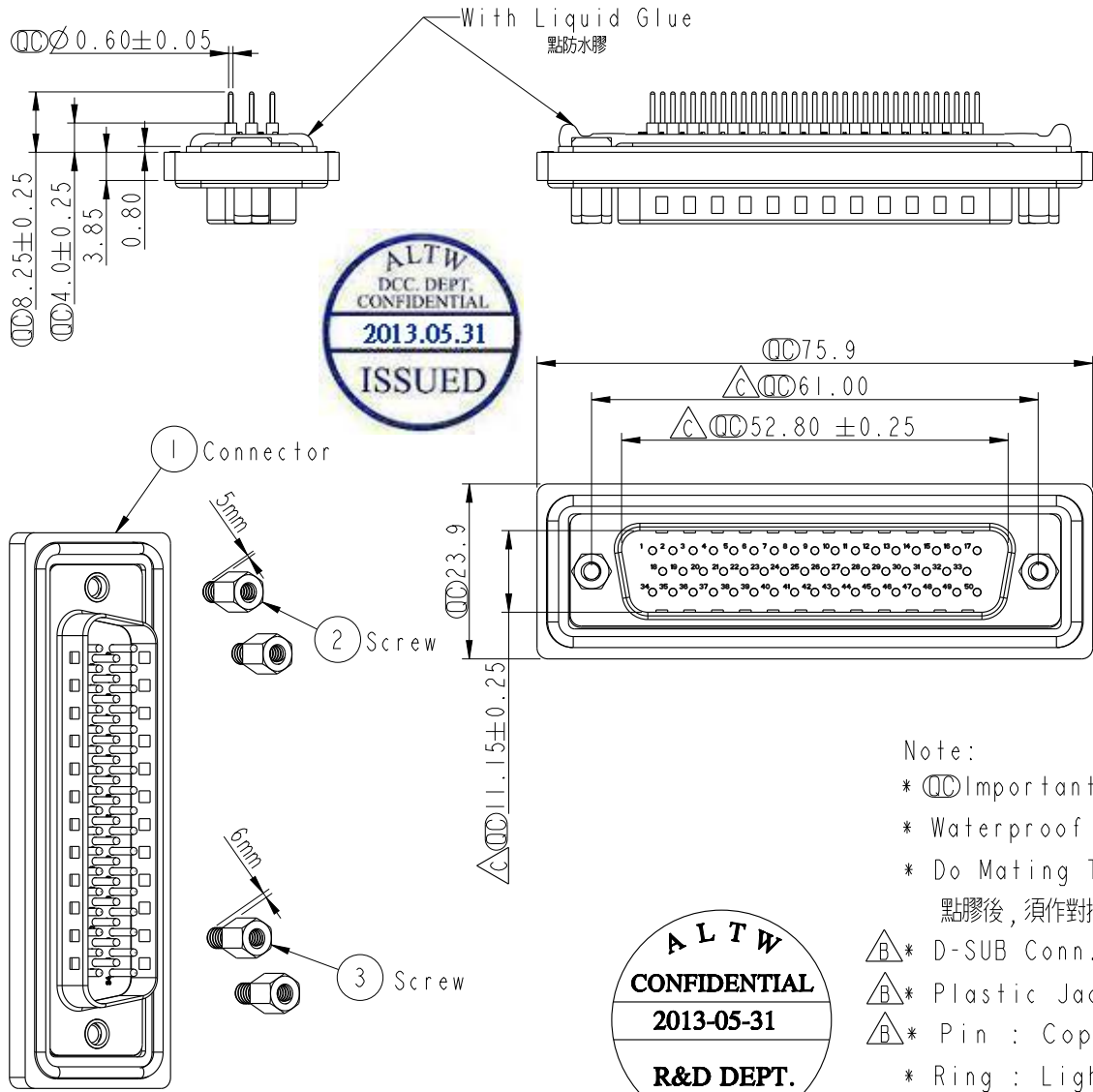
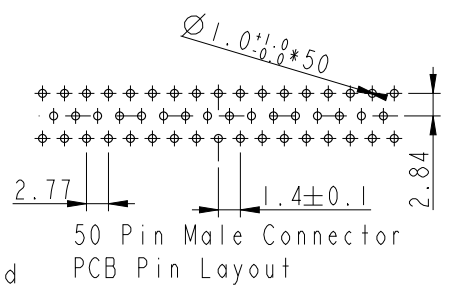

UNIT: mm			TITLE D-SUB Conn. \triangle Panel Screw DB50P M Conn M Pin
TOLERANCE .X ±0.25 .XX ±0.1 .XXX ±0.05 ANGLES ±1°	SCALE 1:1	SIZE A4	SHEET 1 OF 1
REV. C	WC-REV. A.3	\varnothing : Inspection item	

Amphenol LTW
安費諾亮泰企業股份有限公司

ITEM NO. SDB-50PMMP-SL7001	DRAWN BY Yulong_wang	DATE 2013-05-31
DWG NO. SDB-50PMMP-SL7001	CHECKED BY Victor	DATE 2013-05-31
CUSTOMER ALTW	APPROVED BY Maslow	DATE 2013-05-31

THIS DOCUMENT IS SUBJECT TO CHANGE WITHOUT NOTICE. IT IS CONFIDENTIAL AND A PROPERTY OF Amphenol LTW. DISCLOSURE TO THIRD PARTY HAS TO BE AUTHORIZED BY Amphenol LTW.