

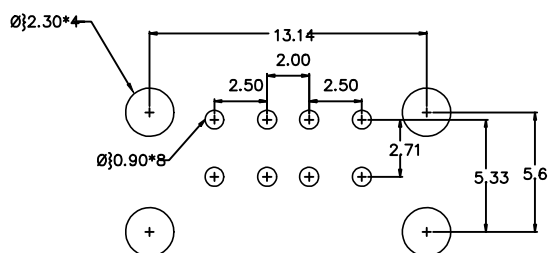

REV.	ECN NO OR DESCRIPTION	REVISED	DATE

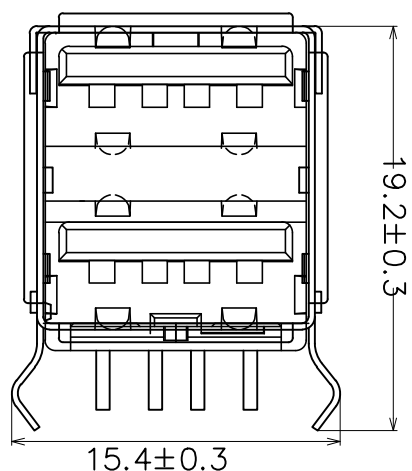
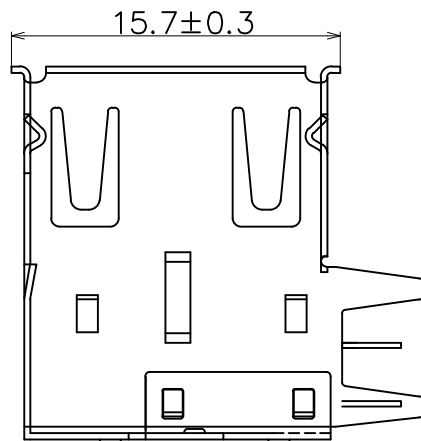
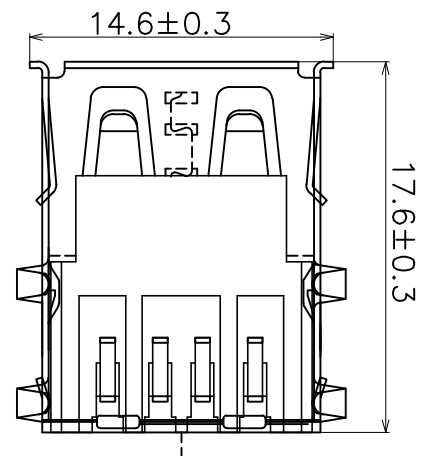

RBCOMMENDBD P.C.B PATTBRN LAY OUT

规格说明: Specifications:

电气特性: Electrical:

1. 额定电流: Current Rating
1.5A/contact terminal
2. 额定电压: Voltage Rating
30V DC
3. 接触阻抗: Contact Resistance
30 milliohms MAX
4. 耐电压: Dielectric Withstanding Voitage:
500 V AC AT Sea Level
5. 绝缘阻抗: Insulation Resistance:
1000MEGA ohms MIN

物理性能: Mechanical:

1. 插拔力: Cnector Mate and Unmate Force
Mate force: 3.75kgf(MAX)
Unmate force: 1.02kgf(MIN)
2. 端子保持力: Terminal Retention
1.2kgf(MIN)

原材料: Matorial:

1. 塑胶: Housing:
Hing Temperature Tnermaplastics,
UI 94V-0 PBT/LCP White/Black
2. 端子: Contact: Copper Alloy C2680
3. 外壳: Shell: Copper Alloy C2680/SPCC

电镀: Finish:

1. 端子: Contact: Plated Gold in Mating Area;
Tin On Solder Talls
2. 外壳: Shell:
Nickel Plating

UNLESS OTHERWISE SPECIFIED TOLERANCES		东莞市汉博电子科技有限公司 DONGGUAN HANBO TECHNOLOGY CO., LTD		
DECIMALS:	ANGLES:	TITLE	USB AF 90度双层半包弯脚卷边	
X :±0.30	X :±2°	DWN	xiong	PART NO. USB-U264-BJS
X.X :±0.20	X.X :±1°	CHKD	lee	SCALE:1:1 UNIT: mm
X.XX :±0.10		APVD	wang	SIZE: A4 SHEET:1OF 1 REV: A4
CUSTOMER COPY				