

LN239N3T5G

30V, Single N-channel Trench MOSFET

1. FEATURES

- Fast switching
- Low RDS(ON)
- Trench MOSFET technology
- This is a Pb Free Device
- We declare that the material of product compliance with RoHS requirements and Halogen Free.

2. APPLICATIONS

- Low Side Load Switch
- Level Shift Circuits
- Gate to Source ESD protected, HBM >2KV
- Portable Applications i.e. DSC, PDA, Cell Phone, etc.

3. DEVICE MARKING AND ORDERING INFORMATION

Device	Marking	Shipping
LN239N3T5G	N4	10000/Tape&Reel

4. MAXIMUM RATINGS(Ta = 25°C)

Parameter	Symbol	Limits	Unit
Drain-to-Source Voltage	VDSS	30	V
Gate-to-Source Voltage	VGS	±8	V
Drain Current (Note 1)	ID	1	A
Steady State (TA = 25°C) (TA = 100°C)		0.8	
Power Dissipation (Note 1)	PD	225	mW
Steady State			
Pulsed Drain Current (tp = 10 μs)	IDM	3.7	A
Operating Junction and Storage Temperature Range	TJ , TSTG	-55~+150	°C

5. THERMAL CHARACTERISTICS

Parameter	Symbol	Limits	Unit
Junction-to-Ambient - Steady State (Note 1)	RθJA	390	°C/W

Note 1: Surface-mounted on FR4 board using 1 in sq pad size (Cu area = 1.127 in sq [1 oz] including traces)

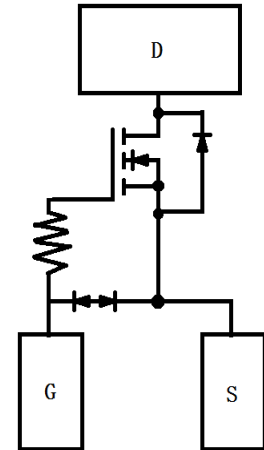
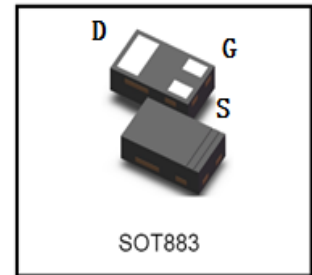

6. ELECTRICAL CHARACTERISTICS (Ta= 25°C)

Characteristic	Symbol	Min.	Typ.	Max.	Unit
STATIC CHARACTERISTICS					
Drain-Source Breakdown Voltage (VGS =0V, ID =250μA)	V(BR)DSS	30	-	-	V
Gate Threshold Voltage (VDS =VGS , ID =250μA)	VGS(th)	0.45	0.65	0.9	
Gate-Body Leakage Current (VDS =0V, VGS =± 8V)	IGSS	-	-	±10	μA
Zero Gate Voltage Drain Current (VDS =30V, VGS =0V)	IDSS	-	-	1	
Drain-Source On-Resistance (VGS =4.5V, ID = 500mA) (VGS =2.5V, ID = 300mA) (VGS =1.8V, ID = 100mA)	RDS(ON)	-	0.2	0.30	Ω
		-	0.3	0.40	
		-	0.4	0.50	
Diode Forward Voltage (IS =300mA, VGS =0V)	VSD	-	-	1.2	V
DYNAMIC PARAMETERS					
Total Gate Charge	(VDS =15V, VGS =4.5V, ID =1.0A)	Qg	-	1.3	nC
Gate-Source Charge		Qgs	-	0.16	
Gate-Drain Charge		Qgd	-	0.44	
Input Capacitance	(VDS =25V, VGS =0V, f=1MHz)	Ciss	-	99	pF
Output Capacitance		Coss	-	7.4	
Reverse Transfer Capacitance		Crss	-	5.2	
Turn-On Delay Time	(VDS =15V, VGS =10V, ID =1A, RG=6Ω)	td(on)	-	20.5	ns
Rise Time		tr	-	39.7	
Turn-Off Delay Time		td(off)	-	689	
Fall Time		tf	-	191	
Gate-Resistance (VGS = 0V, VDS=0V,f=1MHz)	Rg	-	2129	-	Ω

Note 2: Pulse test; pulse width ≤ 300μs, duty cycle ≤ 2%

7. ELECTRICAL CHARACTERISTICS CURVES

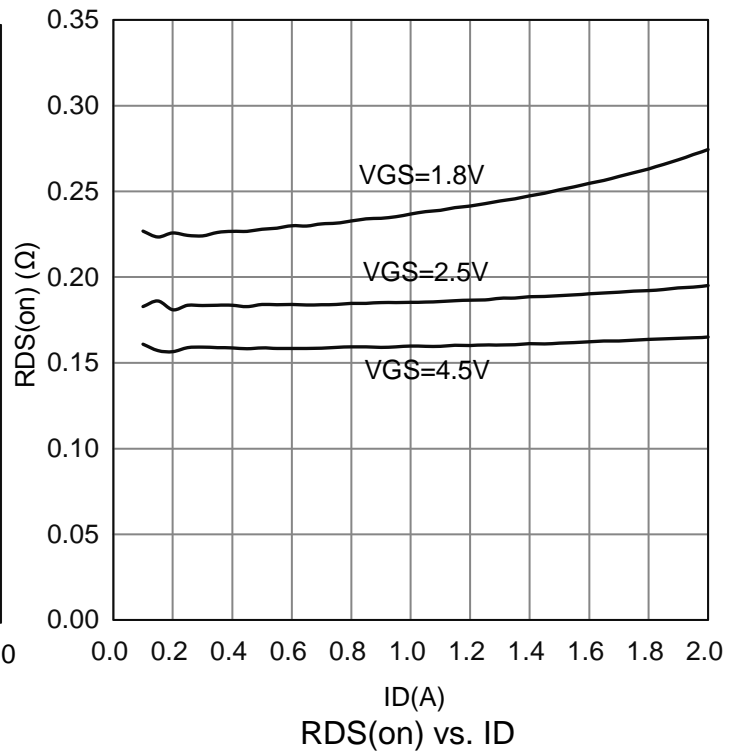
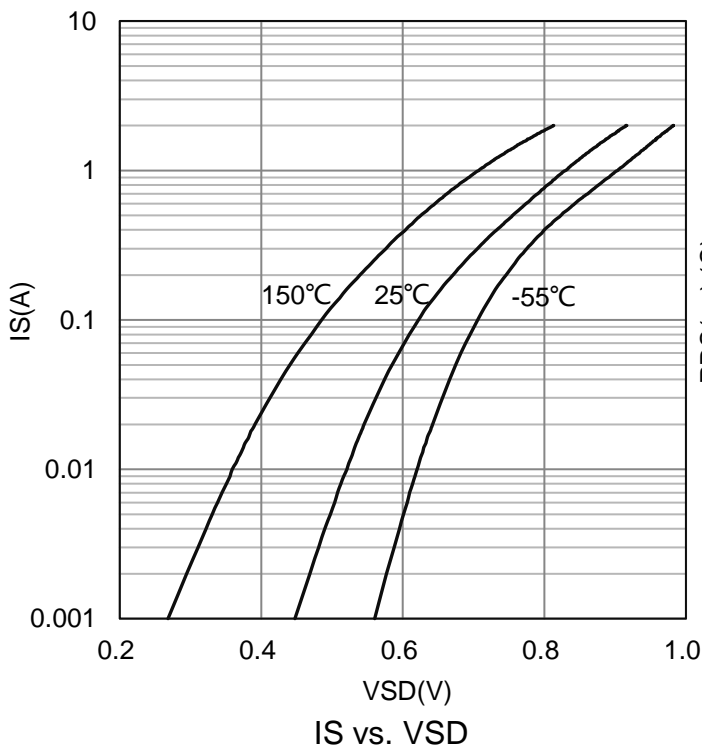
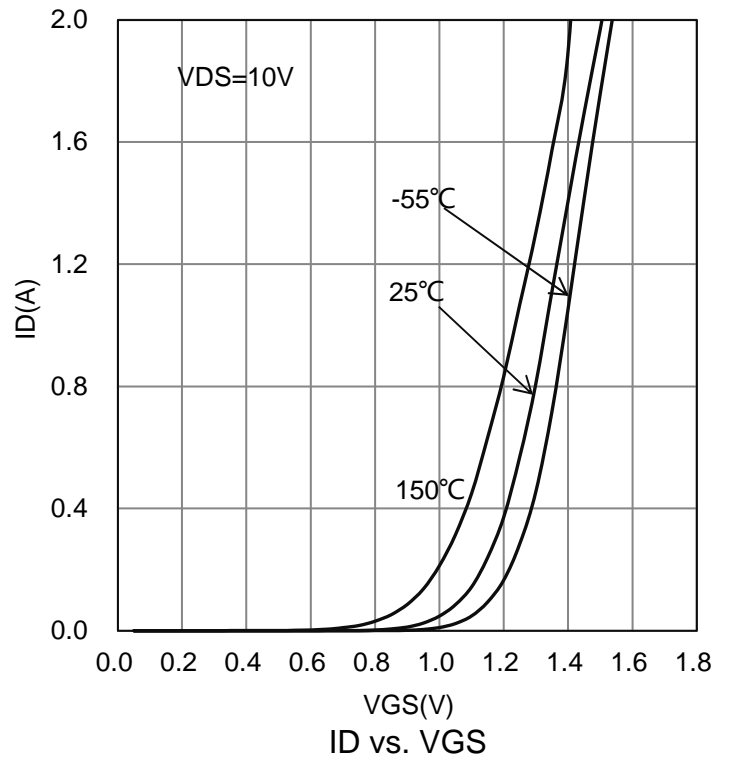
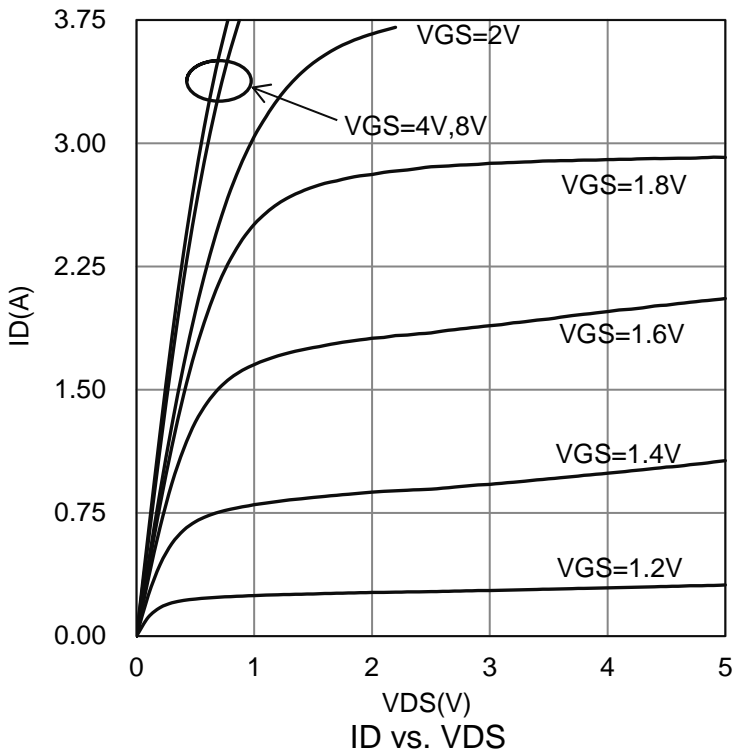

7. ELECTRICAL CHARACTERISTICS CURVES (Con.)

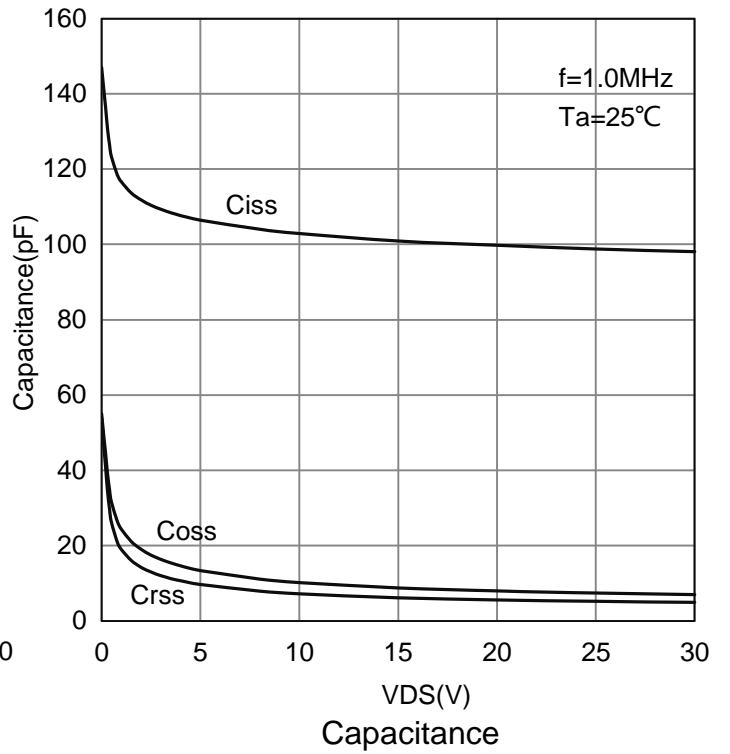
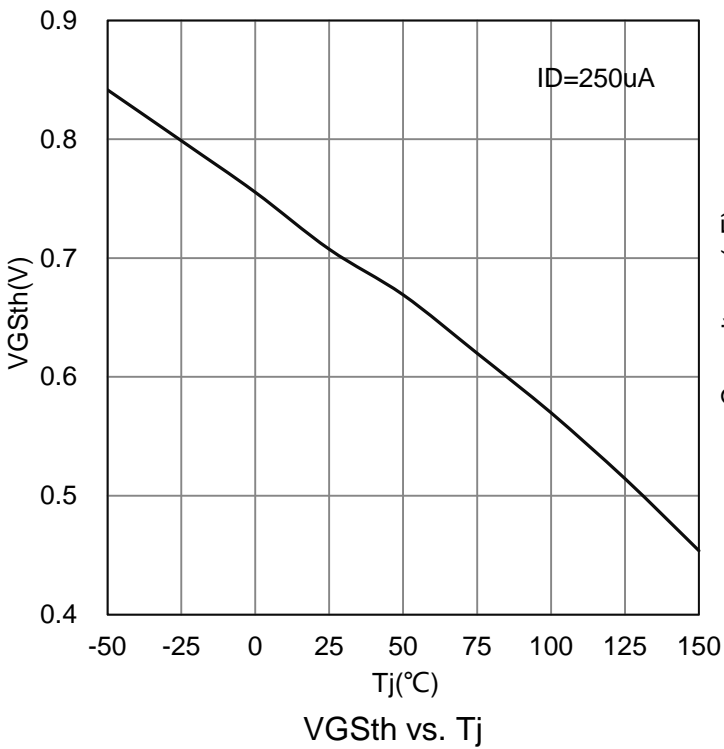
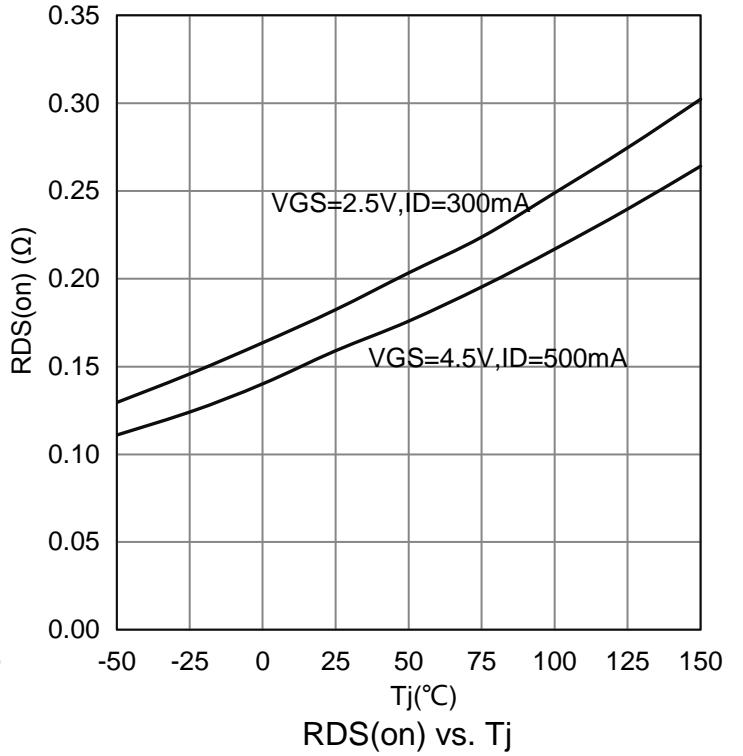
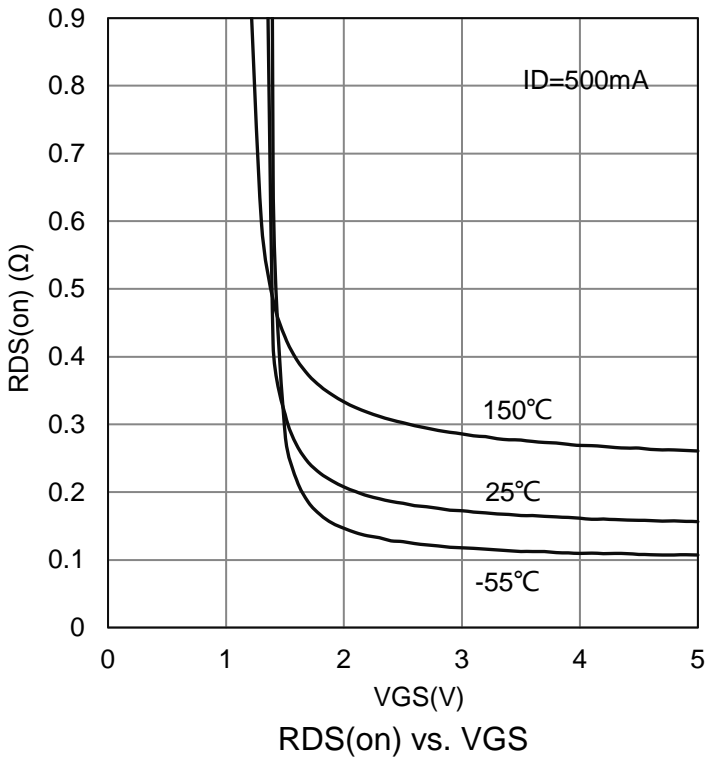

8. OUTLINE AND DIMENSIONS

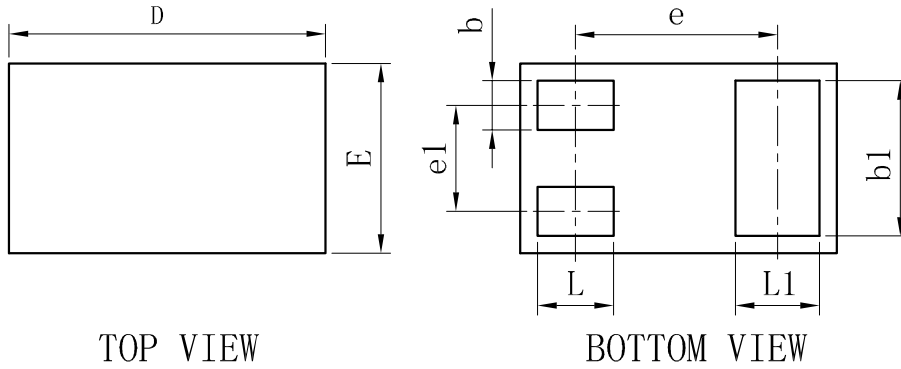

SOT883			
Dim	Min	Typ	Max
D	0.95	1.00	1.05
E	0.55	0.60	0.65
e	-	0.64	-
e1	-	0.34	-
L	0.19	0.24	0.29
L1	0.22	0.27	0.32
b	0.10	0.15	0.20
b1	0.44	0.49	0.54
A	0.43	0.48	0.53
A1	0	-	0.05
All Dimensions in mm			

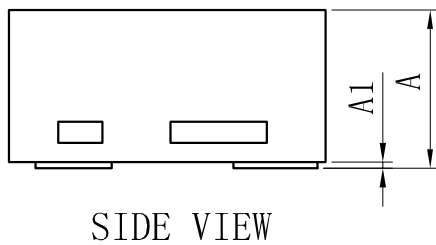

9. SOLDERING FOOTPRINT

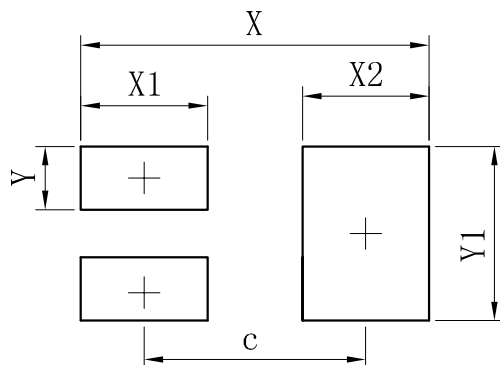

Dimensions	(mm)
c	0.70
X	1.10
X1	0.40
X2	0.40
Y	0.20
Y1	0.55

DISCLAIMER

- Before you use our Products, you are requested to carefully read this document and fully understand its contents. LRC shall not be in any way responsible or liable for failure, malfunction or accident arising from the use of any LRC's Products against warning, caution or note contained in this document.
- All information contained in this document is current as of the issuing date and subject to change without any prior notice. Before purchasing or using LRC's Products, please confirm the latest information with a LRC sales representative.