

# LN2306EFLT1G

N-Channel 30V(D-S) MOSFET

## 1. FEATURES

- VDS= 30V
- RDS(ON) ≤ 75mΩ@ VGS =4.5V
- RDS(ON) ≤ 100mΩ@ VGS=2.5V
- We declare that the material of product compliance with RoHS requirements and Halogen Free.
- ESD Protected

## 2. APPLICATIONS

- Power Management in Note book
- Portable Equipment
- Battery Powered System
- Load Switch

## 3. DEVICE MARKING AND ORDERING INFORMATION

Device	Marking	Shipping
LN2306EFLT1G	2EF	3000/Tape&Reel

## 4. MAXIMUM RATINGS(Ta = 25°C)

Parameter	Symbol	Limits	Unit
Drain–Source Voltage	VDSS	30	V
Gate–to–Source Voltage – Continuous	VGS	± 12	V
Drain Current	ID	3.5	A
Pulsed Drain Current (Note 2)	IDM	14	
Drain Current(Note 3)	ID	1.7	A
Pulsed Drain Current (Note 3)	IDM	6.8	

## 5. THERMAL CHARACTERISTICS

Parameter	Symbol	Limits	Unit
Maximum Power Dissipation	PD	0.89	W
Maximum Power Dissipation(Note 3)	PD	0.4	W
Thermal Resistance, Junction–to–Ambient(Note 1)	RθJA	140	°C/W
Junction–to–Ambient(Note 3)	RθJA	304	
Junction and Storage temperature	TJ,Tstg	-55~+150	°C

1.1-in2 2oz Cu PCB board.

2.Pulse width limited by maximum junction temperature.

3.Surface mounted on FR4 board using the minimum recommended pad size.

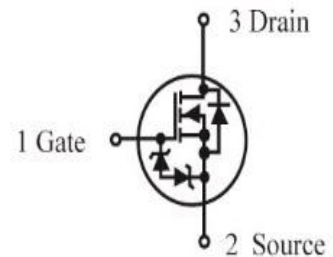
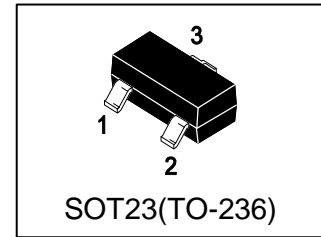

**6. ELECTRICAL CHARACTERISTICS (Ta= 25°C)**

Characteristic	Symbol	Min.	Typ.	Max.	Unit	
<b>Static</b>						
Drain–Source Breakdown Voltage (VGS = 0 V, ID = 250 μA)	V(BR)DSS	30	-	-	V	
Zero Gate Voltage Drain Current (VDS= 30 V, VGS= 0 V)	IDSS	-	-	1	μA	
Gate–Body Leakage Current, Forward (VDS = 0 V, VGS = 10 V)	IGSSF	-	-	10	μA	
Gate–Body Leakage Current, Reverse (VDS = 0 V, VGS = -10 V)	IGSSR	-	-	-10	μA	
Gate Threshold Voltage (VDS = VGS, ID = 250 μA)	VGS(th)	0.6	-	1.4	V	
Static Drain–Source On–State Resistance(Note 4) (VGS = 4.5 V, ID =2.7 A) (VGS = 2.5 V, ID = 1 A)	RDS(on)	-	54 75	75 100	mΩ	
<b>Dynamic</b>						
Input Capacitance (VGS = 0 V, f = 1.0MHz, VDS= 10 V)	Ciss	-	247	-	pF	
Output Capacitance (VGS = 0 V, f = 1.0MHz, VDS= 10 V)	Coss	-	33	-	pF	
Reverse Transfer Capacitance (VGS = 0 V, f = 1.0MHz, VDS= 10 V)	Crss	-	5	-	pF	
Total Gate Charge	(VGS = 4.5 V, ID= 1 A, VDS= 10 V)	Qg	-	4.7	-	nC
Threshold Gate Charge		Qg	-	3.6	-	
Gate–Source Charge		Qgs	-	1.9	-	
Gate–Drain Charge		Qgd	-	1.6	-	
Turn-On Delay Time	(VDD = 10 V, VGS = 4.5 V, ID = 1 A, RG = 6Ω)	td(on)	-	12	-	ns
Rise Time		tr	-	19	-	
Turn-Off Delay Time		td(off)	-	60	-	
Fall Time		tf	-	27	-	
Forward Voltage (VGS = 0 V, IS = 2 A)	VSD	-	0.8	1.2	V	

4.Pulse Test: Pulse Width ≤300 μs, Duty Cycle ≤2.0%.

**7. ELECTRICAL CHARACTERISTICS CURVES**

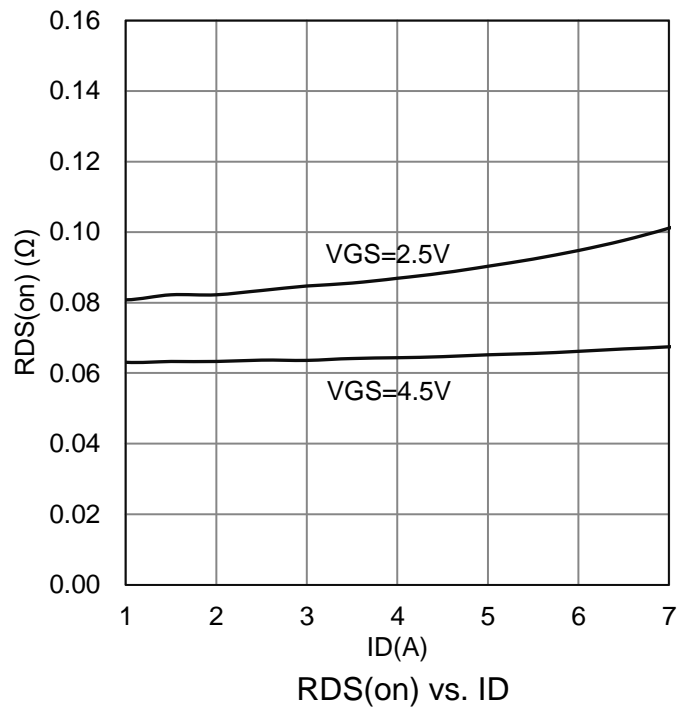
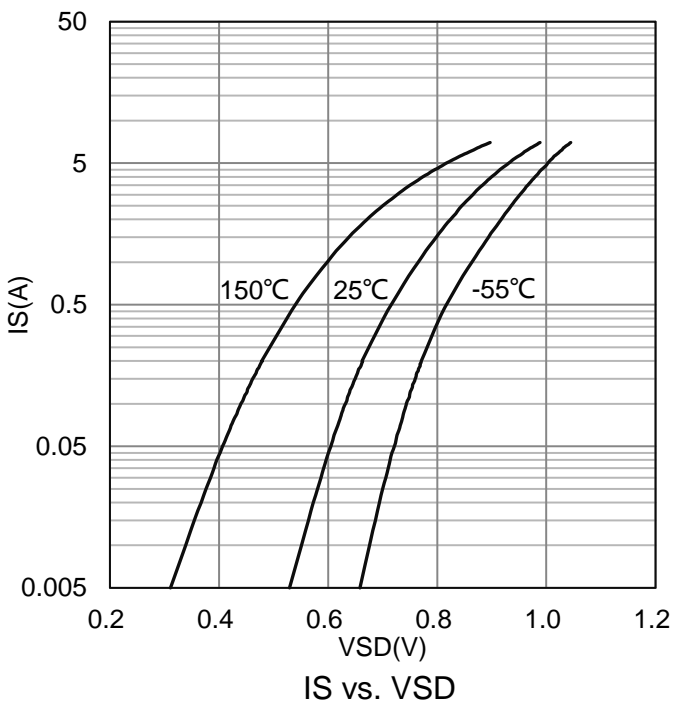
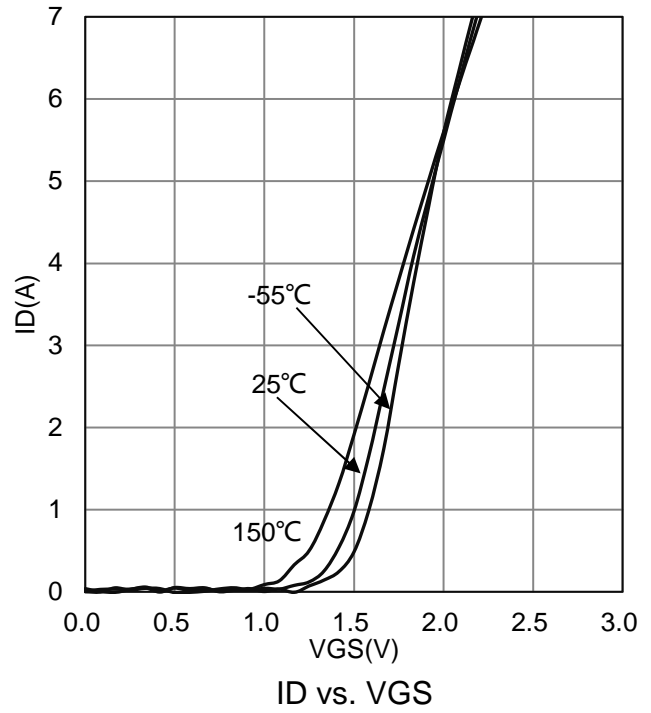
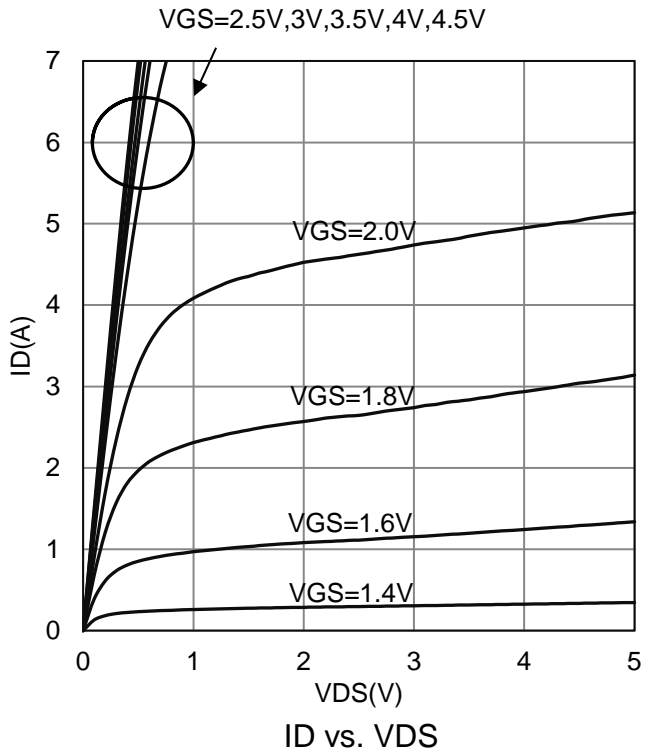

### 7. ELECTRICAL CHARACTERISTICS CURVES(Con.)

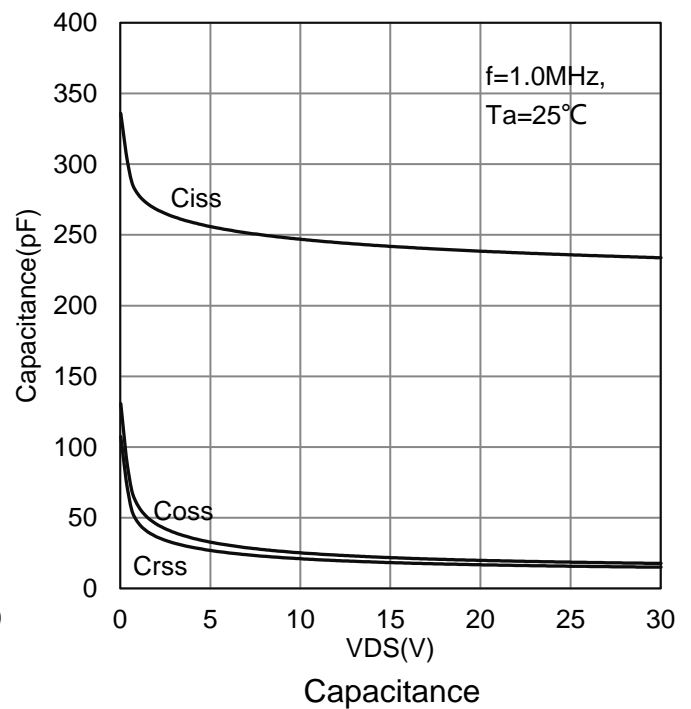
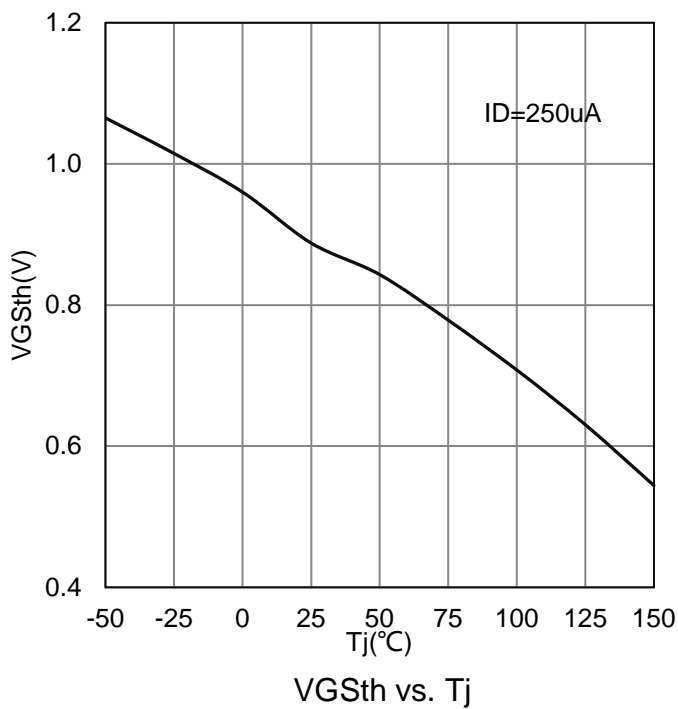
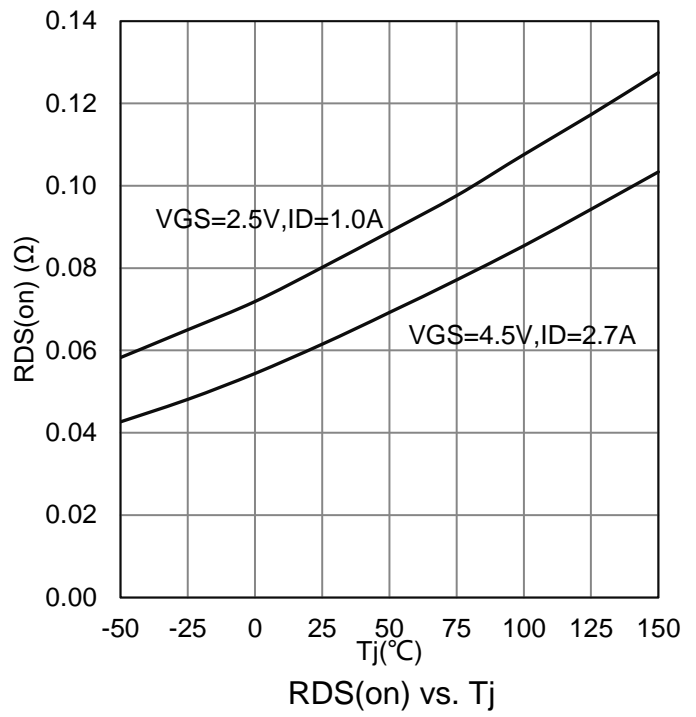
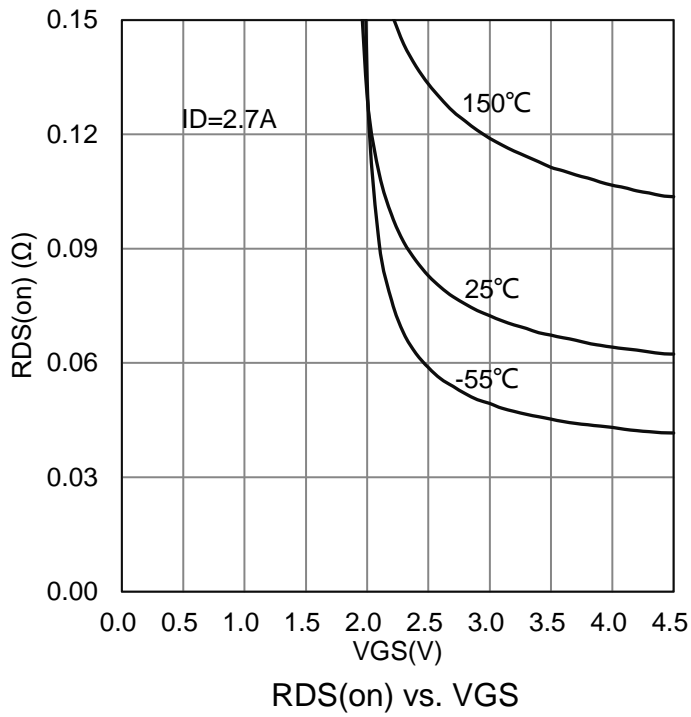

**7. ELECTRICAL CHARACTERISTICS CURVES(Con.)**

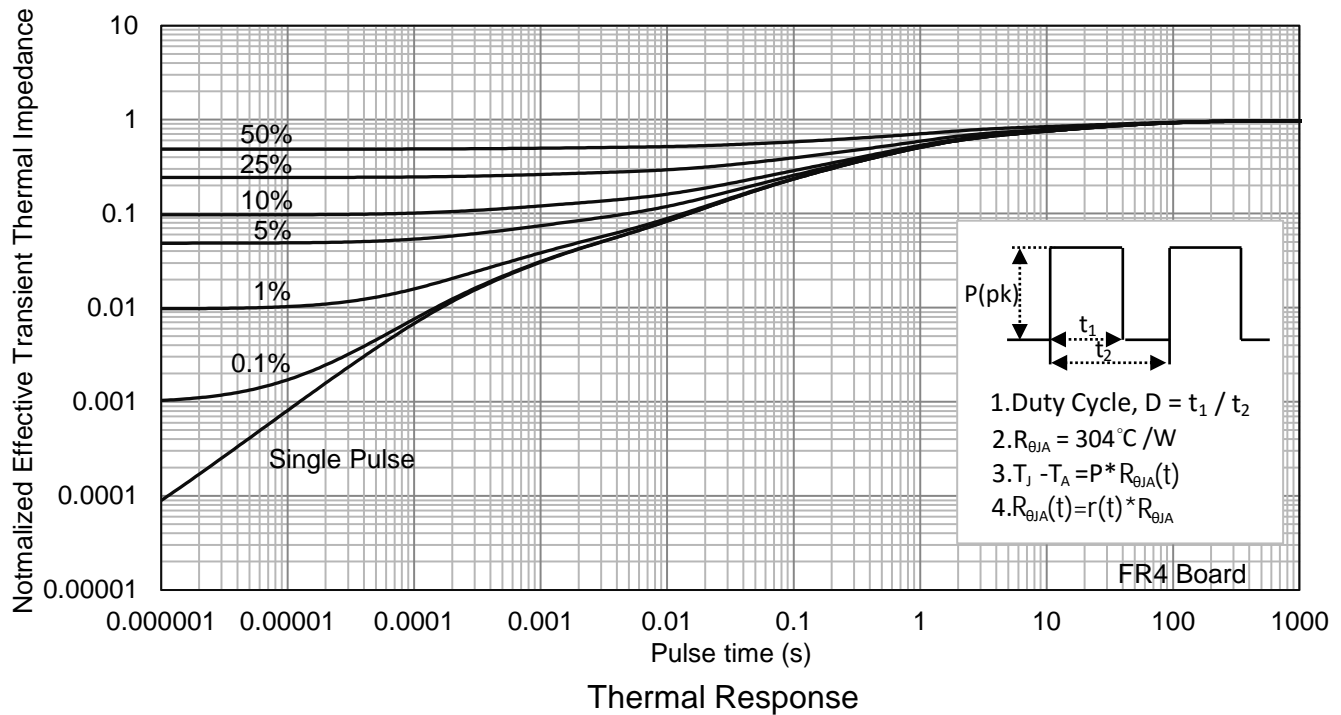
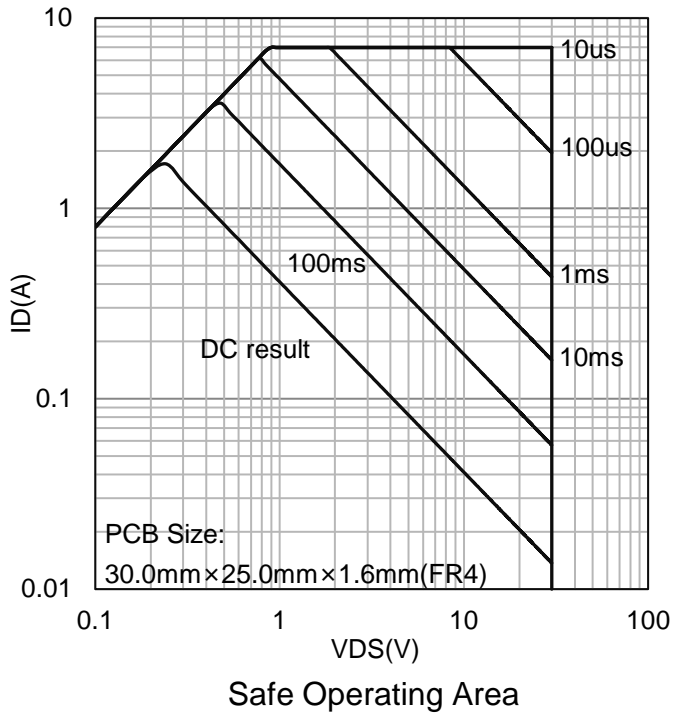

### 8. OUTLINE AND DIMENSIONS

#### SOT23E

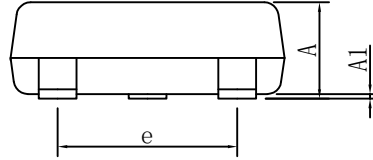
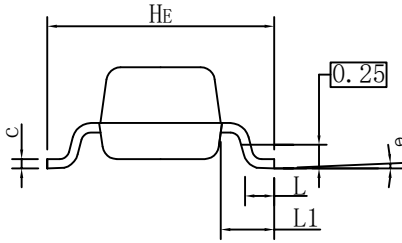

SOT23E			
DIM	MIN	NOR	MAX
A	0.90	1.00	1.10
A1	0.01	0.06	0.10
b	0.30	0.40	0.50
c	0.10	0.17	0.20
D	2.80	2.90	3.00
E	1.20	1.30	1.40
e	1.80	1.90	2.00
L	0.20	0.40	0.60
L1	0.60REF		
HE	2.20	2.40	2.60
θ	0°	-	10°
All Dimensions in mm			

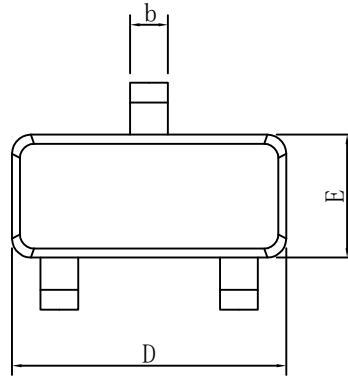

#### GENERAL NOTES

1. Top package surface finish Ra0.4±0.2um
2. Bottom package surface finish Ra0.7±0.2um
3. Side package surface finish Ra0.4±0.2um

### 9. SOLDERING FOOTPRINT

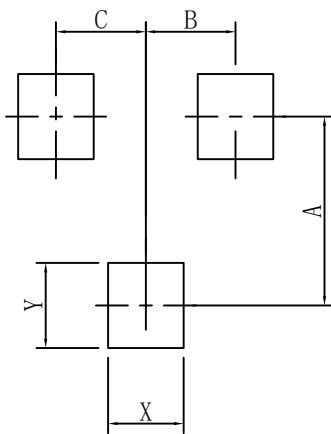

SOT23E	
DIM	(mm)
X	0.80
Y	0.90
A	2.00
B	0.95
C	0.95

## **DISCLAIMER**

- Curve guarantee in the specification. The curve of test items with electric parameter is used as quality guarantee. The curve of test items without electric parameter is used as reference only.
- Before you use our Products for new Project, you are requested to carefully read this document and fully understand its contents. LRC shall not be in any way responsible or liable for failure, malfunction or accident arising from the use of any LRC's Products against warning, caution or note contained in this document.
- All information contained in this document is current as of the issuing date and subject to change without any prior notice. Before purchasing or using LRC's Products, please confirm the latest information with a LRC sales representative.