

Description

PESD0542U005 polymeric ESD suppressor help protect sensitive electronic equipment against electrostatic discharge (ESD) without distorting data signals. This protection is a result of its ultra-low capacitance of only 0.05 pF (I/O to GND), and it can be used to help equipment to pass IEC61000-4-2 level 4 test (15KV air, 8KV contact discharge).

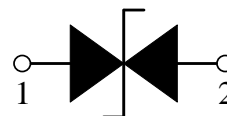
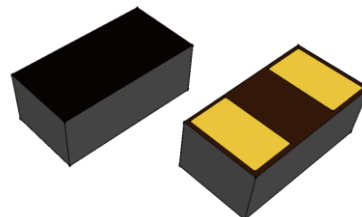

Features

- The best ESD protection for high speed, low voltage applications
- RoHS compliant and halogen free
- Ultra low capacitance, 0.05 pF (typ.)
- Low leakage current (<10nA)
- Fast response time (<1ns)
- Bi-directional, single line protection
- Surface mount
- MSL 1

Materials Information

RoHS Compliant

Halogen Free

RoHS



Applications

- Smart Phone/Mobile Internet Device
- Laptop/Desktop Computer
- Antennas (Cell Phones, GPS...)
- High Speed Ethernet
- USB 2.0 and USB 3.0
- Lightning and Thunder Bolt Interface

Caution: This component is designed for signal line protection only, not intended to be used on power lines or for power bus applications.

General Characteristics

Parameter	Value	Unit
Contact Discharge Voltage Per IEC61000-4-2	8K	V
Air Discharge Voltage Per IEC61000-4-2	15K	V
Operating Temperature	-55 to +125	°C
Storage Temperature	-40 to +85	°C

Electrical Characteristics (T_A =25°C)

Parameter	Symbol	Test Conditions	Min.	Typ.	Max.	Units
Continuous Operating Voltage	V _{DC}	---	---	---	5	V
Trigger Voltage	V _T	IEC61000-4-2 8KV contact discharge	---	450	---	V
Clamping Voltage	V _C	IEC61000-4-2 8KV contact discharge	---	40	---	V
Leakage Current	I _L	DC 5V shall be applied on component	---	---	10	nA
Capacitance	C _P	Measured at 10MHz	---	0.05	---	pF
ESD Pulse Withstand	Pulses	IEC61000-4-2 8KV contact discharge	1000	---	---	---

Notes:

Trigger and clamping voltage are measured per IEC 61000-4-2, 8KV contact discharge method.

Environmental Specifications

	Solder Heat	Solderability	Preconditioning	Thermal Shock	Bias Humidity Test
Test Conditions	1. 150°C, 4H; 2. 260°C, 10s, 1 Times	245°C, 5s	1. 125°C, 24H; 2. 85°C, 85%RH, 162H; 3. 260°C Reflow, 3 Times	-55°C—125°C, 30min dwell, 1000cycles	85°C, 85%RH, V _{DC} , 1000H
Pass/Fail Criteria	90% Coverage	95% Coverage	I _L ≤10nA	I _L ≤10nA	I _L ≤10nA

	Bias Heat Test	Bias Low Temp Test	Vibration	Mechanical Shock	Solvent Resistance
Test Conditions	125°C, V _{DC} , 1000H	-55°C, V _{DC} , 1000H	10Hz-50Hz-10HZ, 2hrs each in X-Y-Z axis	1500G, 0.5ms, X-Y-Z axis 3 times	IPA, ultrasonic 300s
Pass/Fail Criteria	I _L ≤10nA	I _L ≤10nA	No Physical Damage I _L ≤10nA	No Physical Damage I _L ≤10nA	No Physical Damage I _L ≤10nA

Typical ESD Response (IEC 61000-4-2, 8KV contact discharge)

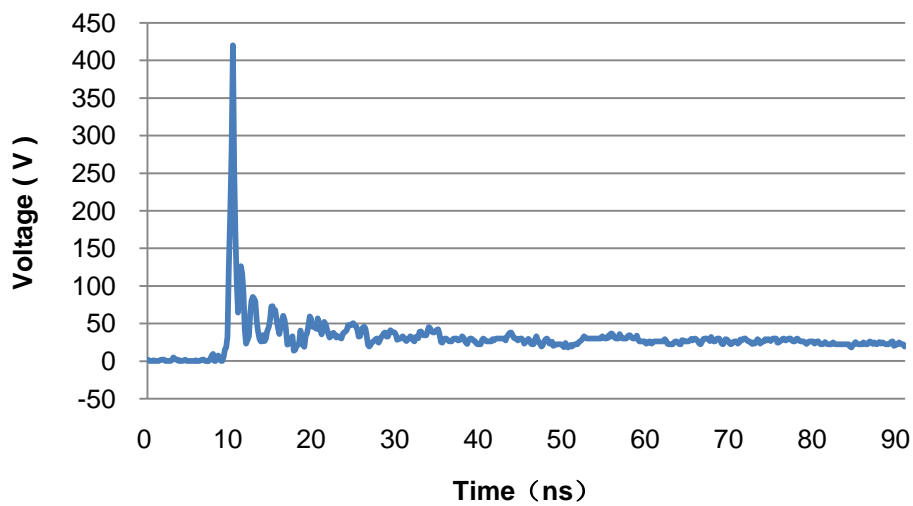
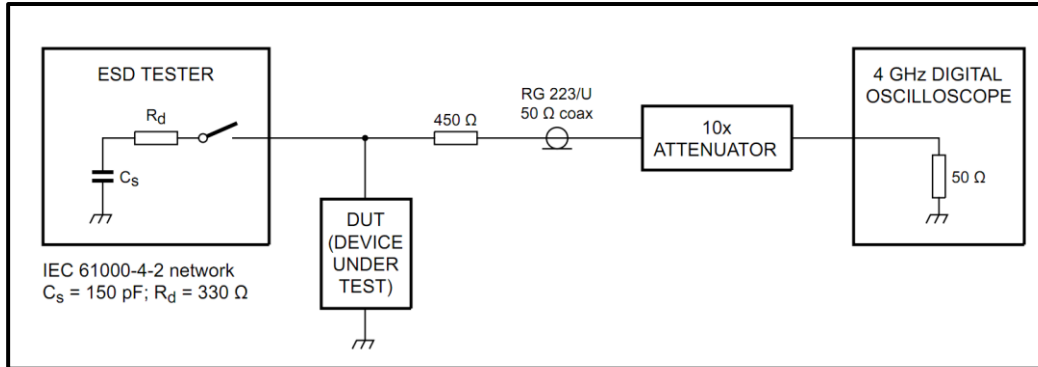

Typical Device Capacitance VS. Frequency

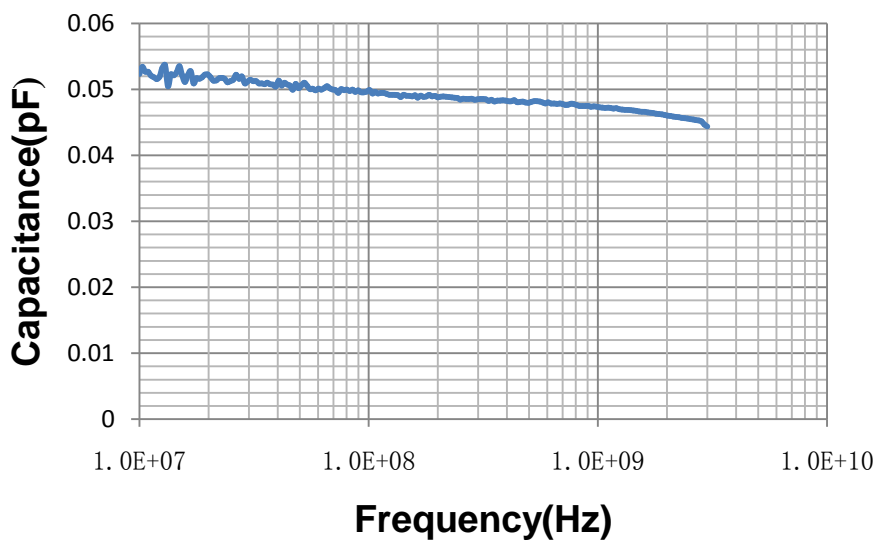

Eye Diagram Measurement

HDMI Mask at 3.4 Gbps

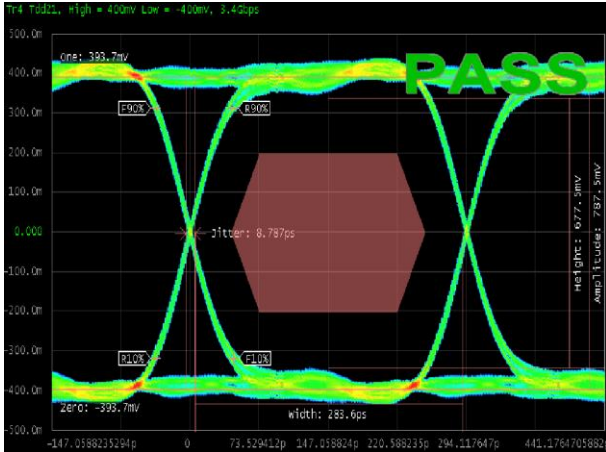

USB3.0 Mask at 5.0 Gbps

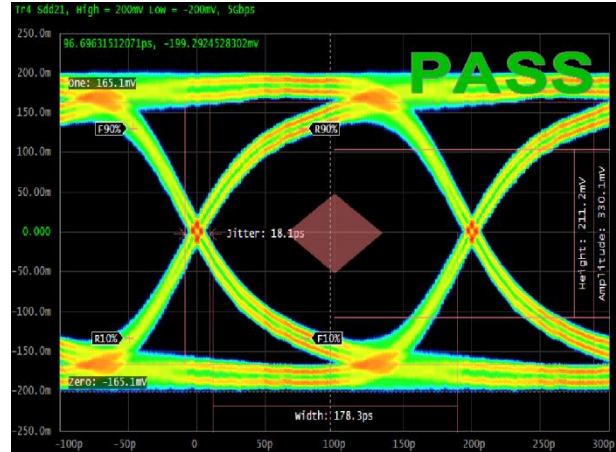

ESD Protection for Signal Line

The PESD is designed for the protection of one bidirectional data line from ESD damage.

- Place the PESD as close to the input terminal or connector as possible.
- Minimize the path length between the PESD and the protected signal line.
- Use ground planes whenever possible.

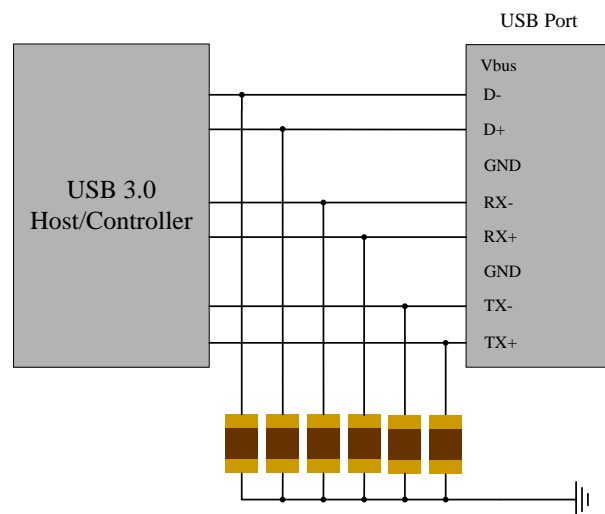
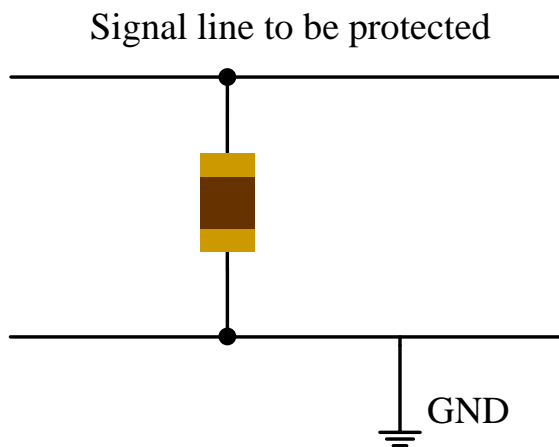

Package Dimension

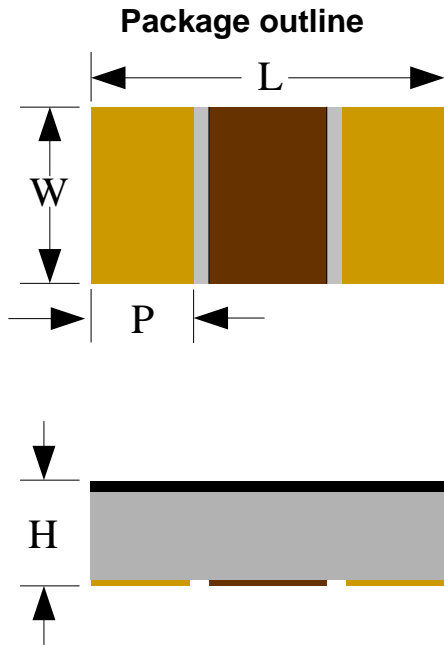

Recommended Solder Pad Footprint

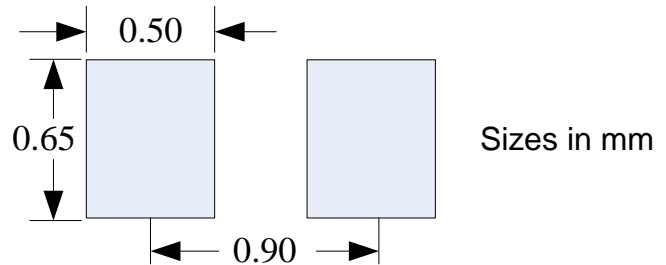

Dimension	Unit: Millimeters		
	Min.	Typ.	Max.
L	0.90	1.00	1.10
W	0.42	0.52	0.62
P	0.15	0.25	0.35
H	0.25	0.38	0.45

Taping Specification

1. Tape Dimension Unit: Millimeters

Packaging

10,000 pieces in paper tape on 7" (178mm) reel

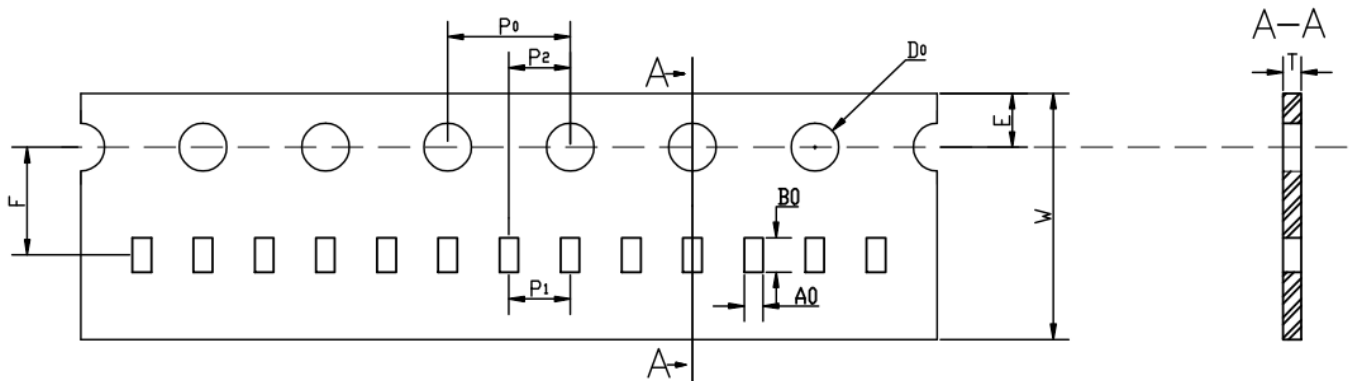

A ₀	B ₀	W	F	E	P ₁	P ₂	P ₀	D ₀	T
0.68±0.03	1.17±0.03	8.00±0.10	3.50±0.05	1.75±0.10	2.00±0.05	2.00±0.05	4.00±0.10	1.55±0.05	0.43±0.03

2. Reel Dimension
Unit: Millimeters

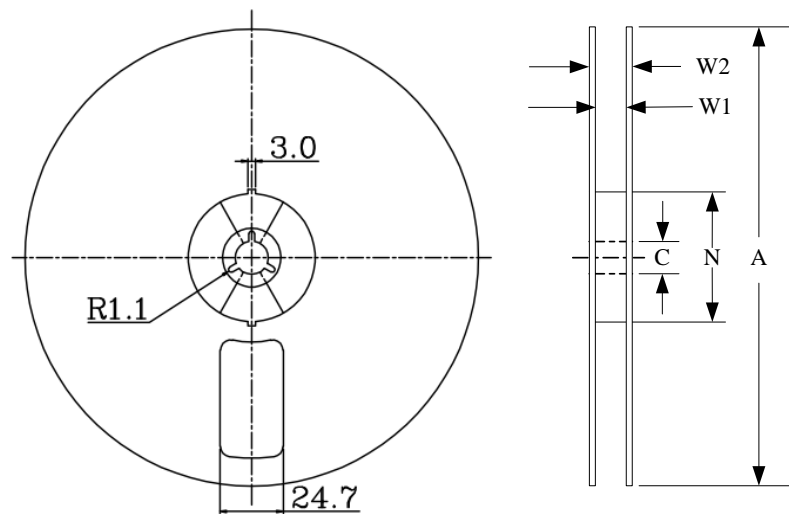

A	N Min.	C	W2 Max.	W1 Min.	W1 Max.
178.0 ±2.0	50.0	13.0±0.2	14.4	8.4	9.9

Soldering Parameters

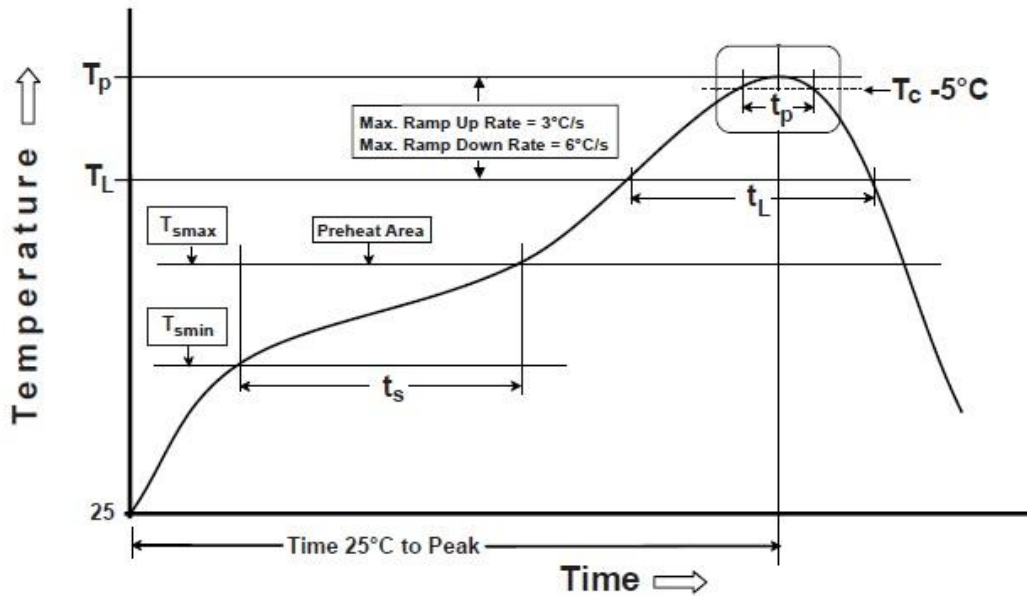

Profile Feature	Pb-Free Assembly
Pre Heat	
Temperature Min (T_{smin})	150 °C
Temperature Max (T_{smax})	200 °C
Time (t_s) from (T_{smin} to T_{smax})	60-120 seconds
Ramp-up Rate (T_L to T_p)	3 °C/second max.
Liquidus temperature (T_L)	217 °C
Time (t_L) maintained above T_L	60-150 seconds
Peak package body temperature (T_p)	260 ^{+0/-5} °C
Time (t_p)* within 5 °C of the specified classification temperature (T_c)	30* seconds
Ramp-down Rate (T_p to T_L)	6 °C/second max.
Time 25 °C to peak temperature	8 minutes max.
* Tolerance for peak profile temperature (T_p) is defined as a supplier minimum and a user maximum.	