

7	8	9
标记 MARK	ECN编号/变更内容 ECN NO/DEFINITION	修改 REVISE
		日期 DATE
		核准 APPROVE

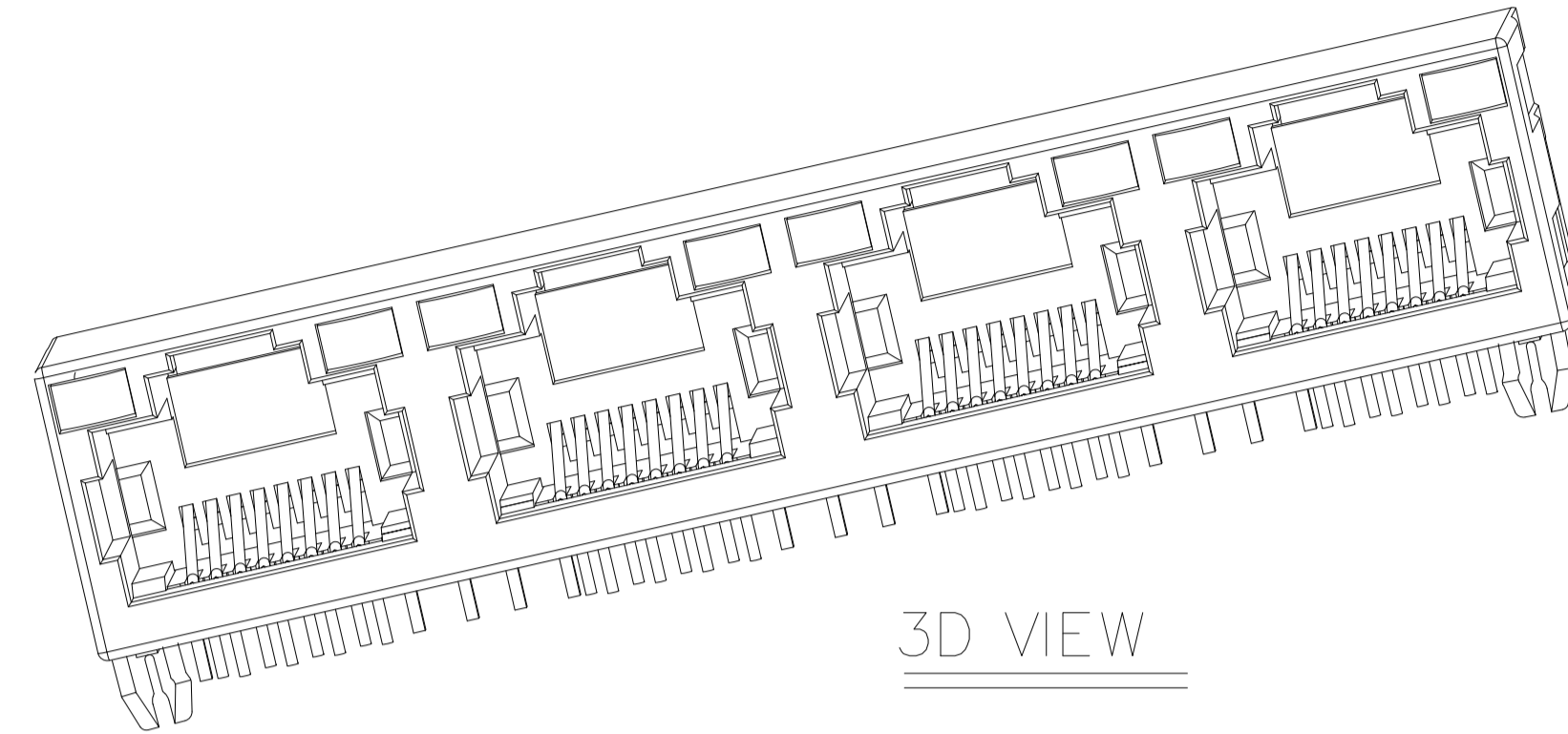
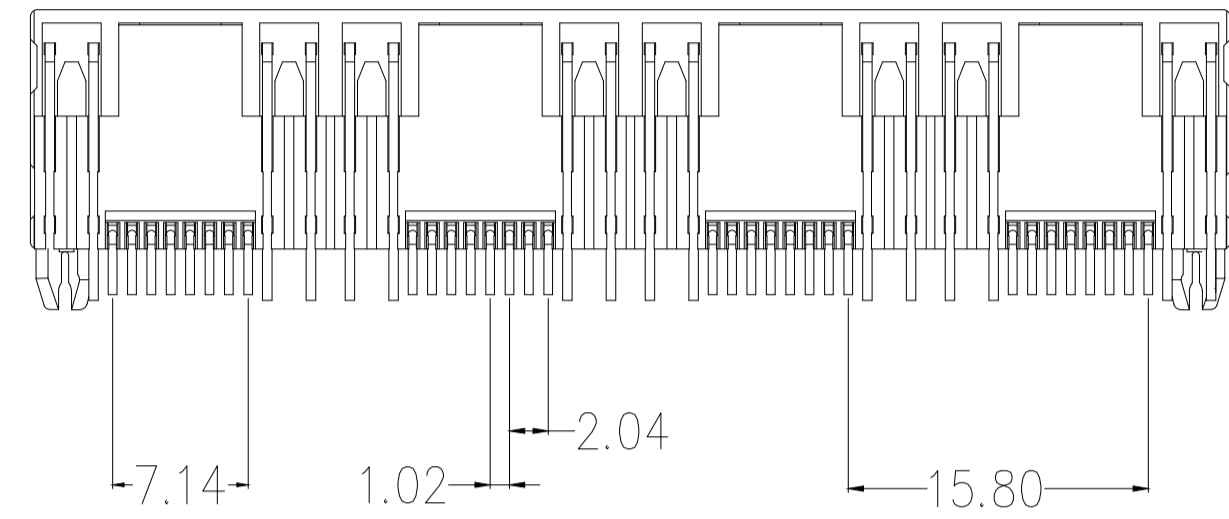

NOTES:

- MATERIAL:
 - HOUSING: PBT ,COLOR IS BLACK;
 - CONTACT: PHOSPHOR BRONZE, $\phi 0.46 \pm 0.02\text{mm}$;
- FINISH: PLATED GOLD OVER NI;
- RECINNEBDED PCB THICKNESS: 1.60mm;
- ELECTRICAL:
 - VOLTAGE RATING: 125 VAC RMS;
 - CURRENT RATING: 1.5 AMP;
 - CONTACT RESISTANCE: 35MILLIOHMS MAX.;
 - WITHSTAND VOLTAGE: 500 VAC RMS 50(60)Hz,1MIN.;
 - INSULATION RESISTANCE: 500MEGOHMS MIN @500V DC;
- MECHANICAL:
 - MATING/UNMATING FORCE: 25N MAX.;
 - RETENTIION STRENGTH: 50N MIN.;
 - OPERATING LIFE: 750 CYCLES MIN.;
- SALT SPRAY TEST: 12H;
- SOLDERABILITY: $245 \pm 5^\circ\text{C}, 5 \pm 0.5\text{S}$;
- RESISTANCE TO SOLDER: $260 \pm 5^\circ\text{C}, 10 \pm 1\text{S}$;
- ENVIRONMENTAL:
 - STORAGE TEMPERATURE RANGE: $-40^\circ\text{C} \sim +85^\circ\text{C}$;
 - OPERATION TEMPERATURE RANGE: $-25^\circ\text{C} \sim +70^\circ\text{C}$;
- MATES WITH: MODULAR PLUGS THAT CONFORM TO FCC REGULATION PART 68.500;

3D VIEW

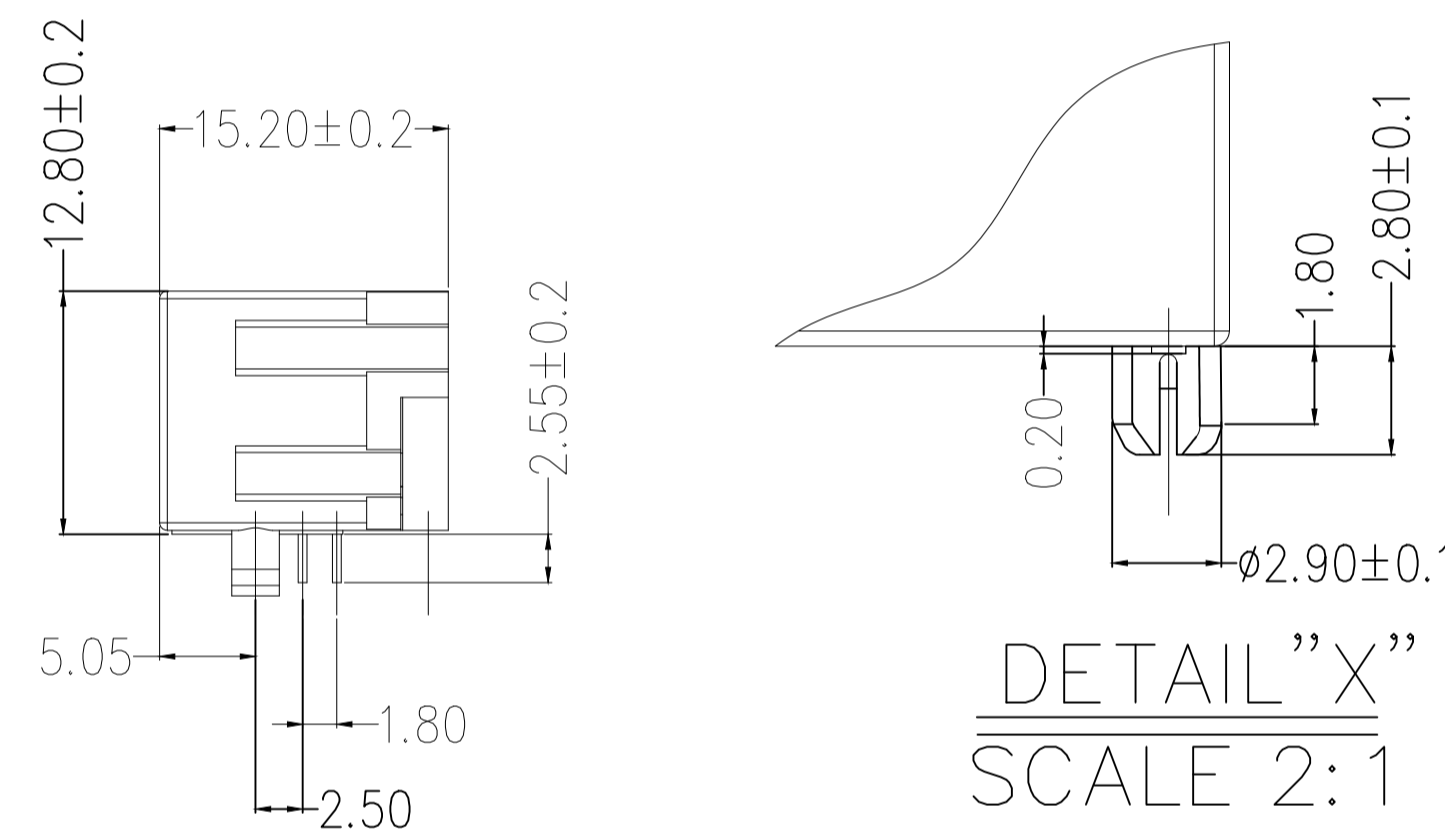
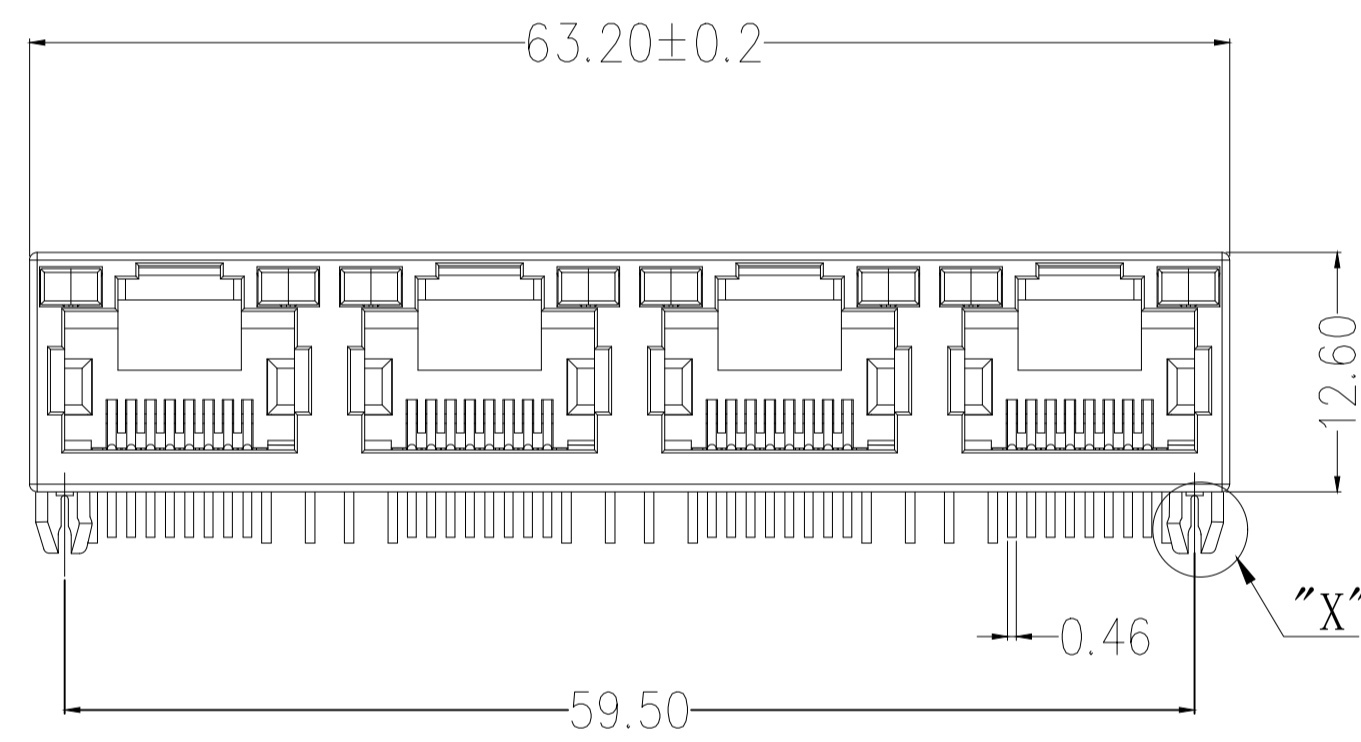

DETAIL "X"
SCALE 2:1

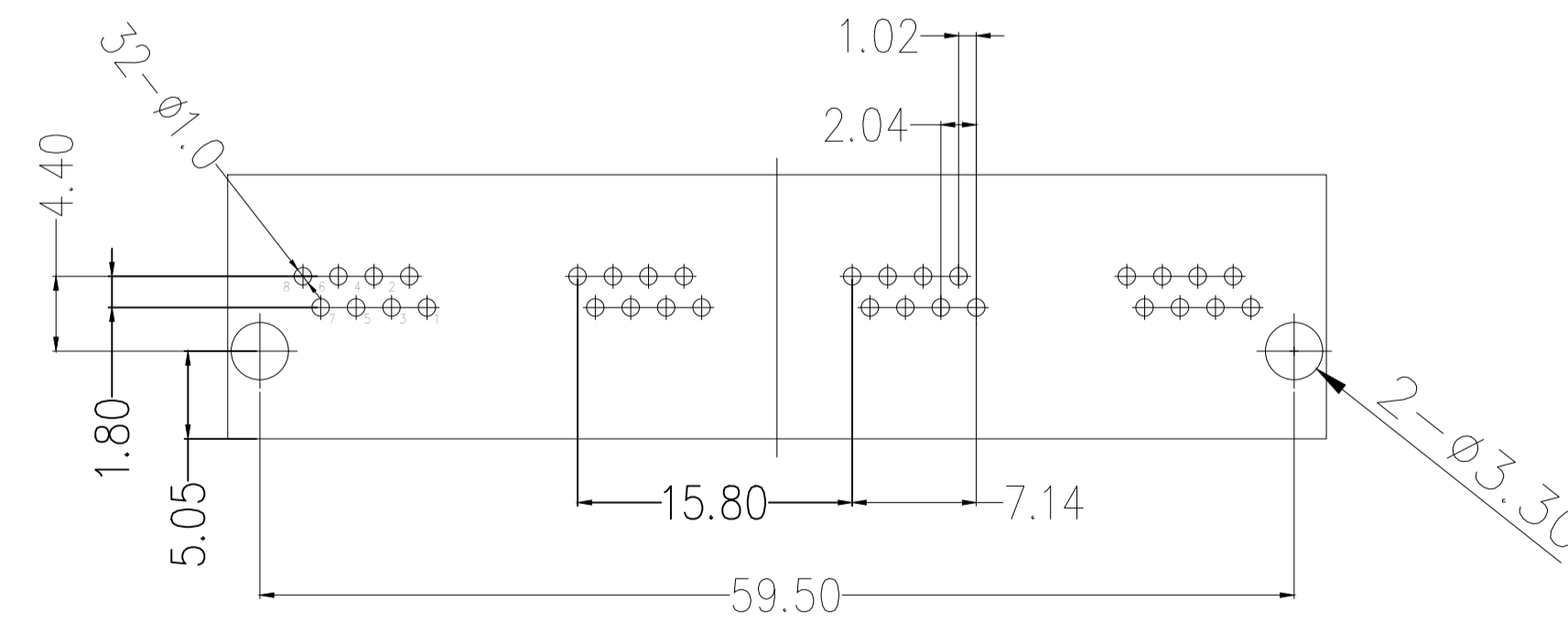
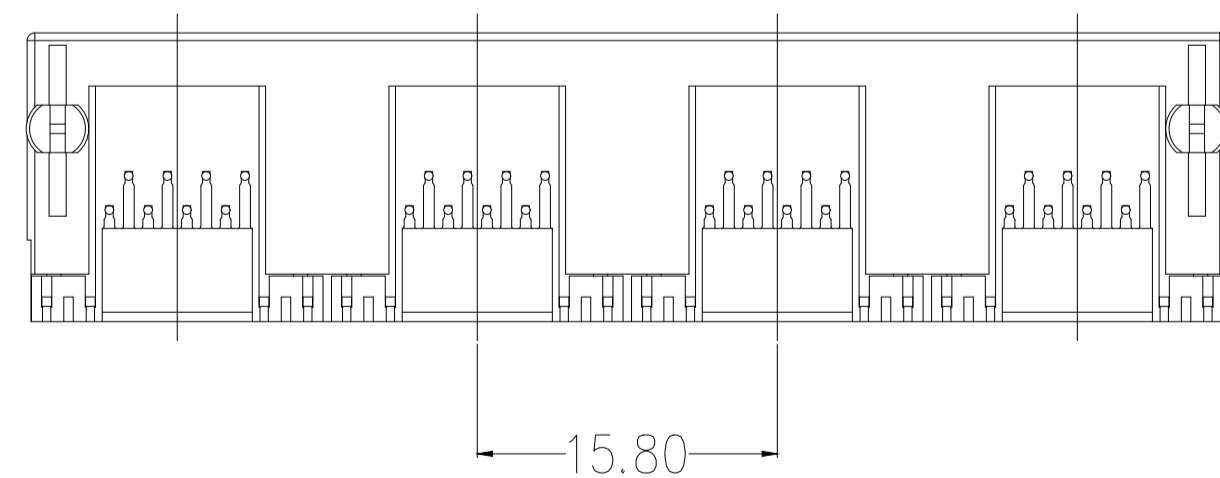

RECOMMENDER P.C.B.LAYOUT TOP VIEW
(COMPONENT SIDE TOLERANCE ± 0.05)

2	接触	铜	镀金G/F	
1	基座	PBT	黑色	
序号	品名	材质	电镀/颜色	备注



深圳市虹成电子有限公司

品名 TITLE	网口
料号 PART NO	HC-WK88-H16-1X4-QS

UNLESS GENERAL TOLERANCE:	OTHERWISE, TOLERANCE:	比列 SCALE	1:1		
X. xxx ± 0.10	X. xx ± 0.20	单位 UNIT	MM	制图 DRAW	AhYe
X. x ± 0.30		张数 PART NO	1 OF 1	审核 CHECKED	夏操云
ANGULAR:		版本 REV	A	批准 APPROVE	赵亮亮
X. xx° $\pm 1^\circ$	X. x° $\pm 3^\circ$				
X. ° $\pm 5^\circ$					

