

REV.	DESCRIPTION	NAME	DATE
A	NEW ISSUE		

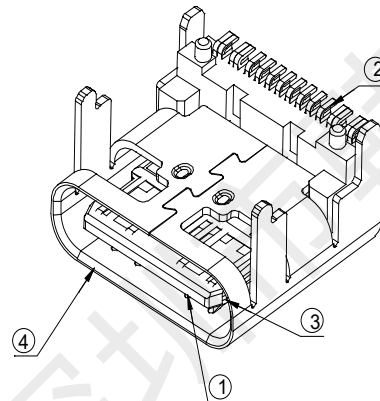
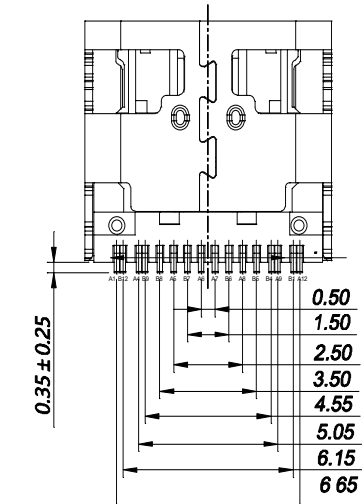
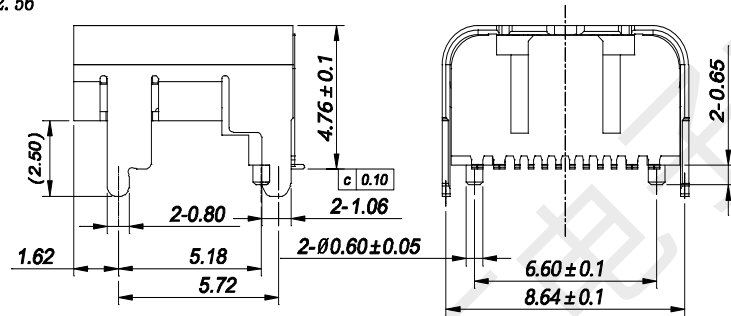
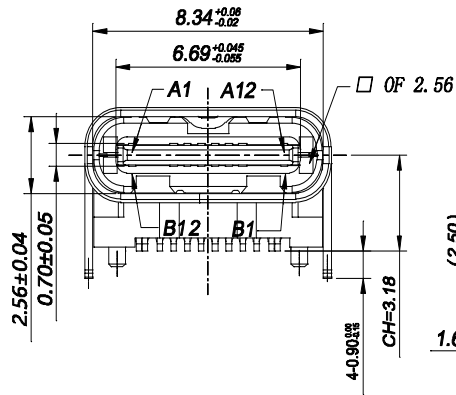
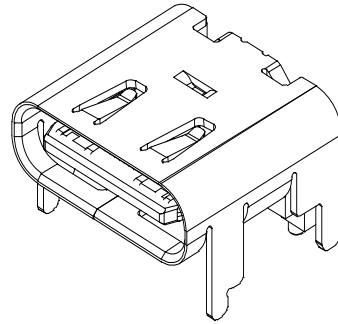
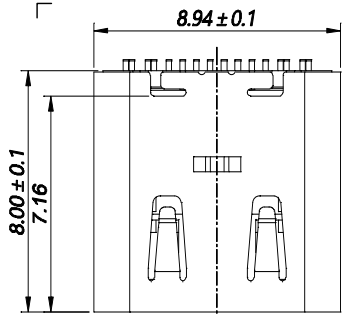

规格说明 Specifications:

1. 电气特性 Electrical:

额定电压(Rated voltage): 20V DC

额定电流(Rated current): 5A VBUS引脚;

1.25A用于GND引脚, 其他引脚为0.25A.

接触电阻(Contact resistance): 40mΩ Max

测试条件: 20mv, 100mA下测量.

绝缘电阻(Insulation resistance): 100MΩ Min

耐电压(Withstand Voltage): 100V AC

2. 机械性能 Mechanical:

插入力(Mate force): 0.5-2.0Kg

拔出力(Unmate force): 0.6-2.0Kg

插拔次数(Durability): 10000 Cycles.

3. 材料 Material:

胶芯(Housing): LCP UL94 V-0

端子(Contact): C2680, T=0.2mm; 镍底, 镀金

外壳(Shell): 不锈钢201-H 表面镀镍

4. 温度范围(Temperature Range): -30°C to +80°C.

TOLERANCE UNSPECIFIED

.0	±0.35
.00	±0.25
.000	±0.15
X°	±2.00°

CUSTOMER DRAWING



深圳市韩下电子有限公司

TITLE:

HX TYPE-C 16P+1.6

DRAWN
DATE

黄彬 2020.6.17

SIZE:A4

UNIT:mm.

PART. NO: UC06-5161X-20BR

CHECKED
DATE

张伟 2020.6.17

SCALE: 1:1

PROJECTION

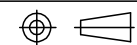

REV.: A

APPROVED
DATE

罗小春 2020.6.17

DWG PATH

C00-0000-0074

PATH 1/3