

PART NUMBER	LENS COLOR	LED COLOR	WIRE COLOR	OPERATING VOLTAGE	"L"
658-2506-103F	RED DIFF.	RED	BLACK	8-60VDC	6.0 [152,4] ±.13 [3,3]
			RED		
658-2606-103F	GREEN DIFF.	GREEN	BLACK	8-60VDC	6.0 [152,4] ±.13 [3,3]
			GREEN		
658-2706-103F	YELLOW DIFF.	YELLOW	BLACK	8-60VDC	6.0 [152,4] ±.13 [3,3]
			YELLOW		
658-2806-103F	BLUE DIFF.	BLUE	BLACK	8-60VDC	6.0 [152,4] ±.13 [3,3]
			BLUE		

REV	ECN NO	REVISIONS	DRN	CKD	APP	DATE
A	117123	NEW RELEASE	JSG	JY	JV	18APR24

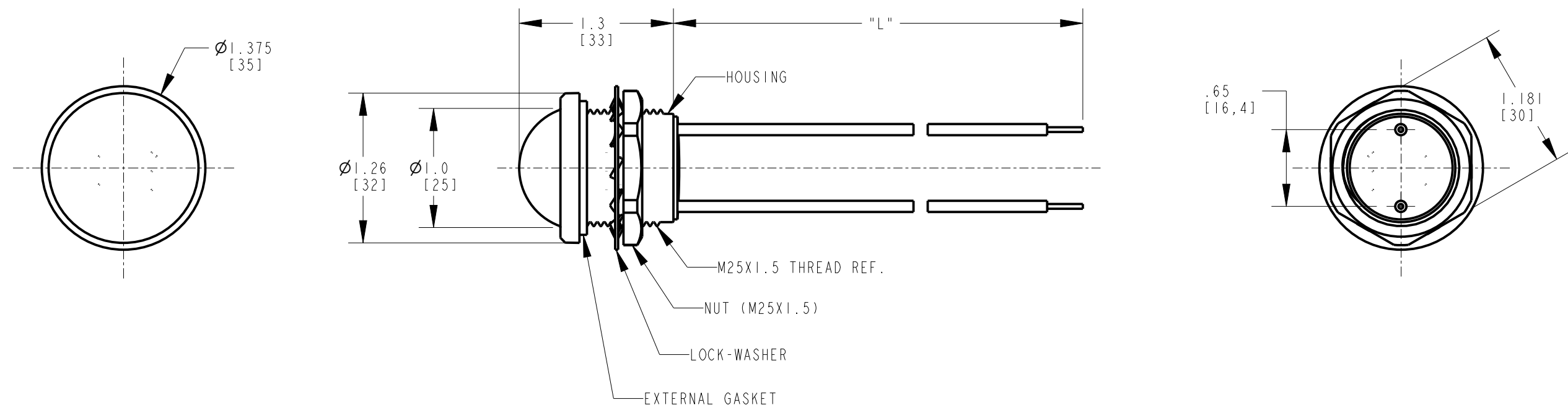

NOTES:

1. MOUNTING HOLE SIZE : 1.00" (25.40mm)
2. MAXIMUM PANEL THICKNESS : 0.350" (8.89mm)
3. PRODUCT IS WATER SEALED FROM FRONT PANEL
4. MOUNTING TORQUE : 5IN-LB FOR WATER TIGHT SEAL
5. MATERIAL :
 - 1) HOUSING/LENS : POLYCARBONATE
 - 2) EXTERNAL SEALING GASKET : NEOPRENE
 - 3) LOCK WASHER : NICKEL PLATED BRONZE
 - 4) NUT : NICKEL PLATED BRASS
6. HARDWARE IS PACKAGED IN A SEPARATE BAG.
7. THIS ASSEMBLY CONTAINS ELECTROSTATIC DISCHARGE SENSITIVE DEVICES (ESDS).
8. THIS PRODUCT IS RoHS COMPLIANT, EACH BAG IS MARKED WITH RoHS COMPLIANT LABEL OR EQUIVALENT MARKINGS.

THIS DRAWING AND THE CONTENTS HEREIN ARE CONFIDENTIAL AND THE SOLE PROPERTY OF DIALIGHT CORP. REPRODUCTION OF THIS DRAWING OR CONSTRUCTION OF ANY PARTS WITHIN THIS DRAWING ARE FORBIDDEN WITHOUT THE WRITTEN CONSENT OF DIALIGHT CORP.

DIALIGHT CORP. INTERNAL REFERENCE ONLY = 3D MODEL : 6582X05103F-A.6

SCALE: 1.000	DRAWING NUMBER	REV
ALL DIM'S: INCH (mm)	C-18744	A
TOLERANCES: UNLESS OTHERWISE SPECIFIED	TITLE PMI, DOME, 8-60 VDC COLOR LENS	
FRACTIONS: ±1/64 DECIMALS (.XX): ±.01 DECIMALS (.XXX): ±.005 DECIMALS (.XXXX): ±.0005 ANGLES: ±1°	MATERIAL —	
FINISH —		
FSCM 83330	SHEET 1 OF 1	FAMILY TABLE:

1501 ROUTE 34 SOUTH
FARMINGDALE, NJ 07727
(732) 919-3119
www.dialight.com