



# LKM

- ◆ 小体积 耐高频大纹波电流 高频低阻抗 电源专用产品
- ◆ 105℃环境下 7000小时~10000小时
- ◆ 符合AEC-Q200 RoHS指令对应



## ■ 主要技术参数

项目	特性						
使用温度范围	≤120V.DC -55℃~+105℃ ; 160~500V.DC -40℃~+105℃						
标称电压范围	10~500V.DC						
容量允许偏差	±20% (25±2℃ 120Hz)						
漏电流(μA)	10~120WV I≤0.01CV or 3μA取大者 C:标称容量(μF) V:额定电压(V) 2分钟读数						
	160~500WV I≤0.02CV+10(μA) C:标称容量(μF) V:额定电压(V) 2分钟读数						
损耗角正切值 (25±2℃ 120Hz)	额定电压(V)	10 16 25 35 50 63 80 100					
	tg δ	0.19 0.16 0.14 0.12 0.10 0.09 0.09 0.09					
	额定电压(V)	120 160 200 250 350 400 450 500					
	tg δ	0.09 0.09 0.08 0.08 0.10 0.10 0.12 0.20					
标称容量超过1000μF者, 则每增加1000μF, 损耗角正切值增加0.02							
温度特性 (120Hz)	额定电压(V)	10 16 25 35 50 63 80 100					
	阻抗比Z(-40℃)/Z(20℃)	6 4 3 3 3 3 3 3					
	额定电压(V)	120 160 200 250 350 400 450 500					
	阻抗比Z(-40℃)/Z(20℃)	5 5 5 5 7 7 7 8					
耐久性	在105℃烘箱中, 施加含额定纹波电流的额定电压, 持续规定时间后, 置于常温16小时后测试, 测试温度25±2℃, 电容器的性能应满足如下要求						
	容量变化率	在初始值的±20%以内					
	损耗角正切值	在规定值的200%以下					
	漏电流	在规定值以下					
	负荷寿命	<table border="1"> <tr> <td>φ 5</td> <td>7000小时</td> </tr> <tr> <td>φ 6.3</td> <td>9000小时</td> </tr> <tr> <td>≥ φ 8</td> <td>10000小时</td> </tr> </table>	φ 5	7000小时	φ 6.3	9000小时	≥ φ 8
φ 5	7000小时						
φ 6.3	9000小时						
≥ φ 8	10000小时						
高温储存	在105℃下, 储存1000小时, 置于常温16小时后测试, 测试温度: 25±2℃, 电容器的性能应满足如下要求						
	容量变化率	在初始值的±20%以内					
	损耗角正切值	在规定值的200%以下					
	漏电流	在规定值的200%以下					





# LKM

## ■ 标准品一览表

电压(V)	10			16			25			35		
项目 容量 ( $\mu F$ )	尺寸 D×L(mm)	阻抗 ( $\Omega_{max/100kHz}$ 25±2℃)	纹波电流 (mA r.m.s/ 105℃ 100kHz)	尺寸 D×L(mm)	阻抗 ( $\Omega_{max/100kHz}$ 25±2℃)	纹波电流 (mA r.m.s/ 105℃ 100kHz)	尺寸 D×L(mm)	阻抗 ( $\Omega_{max/100kHz}$ 25±2℃)	纹波电流 (mA r.m.s/ 105℃ 100kHz)	尺寸 D×L(mm)	阻抗 ( $\Omega_{max/100kHz}$ 25±2℃)	纹波电流 (mA r.m.s/ 105℃ 100kHz)
10	5×9	1.10	56	5×9	1.10	71	5×9	1.10	91	5×9	1.40	101
15	5×9	1.10	76	5×9	1.10	91	5×9	1.10	111	5×9	1.10	121
22	5×9	0.40	91	5×9	0.40	111	5×9	1.10	121	5×9	1.10	160
33	5×9	0.40	106	5×9	0.40	121	5×9	0.40	151	5×9	0.40	215
39	5×9	0.26	136	5×9	0.40	151	5×9	0.40	181	5×9	0.40	345
47	5×9	0.26	143	5×9	0.26	161	5×9	0.26	211	5×9	0.37	345
56	5×9	0.26	151	5×9	0.26	171	5×9	0.26	310	5×9	0.37	414
68	5×9	0.26	161	5×9	0.26	181	5×9	0.24	345	5×11	0.34	443
68										6.3×9	0.34	486
82	5×9	0.26	171	5×9	0.26	211	5×9	0.34	414	5×11	0.28	486
82										6.3×9	0.28	540
100	5×9	0.26	181	5×9	0.24	345	5×9	0.34	443	6.3×9	0.28	550
120	5×9	0.26	211	5×9	0.24	345	5×11	0.34	486	6.3×9	0.28	550
120							6.3×9	0.28	486			
150	5×9	0.26	345	5×9	0.34	414	6.3×9	0.28	540	6.3×11	0.21	660
150										8×9	0.21	660
180	5×9	0.26	345	5×11	0.34	443	6.3×9	0.28	550	8×9	0.21	900
180				6.3×9	0.34	486						
220	5×9	0.34	414	6.3×9	0.28	540	6.3×11	0.21	660	8×9	0.15	945
220							8×9	0.21	660			
270	5×11	0.34	443	6.3×9	0.28	540	8×9	0.15	900	8×11.5	0.1200	1250
270	6.3×9	0.34	486							10×9	0.1200	1250
330	6.3×9	0.15	540	6.3×11	0.21	550	8×9	0.1500	945	8×14	0.0900	1330
330				8×9	0.21	550				10×12.5	0.0900	1330
390	6.3×9	0.15	540	8×9	0.15	660	8×11.5	0.0980	1250	8×16	0.076	1420
390							10×9	0.0980	1250	10×12.5	0.076	1760
470	6.3×11	0.15	545	8×9	0.15	900	8×11.5	0.0980	1330	10×14	0.0590	1850
470	8×9	0.15	550				10×9	0.0980	1330			
560	6.3×11	0.12	880	8×9	0.15	900	8×14	0.0760	1420	10×14	0.0590	1960
560	8×9	0.12	900				10×12.5	0.0760	1760			
680	8×9	0.12	900	8×11.5	0.0980	1250	8×16	0.0590	1500	10×16	0.0520	2120
680				10×9	0.0980	1330	10×12.5	0.0590	1760	12.5×14	0.0520	2120
820	8×9	0.12	1180	8×14	0.0760	1420	10×14	0.0460	1850	12.5×14	0.0520	2360
820				10×12.5	0.0760	1760						
1000	8×11.5	0.0980	1250	8×16	0.0590	1500	10×16	0.0420	1960	12.5×16	0.0420	2480
1000	10×9	0.0980	1330	10×12.5	0.0590	1850	12.5×14	0.0420	2120			
1200	8×14	0.0760	1420	10×14	0.0460	1850	10×20	0.0320	2120	12.5×20	0.0380	2900
1200	10×12.5	0.0760	1760				12.5×14	0.0320	2120			
1500	8×16	0.0590	1500	10×16	0.0420	1960	10×20	0.0280	2480	12.5×20	0.0380	2900



# LKM

## ■ 标准品一览表

电压(V)	10			16			25			35		
项目 容量 ( $\mu F$ )	尺寸 D×L(mm)	阻抗 ( $\Omega_{max}/100KHz$ 25±2℃)	纹波电流 (mA r.m.s/ 105℃ 100KHz)	尺寸 D×L(mm)	阻抗 ( $\Omega_{max}/100KHz$ 25±2℃)	纹波电流 (mA r.m.s/ 105℃ 100KHz)	尺寸 D×L(mm)	阻抗 ( $\Omega_{max}/100KHz$ 25±2℃)	纹波电流 (mA r.m.s/ 105℃ 100KHz)	尺寸 D×L(mm)	阻抗 ( $\Omega_{max}/100KHz$ 25±2℃)	纹波电流 (mA r.m.s/ 105℃ 100KHz)
1500	10×12.5	0.0590	1760	12.5×14	0.0420	2120	12.5×16	0.0280	2480	16×16	0.0380	3250
1800	10×14	0.0460	1850	10×20	0.0380	1960	12.5×16	0.0280	2480	12.5×25	0.0350	3450
1800				12.5×14	0.0420	2120				16×20	0.0350	3630
2200	10×16	0.0420	1960	10×20	0.0380	2480	12.5×20	0.0270	2900	12.5×30	0.0320	3630
2200	12.5×14	0.0420	2120	12.5×16	0.0380	2480	16×16	0.0270	3250	16×20	0.0320	3630
2700	10×20	0.0320	2250	12.5×16	0.0380	2480	12.5×25	0.0265	3450	16×25	0.0230	3890
2700	12.5×14	0.0320	2250				16×20	0.0265	3630	18×20	0.0230	4010
3300	10×23	0.0280	2480	12.5×20	0.0280	2900	12.5×30	0.0260	3630	16×31.5	0.0100	4080
3300	12.5×16	0.0280	2480				16×20	0.0260	3630	18×25	0.0100	4080
3900	12.5×16	0.0280	2900	12.5×25	0.0230	3250	16×25	0.0171	3890	18×25	0.0100	4080
3900				16×16	0.0230	3450	18×20	0.0171	3650			
4700	12.5×20	0.0230	3250	12.5×25	0.0210	3450	16×25	0.0121	3890			
4700	16×16	0.0230	3450	16×20	0.0210	3630	18×20	0.0110	4010			

电压(V)	50			63			80			100		
项目 容量 ( $\mu F$ )	尺寸 D×L(mm)	阻抗 ( $\Omega_{max}/100KHz$ 25±2℃)	纹波电流 (mA r.m.s/ 105℃ 100KHz)	尺寸 D×L(mm)	阻抗 ( $\Omega_{max}/100KHz$ 25±2℃)	纹波电流 (mA r.m.s/ 105℃ 100KHz)	尺寸 D×L(mm)	阻抗 ( $\Omega_{max}/100KHz$ 25±2℃)	纹波电流 (mA r.m.s/ 105℃ 100KHz)	尺寸 D×L(mm)	阻抗 ( $\Omega_{max}/100KHz$ 25±2℃)	纹波电流 (mA r.m.s/ 105℃ 100KHz)
0.47	5×9	5.50	21	5×9	5.00	23	5×9	6.05	24	5×9	6.05	24
1.0	5×9	5.50	31	5×9	5.00	35	5×9	6.05	37	5×9	6.05	37
1.2				5×9	5.00	35	5×9	6.05	37	5×9	6.05	37
1.5				5×9	5.00	41	5×9	6.05	43	5×9	6.05	43
1.8	5×9	5.50	32	5×9	5.00	41	5×9	6.05	43	5×9	6.05	43
2.2	5×9	1.50	39	5×9	1.50	45	5×9	1.50	47	5×9	1.60	47
2.7				5×9	1.50	52	5×9	1.50	55	5×9	1.60	55
3.3	5×9	1.50	54	5×9	1.50	59	5×9	1.50	62	5×9	1.60	62
3.9	5×9	1.50	54	5×9	1.50	78	5×9	1.50	81	5×9	1.60	81
4.7	5×9	1.50	89	5×9	1.50	98	5×9	1.50	101	5×9	1.60	101
5.6	5×9	1.50	91	5×9	1.50	100	5×9	1.50	106	5×9	1.40	106
6.8	5×9	1.50	94	5×9	1.50	103	5×9	1.50	111	5×9	1.40	111
8.2	5×9	1.50	98	5×9	1.50	109	5×9	1.50	121	5×9	1.40	121
10	5×9	1.50	101	5×9	1.50	111	5×9	1.40	150	5×9	0.80	220
12				5×9	1.50	121	5×9	1.40	163	5×11	0.80	267
12										6.3×9	0.80	267
15	5×9	1.50	121	5×9	1.50	150	5×9	1.10	200	5×11	0.80	267
15										6.3×9	0.80	267
18				5×9	1.1	173	5×9	0.86	240	6.3×9	0.63	267





# LKM

## ■ 标准品一览表

电压(V)	50			63			80			100		
项目 容量 ( $\mu F$ )	尺寸 D×L(mm)	阻抗 ( $\Omega_{max/100KHz}$ 25±2℃)	纹波电流 (mA r.m.s/ 105℃ 100KHz)	尺寸 D×L(mm)	阻抗 ( $\Omega_{max/100KHz}$ 25±2℃)	纹波电流 (mA r.m.s/ 105℃ 100KHz)	尺寸 D×L(mm)	阻抗 ( $\Omega_{max/100KHz}$ 25±2℃)	纹波电流 (mA r.m.s/ 105℃ 100KHz)	尺寸 D×L(mm)	阻抗 ( $\Omega_{max/100KHz}$ 25±2℃)	纹波电流 (mA r.m.s/ 105℃ 100KHz)
22	5×9	1.10	238	5×9	0.86	228	5×11	0.63	250	6.3×9	0.63	290
22							6.3×9	0.63	267			
27	5×9	0.86	286	5×9	0.58	250	6.3×9	0.63	267	6.3×11	0.63	420
27										8×9	0.63	450
33	5×9	0.58	314	5×11	0.39	300	6.3×9	0.63	267	8×9	0.40	450
33				6.3×9	0.39	344						
39	5×11	0.36	344	6.3×9	0.39	344	6.3×11	0.63	400	8×9	0.28	565
39	6.3×9	0.36	344				8×9	0.63	420			
47	5×11	0.36	344	6.3×9	0.39	385	6.3×11	0.63	420	8×11.5	0.28	585
47	6.3×9	0.34	385				8×9	0.63	470	10×9	0.28	624
56	6.3×9	0.34	385	6.3×11	0.24	492	8×9	0.63	470	8×14	0.25	624
56				8×9	0.24	525				10×9	0.25	624
68	6.3×9	0.34	390	6.3×11	0.24	724	8×9	0.49	520	8×16	0.21	735
68				8×9	0.24	724				10×12.5	0.21	750
82	6.3×11	0.24	487	8×9	0.24	724	8×11.5	0.38	624	8×16	0.19	780
82	8×9	0.24	724				10×9	0.25	668	10×14	0.19	900
100	6.3×11	0.18	687	8×9	0.24	902	8×14	0.21	735	10×14	0.14	1040
100	8×9	0.18	724				10×9	0.19	744			
120	8×9	0.18	800	8×11.5	0.19	902	8×16	0.19	744	10×16	0.12	1170
120				10×9	0.19	979	10×12.5	0.19	892	12.5×14	0.12	1240
150	8×11.5	0.14	950	8×14	0.19	950	10×14	0.15	980	12.5×14	0.0930	1368
150	10×9	0.14	975	10×12.5	0.19	1130						
180	8×14	0.11	1190	8×16	0.19	1190	10×14	0.15	980	12.5×16	0.0660	1530
180	10×12.5	0.11	1230	10×14	0.19	1190						
220	8×14	0.0950	1190	10×14	0.14	1200	10×16	0.13	1040	12.5×20	0.0660	1620
220	10×12.5	0.0950	1230				12.5×14	0.13	1040			
270	8×16	0.0740	1420	10×16	0.0860	1300	10×20	0.0940	1240	12.5×20	0.0560	1750
270	10×14	0.0740	1420	12.5×14	0.0902	1500	12.5×16	0.0940	1240	16×16	0.0640	1750
330	10×14	0.0740	1450	10×16	0.0860	1580	12.5×16	0.0940	1368	12.5×25	0.0470	2140
330				12.5×14	0.0660	1650				16×20	0.0480	2210
390	10×16	0.0580	1580	10×20	0.0660	1870	12.5×20	0.0640	1640	12.5×30	0.0400	2210
390	12.5×14	0.0580	1650	12.5×16	0.0660	1870	16×16	0.0640	1750	16×20	0.0480	2210
470	12.5×14	0.0580	2050	12.5×16	0.0500	2100	12.5×20	0.0640	1750	16×25	0.0480	2400
470							16×16	0.0480	1750	18×20	0.0420	2270
560	12.5×16	0.0500	2050	12.5×20	0.0473	2410	12.5×25	0.0480	2110	16×25	0.0320	2600
560				16×16	0.0473	2500	16×20	0.0480	2110			
680	12.5×16	0.0500	2250	12.5×25	0.0473	2410	12.5×30	0.0420	2270	16×31.5	0.0300	2860
680				16×16	0.0385	2730	16×20	0.0420	2270	18×25	0.0300	2860
820	12.5×20	0.0390	2410	12.5×30	0.0360	2620	16×25	0.0320	2600	18×31.5	0.0290	3510



# LKM

## ■ 标准品一览表

电压(V)	50			63			80			100		
项目 容量 ( $\mu F$ )	尺寸 D×L(mm)	阻抗 ( $\Omega_{max}/100KHz$ 25±2℃)	纹波电流 (mA r.m.s/ 105℃ 100KHz)	尺寸 D×L(mm)	阻抗 ( $\Omega_{max}/100KHz$ 25±2℃)	纹波电流 (mA r.m.s/ 105℃ 100KHz)	尺寸 D×L(mm)	阻抗 ( $\Omega_{max}/100KHz$ 25±2℃)	纹波电流 (mA r.m.s/ 105℃ 100KHz)	尺寸 D×L(mm)	阻抗 ( $\Omega_{max}/100KHz$ 25±2℃)	纹波电流 (mA r.m.s/ 105℃ 100KHz)
820	16×16	0.0390	2730	16×20	0.0350	2730	18×20	0.0420	2270			
1000	12.5×25	0.0390	2860	16×20	0.0350	2860	16×31.5	0.0300	2860			
1000	16×16	0.0390	3010				18×25	0.0340	2470			
1200	12.5×25	0.0340	3280	16×25	0.0340	2990	18×25	0.0300	2860			
1200	16×20	0.0340	3300	18×20	0.0340	3300						
1500	12.5×30	0.0260	3280	16×25	0.0280	3280	18×31.5	0.0290	3510			
1500	16×25	0.0340	3300									
1800	16×25	0.0280	3300	16×31.5	0.0280	3570						
1800	18×20	0.0280	3300	18×25	0.0280	3570						
2200	18×25	0.0280	3570	18×31.5	0.0260	3670						
2700	18×31.5	0.0260	3670									

电压(V)	120			160			200			250		
项目 容量 ( $\mu F$ )	尺寸 D×L(mm)	阻抗 ( $\Omega_{max}/100KHz$ 25±2℃)	纹波电流 (mA r.m.s/ 105℃ 100KHz)	尺寸 D×L(mm)	阻抗 ( $\Omega_{max}/100KHz$ 25±2℃)	纹波电流 (mA r.m.s/ 105℃ 100KHz)	尺寸 D×L(mm)	阻抗 ( $\Omega_{max}/100KHz$ 25±2℃)	纹波电流 (mA r.m.s/ 105℃ 100KHz)	尺寸 D×L(mm)	阻抗 ( $\Omega_{max}/100KHz$ 25±2℃)	纹波电流 (mA r.m.s/ 105℃ 100KHz)
0.47	5×9	6.05	24									
1.0	5×9	6.05	37	5×9	28.00	68	5×9	28.00	50	5×9	28.00	56
1.2	5×9	6.05	37	5×9	28.00	68	5×9	28.00	55	5×9	28.00	56
1.5	5×9	6.05	43	5×9	28.00	95	5×9	28.00	60	5×9	28.00	56
1.8	5×9	6.05	43	5×9	28.00	95	5×9	28.00	65	5×9	28.00	65
2.2	5×9	1.60	47	5×9	28.00	95	5×9	28.00	75	5×9	28.00	98
2.7	5×9	1.60	55	5×9	28.00	95	5×9	28.00	80	5×9	28.00	98
3.3	5×9	1.60	62	5×9	28.00	95	5×9	28.00	95	5×9	28.00	98
3.9	5×9	1.60	81	5×9	28.00	95	5×9	28.00	95	5×11	23.00	114
3.9										6.3×9	15.60	135
4.7	5×9	1.60	101	5×9	23.00	95	5×11	23.00	104	6.3×9	15.60	135
4.7							6.3×9	15.60	125			
5.6	5×9	1.60	106	5×11	23.00	104	6.3×9	15.60	125	6.3×9	15.60	140
5.6				6.3×9	23.00	110						
6.8	5×11	1.40	111	6.3×9	18.00	125	6.3×9	15.60	140	6.3×11	14.90	140
6.8										8×9	14.90	140
8.2	5×11	1.40	127	6.3×9	18.00	125	6.3×11	14.90	140	6.3×12	12.50	150
8.2							8×9	14.90	140	8×9	12.50	170
10	6.3×9	1.10	220	6.3×11	15.00	132	6.3×12	12.50	160	8×9	10.00	210
10				8×9	15.00	140	8×9	12.50	170			
12	6.3×9	1.10	220	6.3×12	12.50	140	8×11.5	7.00	210	8×11.5	7.00	270





# LKM

## ■ 标准品一览表

电压(V)	120			160			200			250		
项目 容量 ( $\mu F$ )	尺寸 D×L(mm)	阻抗 ( $\Omega_{max}/100kHz$ 25±2℃)	纹波电流 (mA r.m.s/ 105℃ 100kHz)	尺寸 D×L(mm)	阻抗 ( $\Omega_{max}/100kHz$ 25±2℃)	纹波电流 (mA r.m.s/ 105℃ 100kHz)	尺寸 D×L(mm)	阻抗 ( $\Omega_{max}/100kHz$ 25±2℃)	纹波电流 (mA r.m.s/ 105℃ 100kHz)	尺寸 D×L(mm)	阻抗 ( $\Omega_{max}/100kHz$ 25±2℃)	纹波电流 (mA r.m.s/ 105℃ 100kHz)
12				8×9	12.50	150						
15	6.3×11	0.80	267	6.3×12	12.50	140	8×11.5	4.90	256	8×11.5	4.90	270
15	8×9	0.80	267	8×9	12.50	150	10×9	4.90	280	10×9	4.90	280
18	8×9	0.80	267	8×11.5	9.70	160	8×14	3.58	280	8×14	3.58	280
18				10×9	12.50	160	10×12.5	3.58	320	10×12.5	3.58	320
22	8×9	0.80	290	8×11.5	7.90	160	8×16	3.58	320	8×16	3.58	320
22				10×9	7.90	250	10×12.5	3.58	320	10×12.5	3.58	320
27	8×11.5	0.63	420	8×14	7.90	250						
27				10×12.5	7.90	250						
33	8×11.5	0.49	450	8×16	5.90	350	8×23	1.78	603	8×23	1.78	603
33	10×9	0.49	450	10×12.5	5.90	360	10×16	1.78	708	10×16	1.78	708
39	8×14	0.38	565	8×20	5.55	580						
39	10×12.5	0.38	565	10×14	5.55	635						
47	8×16	0.28	585	8×23	5.55	635	10×20	1.46	745	10×20	1.46	850
47	10×12.5	0.28	624	10×16	5.55	680	12.5×16	1.46	960	12.5×16	1.46	960
56	8×20	0.25	624	10×16	5.55	850	10×23	1.46	960	10×23	1.46	960
56	10×14	0.25	624	12.5×14	5.55	850	12.5×16	1.46	960	12.5×16	1.46	960
68	8×23	0.21	735	10×20	5.55	850	12.5×20	1.35	1270	12.5×20	1.35	1270
68	10×16	0.21	750	12.5×14	5.55	850	16×16	1.35	1270	16×16	1.35	1270
82	10×16	0.19	780	10×20	4.36	1020	12.5×20	1.35	1270	12.5×20	1.35	1270
82	12.5×14	0.19	900	12.5×16	4.36	1155	16×16	1.35	1270	16×16	1.35	1270
100	10×20	0.14	1040	12.5×16	4.36	1155	12.5×20	1.35	1360	12.5×25	1.32	1360
100	12.5×16	0.14	1040				16×16	1.35	1270	16×20	1.32	1410
120	10×23	0.12	1170	12.5×20	3.41	1390	12.5×25	1.25	1360	16×20	1.25	1500
120	12.5×16	0.12	1240	16×16	3.01	1420	16×20	1.32	1850			
150	12.5×20	0.0930	1368	12.5×25	3.01	1520	16×20	1.20	1660	16×25	1.25	1800
150				16×20	2.31	1850				18×20	1.25	1920
180	12.5×25	0.0660	1530	12.5×30	2.31	1850	16×25	0.95	2020	16×31.5	0.95	2250
180				16×20	2.31	1850	18×20	0.95	2020	18×25	0.95	2250
220	16×20	0.0660	1620	16×25	1.88	2400	18×25	0.91	2380	18×31.5	0.91	2625
220				18×20	1.88	2320						
270	12.5×30	0.0560	1750	16×31.5	1.80	2715						
270	16×20	0.0640	1750	18×25	0.98	2660						
330	16×25	0.0470	2140	18×25	0.98	2660						
330	18×20	0.0480	2140									
390	16×31.5	0.0400	2210	18×31.5	0.91	2715						
390	18×25	0.0400	2210									
470	16×31.5	0.0400	2270									
470	18×25	0.0400	2270									





# LKM

## ■ 标准品一览表

电压(V)	120			160			200			250		
项目 容量 ( $\mu F$ )	尺寸 D×L(mm)	阻抗 ( $\Omega_{max/100kHz}$ 25±2℃)	纹波电流 (mA r.m.s/ 105℃ 100kHz)	尺寸 D×L(mm)	阻抗 ( $\Omega_{max/100kHz}$ 25±2℃)	纹波电流 (mA r.m.s/ 105℃ 100kHz)	尺寸 D×L(mm)	阻抗 ( $\Omega_{max/100kHz}$ 25±2℃)	纹波电流 (mA r.m.s/ 105℃ 100kHz)	尺寸 D×L(mm)	阻抗 ( $\Omega_{max/100kHz}$ 25±2℃)	纹波电流 (mA r.m.s/ 105℃ 100kHz)
560	16×35.5	0.0320	2600									
560	18×31.5	0.0320	2600									
680	18×35.5	0.0300	2860									

电压(V)	350			400			450			500		
项目 容量 ( $\mu F$ )	尺寸 D×L(mm)	阻抗 ( $\Omega_{max/100kHz}$ 25±2℃)	纹波电流 (mA r.m.s/ 105℃ 100kHz)	尺寸 D×L(mm)	阻抗 ( $\Omega_{max/100kHz}$ 25±2℃)	纹波电流 (mA r.m.s/ 105℃ 100kHz)	尺寸 D×L(mm)	阻抗 ( $\Omega_{max/100kHz}$ 25±2℃)	纹波电流 (mA r.m.s/ 105℃ 100kHz)	尺寸 D×L(mm)	阻抗 ( $\Omega_{max/100kHz}$ 25±2℃)	纹波电流 (mA r.m.s/ 105℃ 100kHz)
1.0	5×9	55.00	73	5×9	55.00	73	5×9	55.00	73	6.3×9	52.00	45
1.2	5×9	36.00	90	5×9	36.00	76	5×9	52.00	78	6.3×9	52.00	45
1.5	5×9	36.00	90	5×9	36.00	76	5×11	52.00	81	6.3×9	52.00	45
1.5							6.3×9	52.00	90			
1.8	5×9	36.00	95	5×9	36.00	87	6.3×9	52.00	95	8×9	45.00	80
2.2	5×11	36.00	104	6.3×9	29.00	105	6.3×9	42.00	100	8×9	45.00	80
2.2	6.3×9	36.00	125									
2.7	6.3×9	26.00	125	6.3×9	26.00	125	6.3×9	42.00	100	8×11.5	18.50	85
3.3	6.3×9	23.00	131	6.3×9	25.00	131	6.3×12	25.00	120	8×11.5	18.50	85
3.3							8×9	25.00	120			
3.9	6.3×11	17.00	131	6.3×11	25.00	140	8×9	25.00	135	8×14	13.00	85
3.9	8×9	17.00	131	8×9	23.50	140						
4.7	6.3×11	17.00	140	6.3×12	23.50	140	8×11.5	18.50	135	8×16	13.00	130
4.7	8×9	17.00	140	8×9	23.50	140	10×9	18.50	135			
5.6	8×9	17.00	140	8×11.5	15.00	200	8×14	15.00	140	10×14	13.00	130
5.6				10×9	15.00	220	10×9	13.50	140			
6.8	8×11.5	15.00	200	8×11.5	15.00	210	8×16	8.05	220	10×14	13.00	130
6.8	10×9	17.00	210	10×9	15.00	250	10×12.5	12.00	200			
8.2	8×14	11.25	220	8×14	11.00	250	8×16	8.05	220	10×14	11.00	240
8.2	10×9	15.00	250	10×9	11.00	270	10×12.5	12.00	200			
10	8×14	8.05	250	8×16	8.05	270	8×20	8.05	260	8×23	11.00	240
10	10×12.5	11.00	270	10×12.5	11.00	270	10×14	8.05	350	10×16	10.00	260
12	8×20	9.00	360	10×14	9.00	340	10×16	7.90	370	12.5×14	9.50	265
15	8×20	6.50	360	10×14	8.50	340	10×16	7.70	370	12.5×16	8.00	270
15	10×14	6.50	460				12.5×14	7.70	370			
18	10×16	6.50	480	10×16	6.50	360	12.5×16	6.70	410	12.5×16	7.00	470
18	12.5×14	6.50	585	12.5×14	6.50	360						
22	10×20	6.50	585	10×20	6.50	570	12.5×16	6.70	450	12.5×20	7.00	470
22	12.5×14	6.50	585	12.5×16	6.50	570						





# LKM

## ■ 标准品一览表

电压(V)	350			400			450			500		
项目 容量 ( $\mu F$ )	尺寸 D×L(mm)	阻抗 ( $\Omega_{max}/100kHz$ 25±2℃)	纹波电流 (mA r.m.s/ 105℃ 100kHz)	尺寸 D×L(mm)	阻抗 ( $\Omega_{max}/100kHz$ 25±2℃)	纹波电流 (mA r.m.s/ 105℃ 100kHz)	尺寸 D×L(mm)	阻抗 ( $\Omega_{max}/100kHz$ 25±2℃)	纹波电流 (mA r.m.s/ 105℃ 100kHz)	尺寸 D×L(mm)	阻抗 ( $\Omega_{max}/100kHz$ 25±2℃)	纹波电流 (mA r.m.s/ 105℃ 100kHz)
33	12.5×16	6.50	960	12.5×20	3.25	850	12.5×20	3.05	710	12.5×25	5.50	700
33				16×16	3.25	900	16×16	3.05	740	16×20	3.50	700
47	12.5×20	2.25	1115	12.5×25	2.25	1100	12.5×30	1.60	1215	16×25	2.50	720
47	16×16	2.25	1060	16×20	2.25	1155	16×20	1.60	1215			
56	12.5×25	2.25	1115	12.5×25	2.25	1155	16×25	1.60	1215	16×31.5	2.30	840
56	16×20	2.25	1155	16×20	2.25	1400	18×20	1.60	1300	18×25	2.30	840
68	12.5×30	2.25	1115	16×25	1.60	1460	16×31.5	1.60	1215	18×25	2.30	840
68	16×20	2.25	1400	18×20	1.60	1530	18×25	1.60	1215			
82	16×25	1.60	1550	16×31.5	1.60	1740	16×35.5	1.35	1675	18×31.5	1.80	1100
82	18×20	1.60	1530	18×25	1.60	1740	18×25	1.45	1700			
100	16×25	1.60	2230	18×25	1.60	1740	18×31.5	1.35	1800	18×35.5	1.50	1150
120	18×25	1.60	2305	18×31.5	1.50	2305	18×35.5	1.25	1930	18×40	1.40	1200
150	18×31.5	1.50	2720	18×35.5	1.50	3330	18×40	1.15	2350			

## ■ 产品尺寸图 (单位: mm)

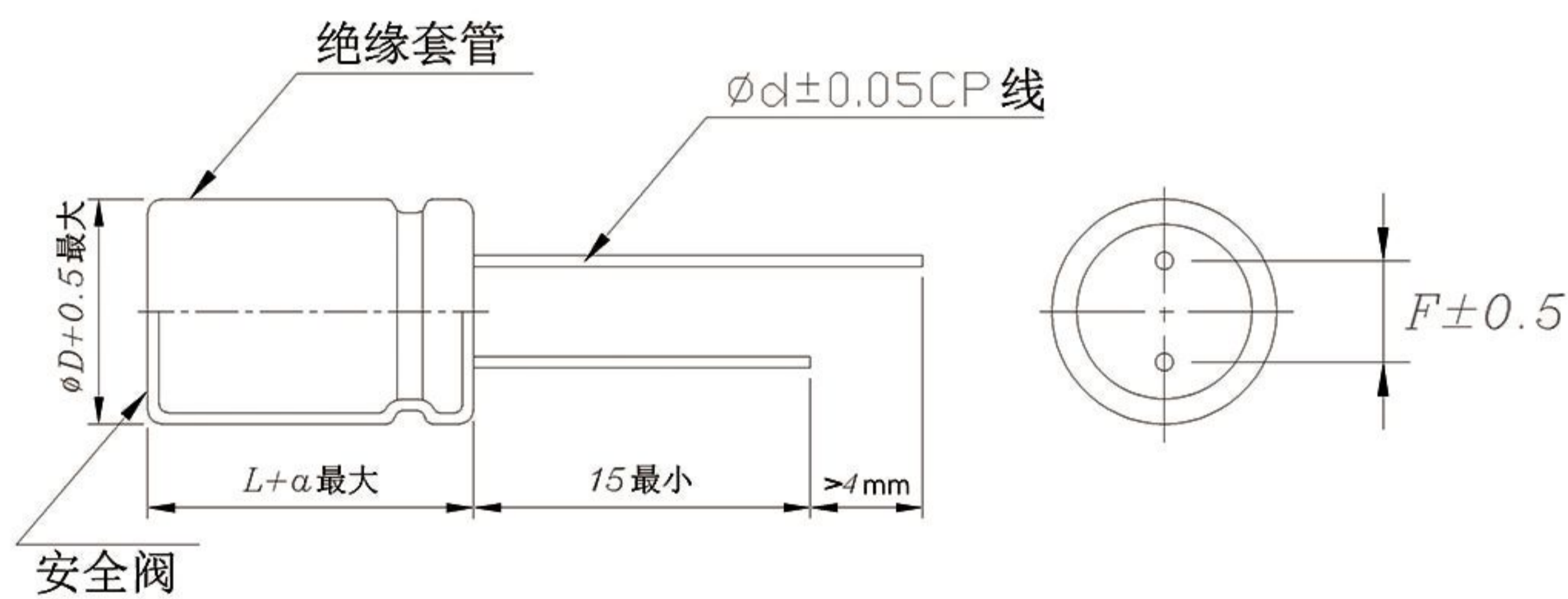

备注:  $\geq \phi 6.3$  产品有安全阀

L=9	a=1.0
L≤16	a=1.5
L>16	a=2.0

D	5	6.3	8	10	12.5	16	18
d	0.5	0.5	0.6	0.6	0.6	0.8	0.8
F	2.0	2.5	3.5	5.0	5.0	7.5	7.5

## ■ 纹波电流补偿系数

### ① 频率修正系数

频率	50	120	1K	10K~50K	100K
修正因子	0.40	0.50	0.80	0.90	1.00

### ② 温度修正系数

环境温度(℃)	50℃	70℃	85℃	105℃
修正因子	2.1	1.8	1.4	1.0