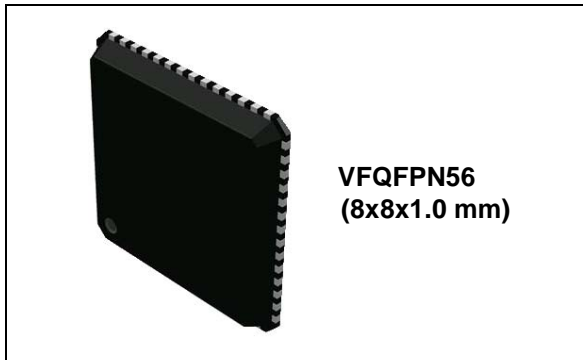

Fully Integrated GPS/Galileo/GLONASS/BeiDou/QZSS receiver

Data brief

**Features**

- STMicroelectronics® positioning receiver with 48 tracking channels and 2 fast acquisition channels supporting GPS, Galileo, GLONASS, BeiDou and QZSS systems
- Single die standalone receiver embedding RF Front-End and low noise amplifier
- -162 dBm indoor sensitivity (tracking mode)
- Fast TTFF < 1 s in Hot start and 30 s in Cold Start
- High performance ARM946 MCU (up to 196 MHz)
- External SQI Flash interface
- 256 Kbyte embedded SRAM
- Real Time Clock (RTC) circuit
- 32-bit Watch-dog timer
- 2 UARTs
- 1 I²C master/slave interface
- USB2.0 full speed (12 MHz) with integrated physical layer transceiver
- 2 Controller Area Network (CAN)
- 2 channels ADC (10 bits)

- Operating condition:
 - Main voltage regulator (V_{INL}): 1.6 V to 4.3 V
 - Backup voltage (V_{INB}): 1.6 V to 4.3 V
 - Digital voltage (V_{DDD}): 1.1 V to 1.32 V
 - RF core voltage (V_{CC}): 1.2 V \pm 10%
 - IO Ring Voltage (V_{ddIO}): 1.8 V \pm 5% or 3.3 V \pm 10%
- Package:
 - VFQFPN56 (8 x 8 x 1.0 mm) 0.5 mm pitch
- Ambient temperature range: -40/+85°C

Description

STA8090GA belongs to Teseo III family products.

STA8090GA is a single die standalone positioning receiver IC working on multiple constellations (GPS/Galileo/GLONASS/BeiDou/QZSS).

The device is offered with a complete GNSS firmware which performs all GNSS operations including tracking, acquisition, navigation and data output.

STA8090GA is compliant with ST Automotive Grade qualification which includes in addition to AEC-Q100 requirements a set of production flow methodologies targeting zero defect per million.

STA8090GA, fulfilling high quality and service level requirements of the Automotive market, is the ideal solution for in-dash navigation, smart antenna, car to car, V2X and OEM telematics applications.

STA8090GA can run also TESEO-DRAW the STMicroelectronics dead reckoning firmware.

Contents

- 1 Overview 5**
- 2 Pin description 6**
 - 2.1 Block diagram 6
 - 2.2 VFQFPN56 pin configuration 7
 - 2.3 Power supply pins 8
 - 2.4 Main function pins 9
 - 2.5 Test/emulated dedicated pins 10
 - 2.6 Communication interface pins 10
 - 2.7 RF front-end pins 12
- 3 Package and packing information 13**
 - 3.1 ECOPACK® packages 13
 - 3.2 VFQFPN56 8 x 8 mm package information 13
- 4 Ordering information 15**
- 5 Revision history 16**

List of tables

Table 1.	Power supply pins	8
Table 2.	Main function pins	9
Table 3.	Test/emulated dedicated pins	10
Table 4.	Communication interface pins	10
Table 5.	RF front-end pins	12
Table 6.	VFQFPN56 package dimensions	13
Table 7.	Document revision history	16

List of figures

Figure 1.	STA8090GA system block diagram	6
Figure 2.	VFQFPN56 connection diagram (with CAN)	7
Figure 3.	VFQFPN56 connection diagram (without CAN)	8
Figure 4.	VFQFPN56 8 x 8 mm package dimension	14
Figure 5.	Ordering information scheme	15

1 Overview

STA8090GA is one of the part number of Teseo III STA8090x series.

STA8090GA is a highly integrated single-chip standalone GNSS receiver designed for positioning system applications.

STA8090GA embeds the new ST GNSS positioning engine capable of receiving signals from multiple satellite navigation systems, including the US GPS, European Galileo, Russia's GLONASS, Chinese BeiDou and Japan's QZSS.

The STA8090GA ability of tracking simultaneously the signals from multiple satellites regardless of their constellation, make this chip capable of delivering exceptional accuracy in urban canyons and in the environments where buildings and other obstructions make satellite visibility challenging.

The STA8090GA combines a high performance ARM946 microprocessor with I/O capabilities and enhanced peripherals. It supports USB2.0 standard at full speed (12 Mbps) with on-chip PHY.

The chip embeds backup logic with real time clock.

The device is offered with a complete firmware performing all positioning operations including acquisition, tracking, navigation and data output.

STA8090GA can be offered also bundled with STMicroelectronics dead reckoning firmware called TESEO-DRAW; TESEO-DRAW firmware is a multi-sensors data fusion hub for Teseo family IC's.

STA8090G embeds innovative power management with switching regulator for power consumption optimization.

The extended voltage supply range from 1.6 V to 4.3 V, the 1.8 V and 3.3 V I/O compliance support make the STA8090G the suitable solution for different user applications.

STA8090GA is compliant with ST Automotive Grade qualification which includes in addition to AEC-Q100 requirements a set of production flow methodologies targeting zero defect per million.

STA8090GA, fulfilling high quality and service level requirements of the Automotive market, is the ideal solution for in-dash navigation and OEM telematics applications.

The STA8090GA, using STMicroelectronics CMOSRF Technology, is housed in a VFQFPN56 wettable flank lead package with 8 x 8 x 1.0 mm body size and 0.5 mm pitch.

The wettable flanks package use makes easier the solder inspection process cutting down its cost.

2 Pin description

2.1 Block diagram

Figure 1. STA8090GA system block diagram

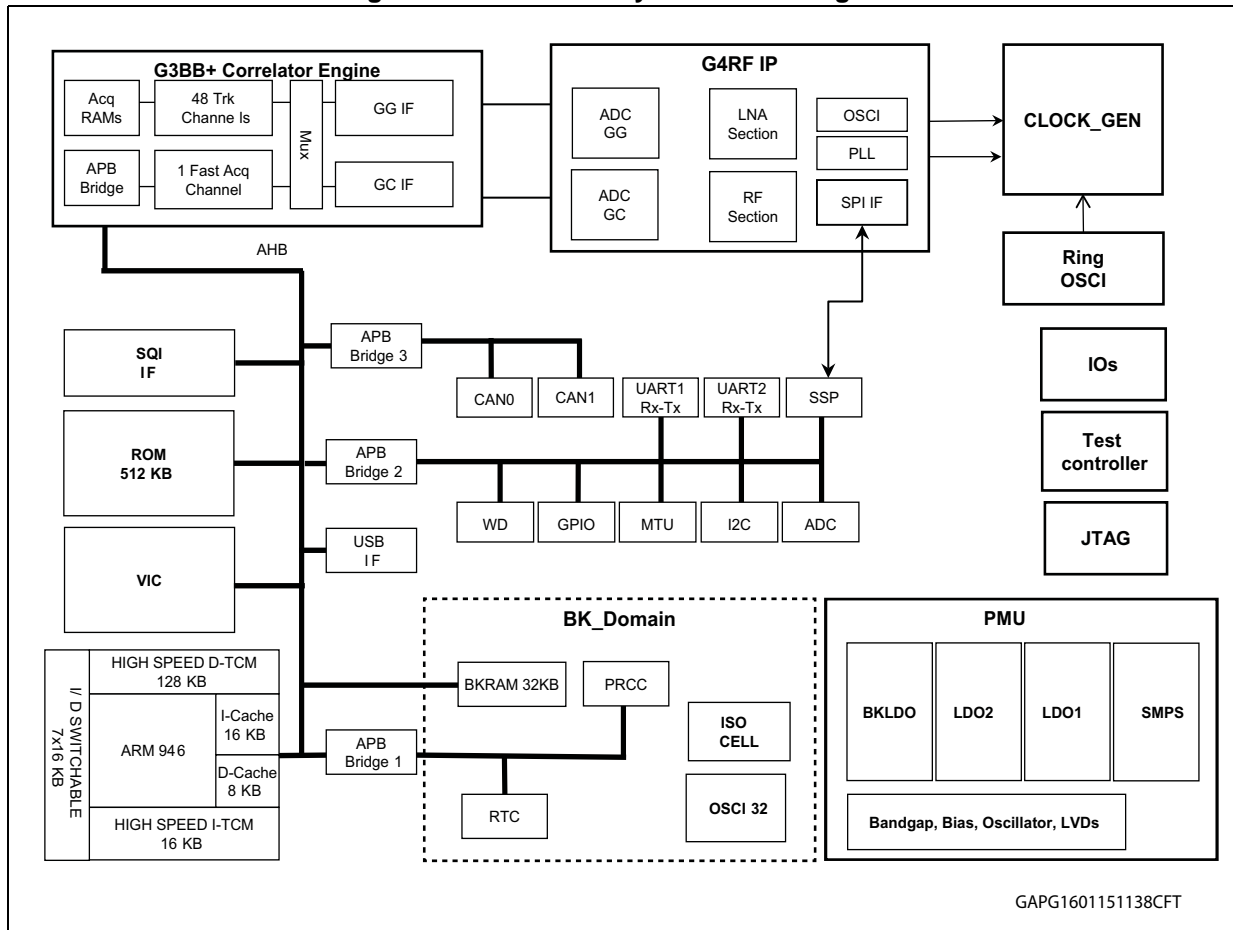

2.2 VFQFPN56 pin configuration

Figure 2. VFQFPN56 connection diagram (with CAN)

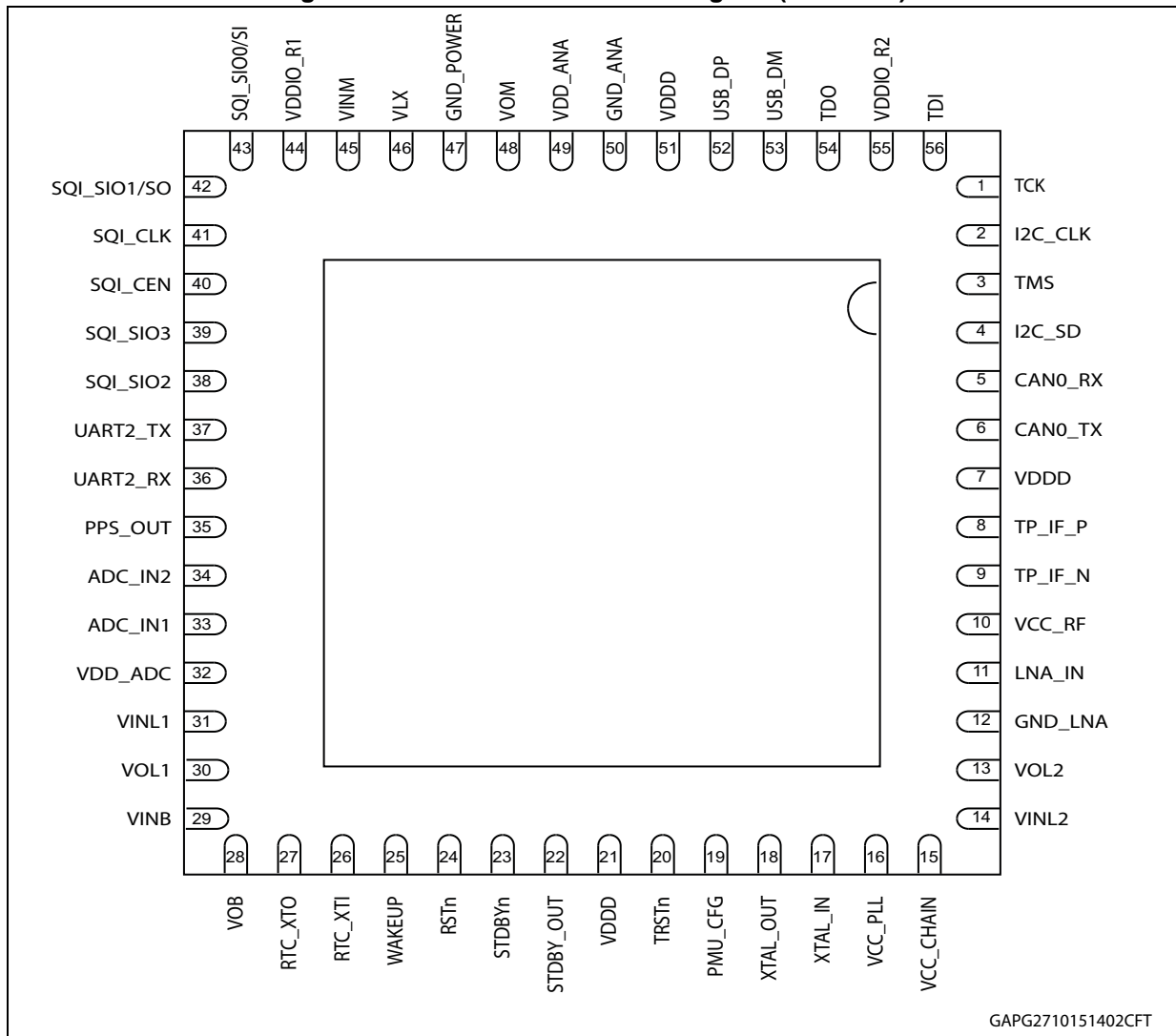
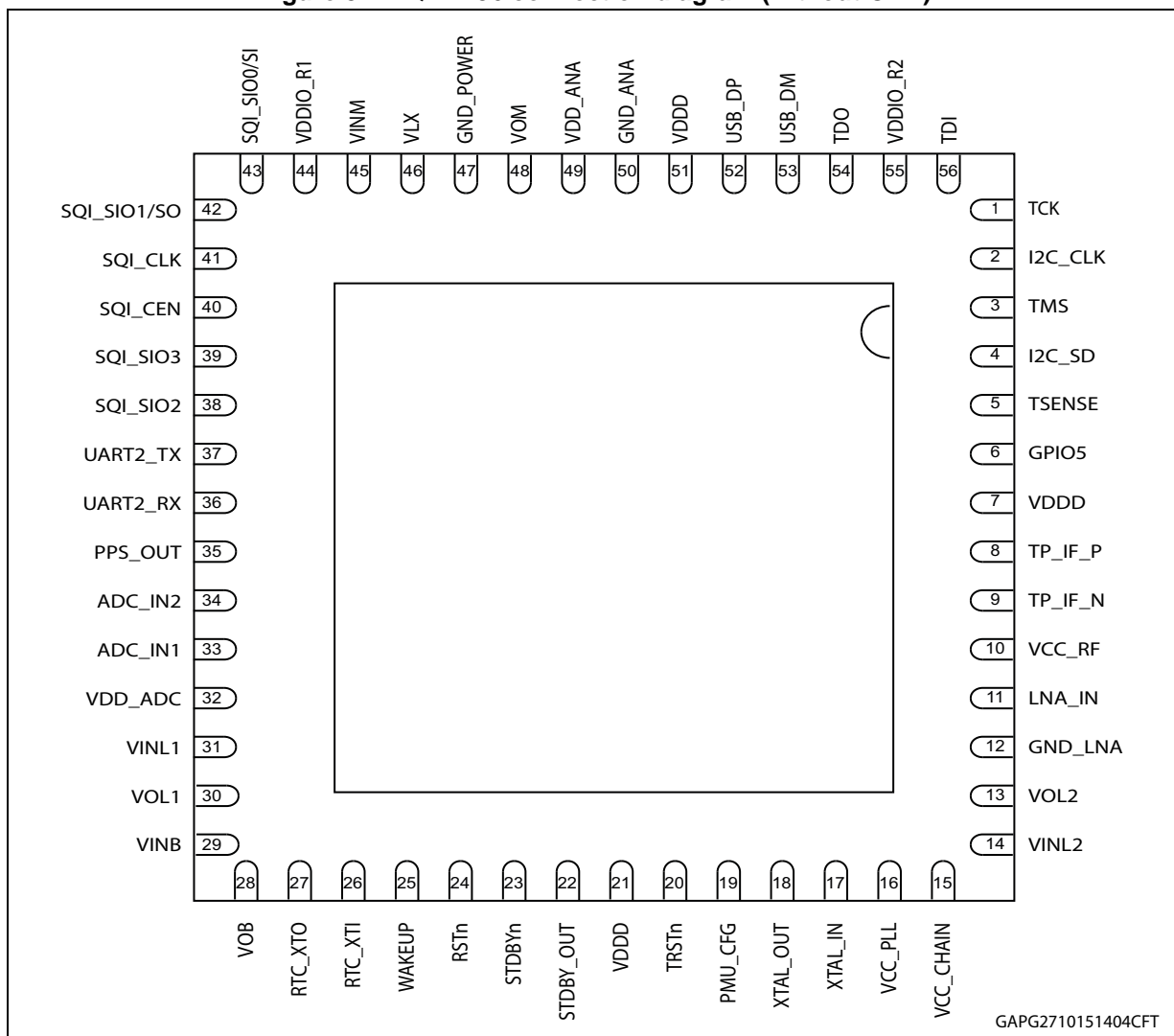

Figure 3. VFQFPN56 connection diagram (without CAN)



2.3 Power supply pins

Table 1. Power supply pins

Symbol	I/O voltage	I/O	Description	STA8090GA
VCC_CHAIN	1.2 V	PWR	Analog supply voltage for RF chain (1.2 V)	15
VCC_PLL	1.2 V	PWR	Analog supply voltage for PLL RF (1.2 V)	16
VCC_RF	1.2 V	PWR	Analog supply voltage for RF (1.2 V)	10
VDD_ADC	1.8 V	PWR	Digital supply voltage for ADC (1.8 V)	32
VDDD	1.2 V	PWR	Digital supply voltage	7, 21, 51
VDDIO_R1	1.8 V or 3.3 V	PWR	Digital supply voltage for I/O ring 1 (1.8 V or 3.3V)	44
VDDIO_R2	3.3 V	PWR	Digital supply voltage for I/O ring 2 (3.3 V)	55

Table 1. Power supply pins (continued)

Symbol	I/O voltage	I/O	Description	STA8090GA
VINB	1.6 V - 4.3 V	PWR	Backup LDO input supply voltage (1.6 V to 4.3 V)	29
VINL1	1.6 V - 4.3 V	PWR	LDO1 input supply voltage (1.6 V to 4.3 V)	31
VINL2	1.6 V - 4.3 V	PWR	LDO2 input supply voltage (1.6 V to 4.3 V)	14
VINM	1.6 V - 4.3 V	PWR	SMPS coil input supply (1.6 V to 4.3 V)	45
VDD_ANA	1.6 V - 4.3 V	PWR	SMPS input supply (1.6 V to 4.3 V)	49
VLX	0 V - 4.3 V	PWR	SMPS coil output	46
VOB	1.0 V	PWR	LDO backup output voltage (1.0 V)	28
VOL1	1.8 V	PWR	LDO1 output voltage (1.8 V)	30
VOL2	1.2 V	PWR	LDO2 output voltage (1.2 V)	13
VOM	1.1 V	PWR	SMPS output voltage (1.1 V; it can be also configured to 1.2 V)	48
GND_POWER	GND	GND	Ground	47
GND_ANA	GND	GND	Ground	50
GND_LNA	GND	GND	Ground	12

2.4 Main function pins

Table 2. Main function pins

Symbol	I/O voltage	I/O	Description	STA8090GA
ADC_IN1	1.4 V – 0 V typ range	I	ADC Analog input [1]	33
ADC_IN2	1.4 V – 0 V typ range	I	ADC Analog input [2]	34
RSTn	1.0 V	I	Reset Input with Schmitt-Trigger characteristics and noise filter.	24
RTC_XTI	1.0 V (max)	I	Input of the 32 KHz oscillator amplifier circuit and input of the internal real time clock circuit.	26
RTC_XTO	1.0 V (max)	O	Output of the oscillator amplifier circuit.	27
STDBY_OUT	1.0 V	O	When low, indicates the chip is in Standby mode	22
STDBYn	1.0 V	I	When low, the chip is forced in Standby Mode - All pins in high impedance except the ones powered by Backup supply	23
WAKEUP	1.0 V	I	WAKEUP from STANDBY mode	25
PMU_CFG	1.0 V	I	Power management unit config pin High -> VOL1 = 1.1 V, VOM = 1.8 V Low -> VOL1 = 1.8 V, VOM = 1.1 V	19

2.5 Test/emulated dedicated pins

Table 3. Test/emulated dedicated pins

Symbol	I/O voltage	I/O	Description	STA8090GA
TCK	VDDIO_R2	I	JTAG Test Clock	1
TDI	VDDIO_R2	I	JTAG Test Data In	56
TDO	VDDIO_R2	O	JTAG Test Data Out	54
TMS	VDDIO_R2	I	JTAG Test Mode Select	3
TRSTn	1.0 V	I	JTAG Test Circuit Reset	20
TP_IF_N	1.2 V	O	Diff.Test Point for IF – Neg.	9
TP_IF_P	1.2 V	O	Diff.Test Point for IF – Pos.	8

2.6 Communication interface pins

Table 4. Communication interface pins

Symbol	I/O voltage	I/O	Alternative function	Function	Description	STA8090GA
SQI_CLK	VDDIO_R1	O	AF2 (default)	SQI_CLK	SQI Flash clock	41
		—	AF0, AF1, AF3	Reserved	Reserved	
SQI_CEN	VDDIO_R1	O	AF2 (default)	SQI_CEN	SQI Flash chip enable	40
		—	AF0, AF1, AF3	Reserved	Reserved	
SQI_SIO0/SI	VDDIO_R1	I/O	AF2 (default)	SQI_SIO0/SI	SQI Flash data IO 0 / ser. I	43
		—	AF0, AF1, AF3	Reserved	Reserved	
SQI_SIO1/SO	VDDIO_R1	I/O	AF2 (default)	SQI_SIO1/SO	SQI Flash data IO 1 / ser. O/ BOOT2	42
		—	AF0, AF1, AF3	Reserved	Reserved	
SQI_SIO2	VDDIO_R1	I/O	AF2 (default)	SQI_SIO2	SQI Flash data IO 2	38
		—	AF0, AF1, AF3	Reserved	Reserved	
SQI_SIO3	VDDIO_R1	I/O	AF2 (default)	SQI_SIO3	SQI Flash data IO 3 / BOOT1	39
		—	AF0, AF1, AF3	Reserved	Reserved	

Table 4. Communication interface pins (continued)

Symbol	I/O voltage	I/O	Alternative function	Function	Description	STA8090GA
I2C_CLK	VDDIO_R2	O	AF0 (default)	I2C_CLK	I2C clock	2
		I/O	AF1	GPIO8	General purpose I/O #8	
		O	AF2	CAN1_TX ⁽¹⁾	CAN1 transmit data output	
		—	AF3	Reserved	Reserved	
I2C_SD	VDDIO_R2	—	AF0 (default)	Reserved	Reserved	4
		O	AF1	MSP_CLK	MSP serial clock output	
		I/O	AF2	I2C_SD	I2C serial data	
		I/O	AF3	GPIO20	General purpose I/O #20	
CAN0_TX ⁽¹⁾	VDDIO_R2	—	AF0 (default)	Reserved	Reserved	6
		O	AF1	MSP_DO	MSP serial clock output	
		O	AF2	CAN0_TX ⁽¹⁾	CAN0 transmit data output	
		I/O	AF3	GPIO5	General purpose I/O #5	
CAN0_RX ⁽¹⁾	VDDIO_R2	—	AF0 (default)	Reserved	Reserved	5
		O	AF1	MSP_FS	MSP left/right clock output	
		I	AF2	CAN0_RX	CAN0 receive data input / BOOT3	
		I/O	AF3	T _{SENSE}	External temperature capture port	
UART2_RX	VDDIO_R1	I	AF0 (default)	UART2_RX	UART2 Rx data	36
		I/O	AF1	GPIO28	General purpose I/O #28	
		I/O	AF2	I2C_SD	I2C serial data	
		—	AF3	Reserved	Reserved	
UART2_TX	VDDIO_R1	O	AF0 (default)	UART2_TX	UART2 Tx data / BOOT0	37
		I/O	AF1	GPIO29	General purpose I/O #29	
		O	AF2	I2C_CLK	I2C clock	
		—	AF3	Reserved	Reserved	
USB_DM	VDDIO_R2	USB	AF0	USB_DM	USB D- signal	53
		I	AF1 (default)	UART1_RX	UART1 Rx data	
		I	AF2	CAN1_RX ⁽¹⁾	CAN1 receive data input	
		I/O	AF3	I2C_SD	I2C serial data	
USB_DP	VDDIO_R2	USB	AF0	USB_DP	USB D+ signal	52
		O	AF1 (default)	UART1_TX	UART1 Tx data	
		O	AF2	CAN1_TX ⁽¹⁾	CAN1 transmit data output	
		O	AF3	I2C_CLK	I2C clock	

Table 4. Communication interface pins (continued)

Symbol	I/O voltage	I/O	Alternative function	Function	Description	STA8090GA
PPS_OUT	VDDIO_R1	I/O	AF0 (default)	GPIO1	General purpose I/O #1	35
		I	AF1	MSP_DI	MSP serial data input	
		O	AF2	PPS_OUT	Pulse per second output	
		I/O	AF3	T _{SENSE}	External temperature capture port	

1. Only for STA8090GA.

2.7 RF front-end pins

Table 5. RF front-end pins

Symbol	I/O voltage	I/O	Description	STA8090GA
LNA_IN	1.2V	I	Low Noise Amplifier Input	11
XTAL_IN	1.2V	I	Input Side of Crystal Oscillator or TCXO Input	17
XTAL_OUT	1.2V	O	Output Side of Crystal Oscillator	18

3 Package and packing information

3.1 ECOPACK[®] packages

In order to meet environmental requirements, ST offers these devices in different grades of ECOPACK[®] packages, depending on their level of environmental compliance. ECOPACK[®] specifications, grade definitions and product status are available at: www.st.com.

ECOPACK[®] is an ST trademark.

3.2 VFQFPN56 8 x 8 mm package information

Table 6. VFQFPN56 package dimensions

Symbol	Min.	Typ.	Max
Common dimensions			
A	0.80	0.85	0.90
A1	0.00	0.01	0.05
A2	0.60	0.65	0.70
A3	0.20 REF		
Θ	0		12°
P	0.24	0.42	0.60
e	0.50 BSC		
N		56	
L	0.30	0.40	0.50
L1	0.05	0.15	0.25
L2	0.05	0.10	0.15
b	0.20	0.25	0.30
b1	0.10	0.15	0.20

Figure 4. VFQFPN56 8 x 8 mm package dimension

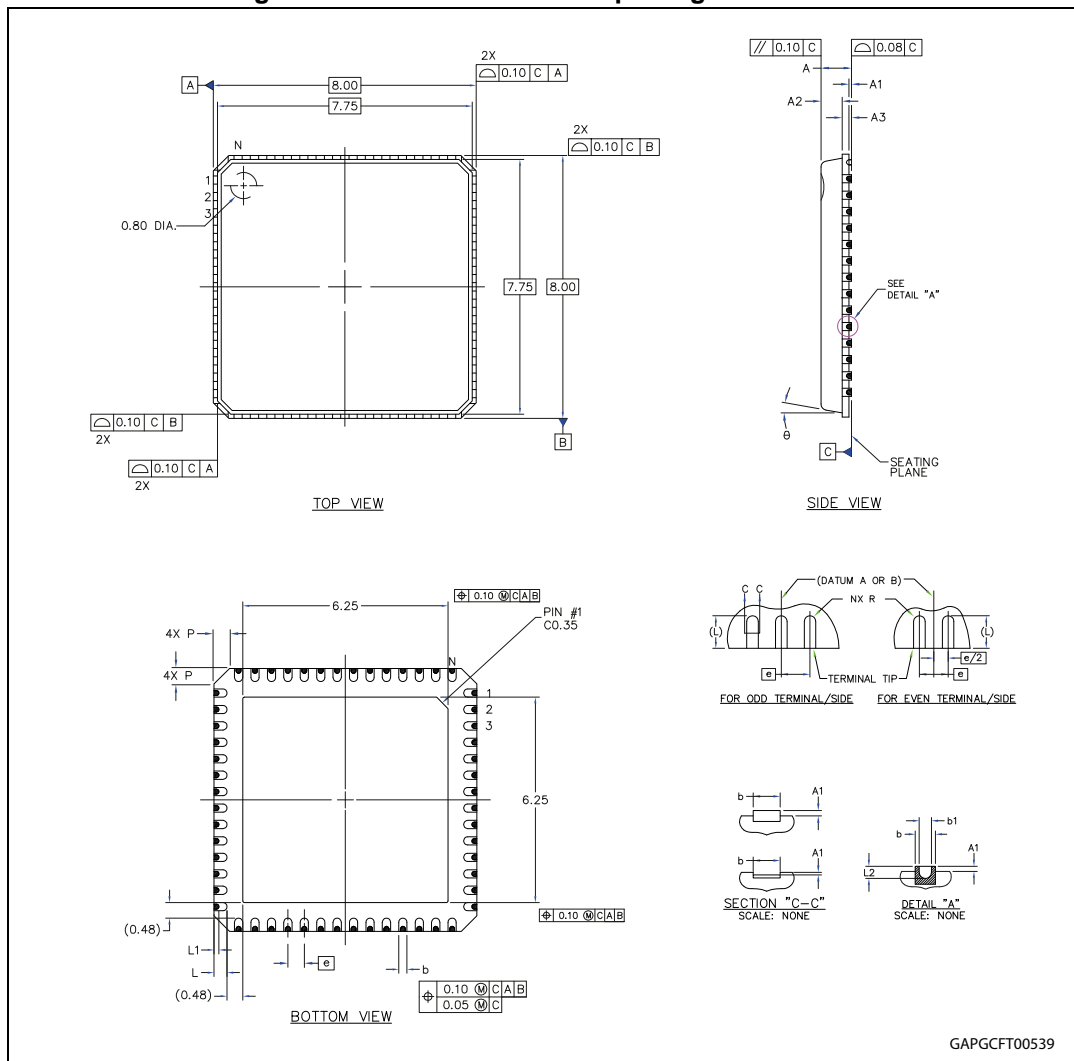

GAPGCF00539

4 Ordering information

Figure 5. Ordering information scheme

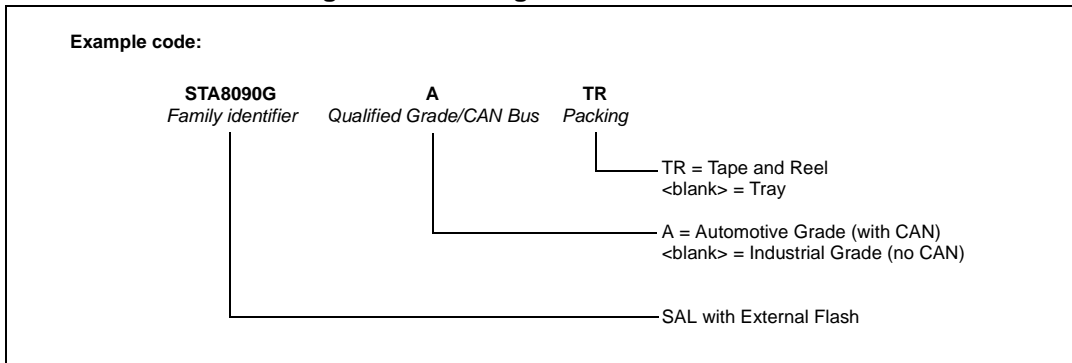

5 Revision history

Table 7. Document revision history

Date	Revision	Changes
17-Dec-2015	1	Initial release.
11-Jan-2016	2	<i>Figure 3: VFQFPN56 connection diagram (without CAN)</i> – Pin 5 and pin 6: updated name

IMPORTANT NOTICE – PLEASE READ CAREFULLY

STMicroelectronics NV and its subsidiaries ("ST") reserve the right to make changes, corrections, enhancements, modifications, and improvements to ST products and/or to this document at any time without notice. Purchasers should obtain the latest relevant information on ST products before placing orders. ST products are sold pursuant to ST's terms and conditions of sale in place at the time of order acknowledgement.

Purchasers are solely responsible for the choice, selection, and use of ST products and ST assumes no liability for application assistance or the design of Purchasers' products.

No license, express or implied, to any intellectual property right is granted by ST herein.

Resale of ST products with provisions different from the information set forth herein shall void any warranty granted by ST for such product.

ST and the ST logo are trademarks of ST. All other product or service names are the property of their respective owners.

Information in this document supersedes and replaces information previously supplied in any prior versions of this document.

© 2016 STMicroelectronics – All rights reserved

