

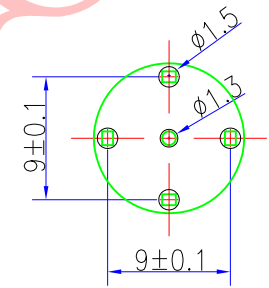

Product NO.		DOSIN-801-0209		
REV	DESCRIPTION	DWN	DATE	APPROVEN
A	First issue	JIM	2012/11/02	John kine

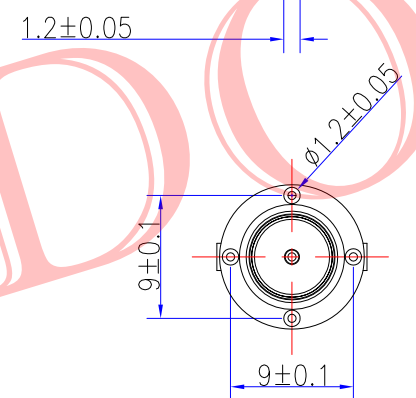
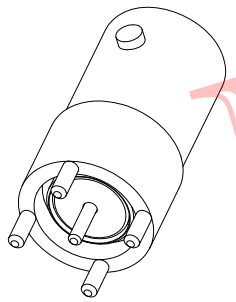
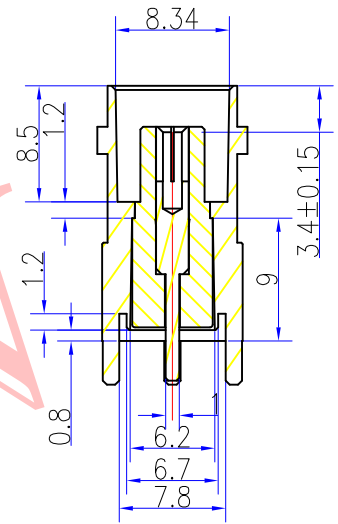
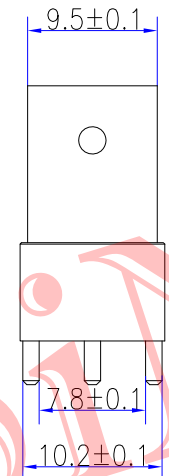
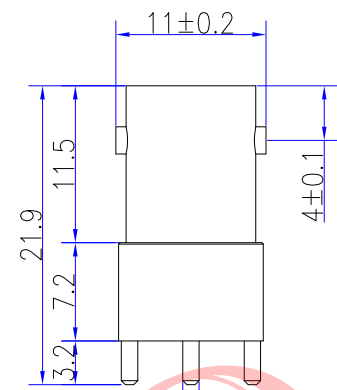
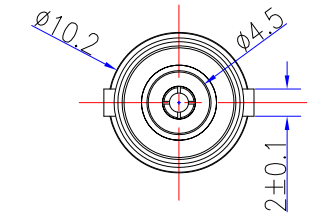
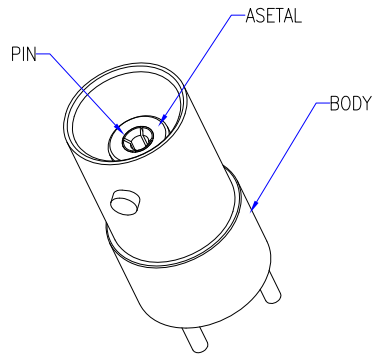

SECTION
A-A

Specifications

Impedance: 50 Ohms
 Frequency Range: DC~3G
 VSWR: 1.3MAX
 Working Voltage: 500V rms @ sea level
 Insulation Resistance: 5000 Ohms min
 Temperature Range: -55°C TO +155°C
 Relative Temperature: ≤95% (40° C ± 2° C)
 Drawings products are in line with ROHS standards

NOTE:		Tolerance	0-6	±0.15
DRAWN Zelin. Zhang			6-30	±0.20
2012/11/10		View	30-120	±0.5
CHECKED			Angular	±2°
APPROVALS John		UNIT	MM	
12/04.2012		SCALE	1:1	

Dosin Industrial(H.K)Co.Ltd 东莞市德索五金电子制品有限公司 Dosin Hardware Electronics Co.,Ltd		E-mail: dosin2005@163.com dosin2005@dosin-china.com Web: http://www.dosinconn.com TEL: (0086) 769-81153906 FAX: (0086) 769-81875836	
Name: BNC CONNECTOR DNN			
SIZE A	Product NO. DOSIN-801-0209		REV B
Date time 2012/11/02		CAD FILE D/company drawings/BD	SHEET: 1 OF 1

C	INSULATOR	POM	NONE	1
B	CONTACT	BRASS	GOLD	1
A	BODY	ZINC	NICKEL	1
NO	DESCRIPTION	MATERIAL	FINISHED	QTY