

1 2 3 4

A

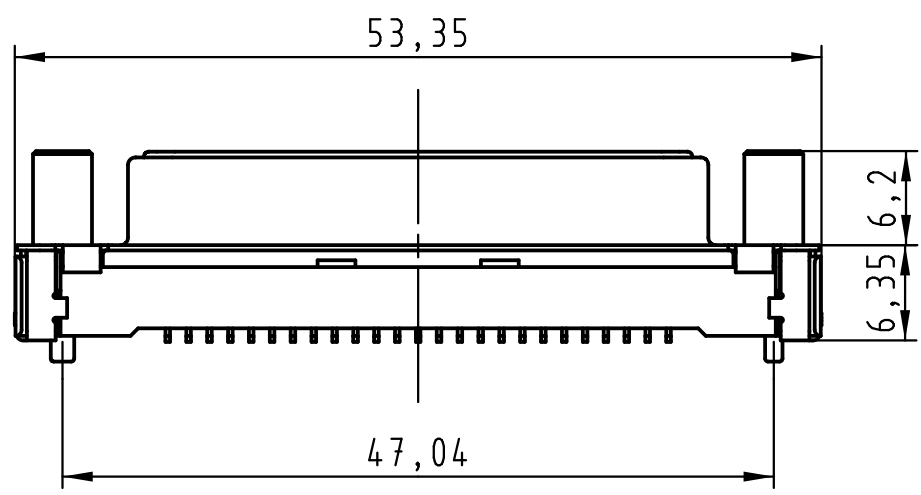

B

Mating face according to CECC 75301-802

No. 1 contact

Screw lock

C

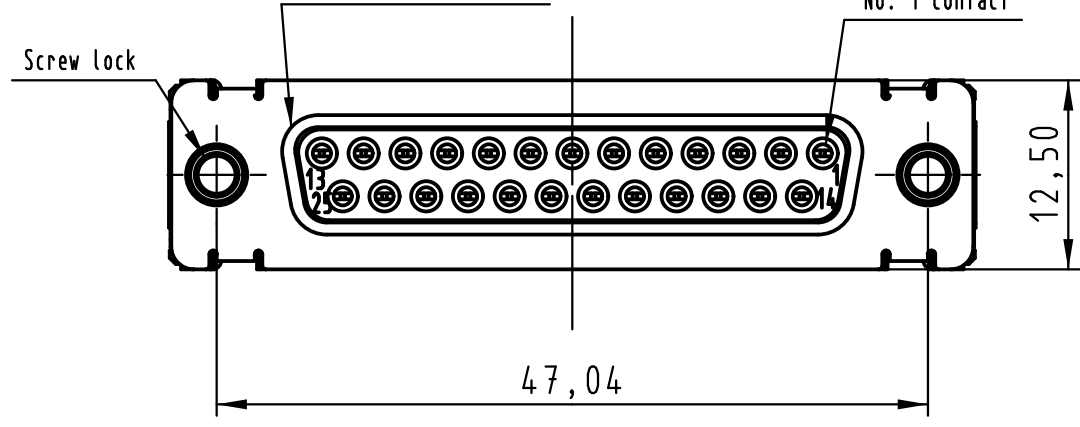

All rights reserved

D

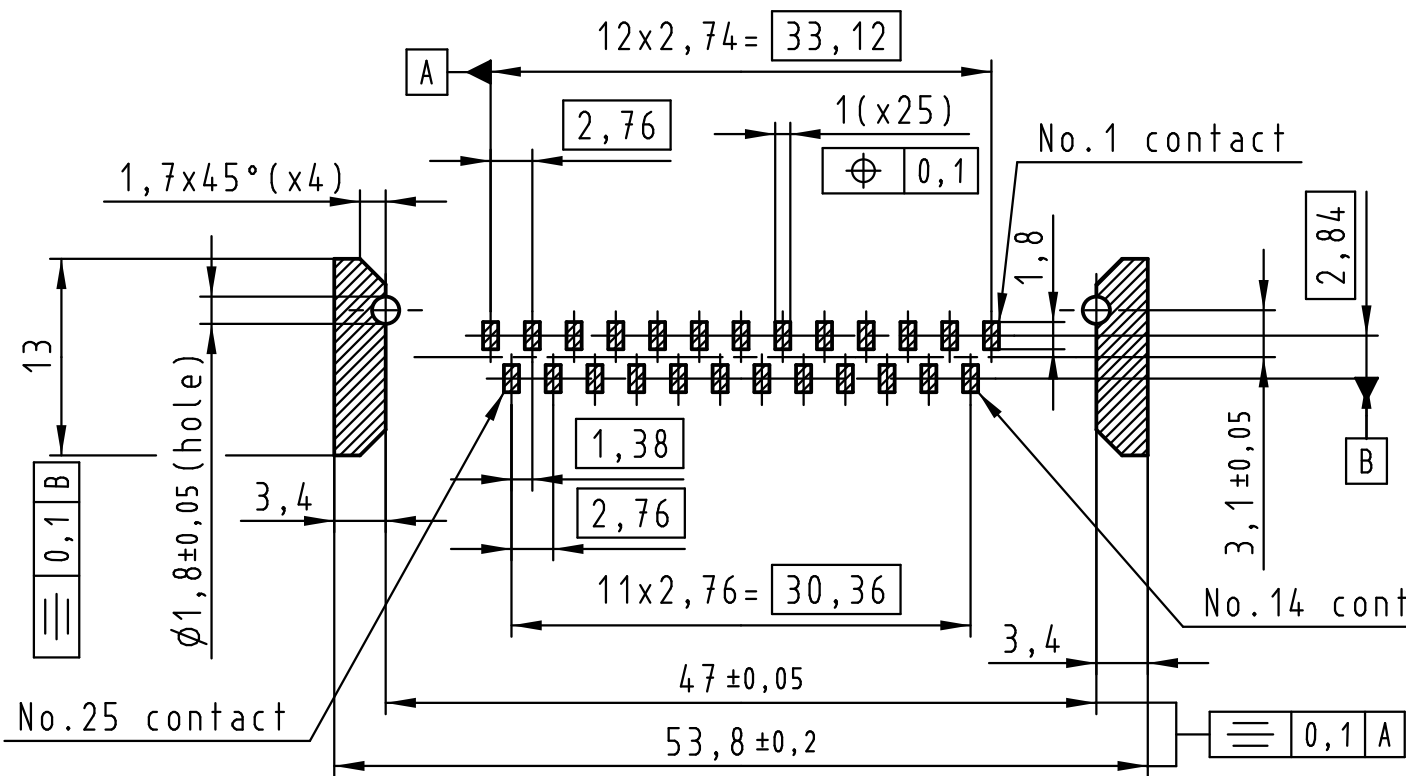

E

F

PCB layout, component side

1 2 3 4

1 2 3 4

A

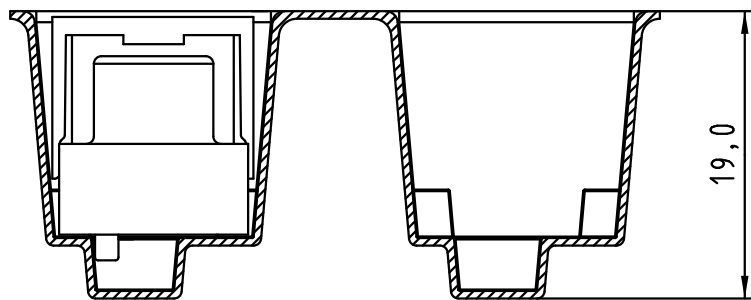

Detail A

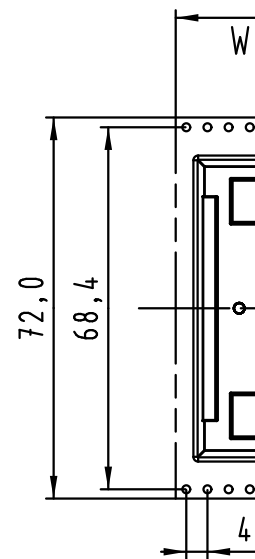

B

C

All rights reserved

D

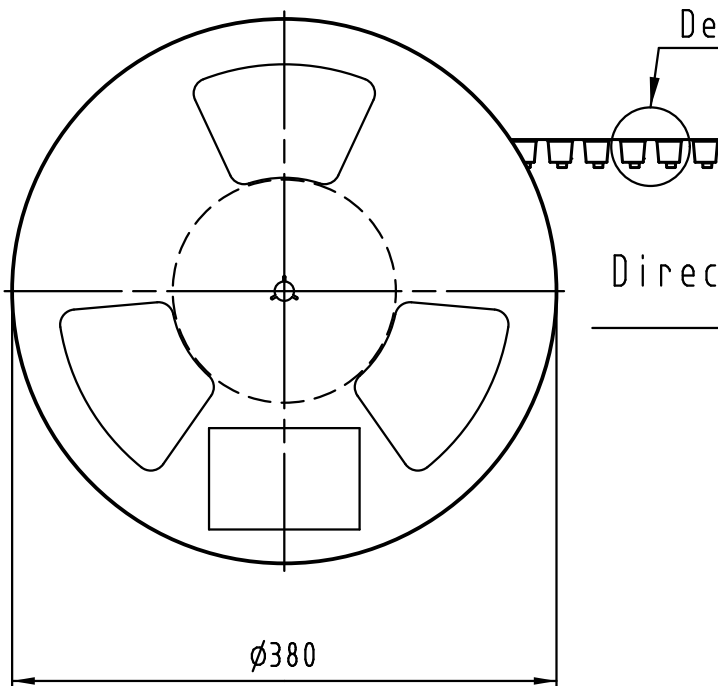

Detail A

Direction of unreeling

E

F

0955 315 3621 741	1	M3	Black insulator	Reel Packaging: 140 connectors
0955 315 3622 741	1	4-40 UNC		
0955 315 6621 741	2	M3		
0955 315 6622 741	2	4-40 UNC		
0955 315 7621 741	3	M3		
0955 315 7622 741	3	4-40 UNC		
Part number	PL	Screw lock	Index designation	

1 2 3 4