

Gateway PB2 Features

Sure Cross® Performance embeddable board modules provide connectivity where traditional wired connections are not possible or are cost-prohibitive. Wireless networks are formed around a Gateway, which acts as the wireless network master device, and one or more Nodes. Sure Cross Performance embeddable board modules communicate with all Sure Cross Performance radios.



- Wireless industrial I/O device with two PNP discrete inputs, two PNP discrete outputs, two 0–20 mA analog inputs, and two 0–20 mA analog outputs
- Selectable transmit power levels of 250 mW or 1 Watt for 900 MHz models and 65 mW for 2.4 GHz models
- 10 V DC to 30 V DC power input
- DIP switches for user configuration
- Modbus serial interface
- Frequency Hopping Spread Spectrum (FHSS) technology ensures reliable data delivery
- Transceivers provide bidirectional communication between the Gateway and Node, including fully acknowledged data transmission
- Lost RF links are detected and relevant outputs set to user-defined conditions

Refer to document number [164886](#), packed with your PB2 Gateway, for a quick start guide to forming PB2 to PB2 networks.

Models

Models	Frequency	Inputs and Outputs
DX80G2M6S-PB2	2.4 GHz ISM Band	Inputs: Two PNP discrete, two 0–20 mA analog Outputs: Two PNP discrete, two 0–20 mA analog
DX80G9M6S-PB2	900 MHz ISM Band	Automatically maps I/O from a Node to the Gateway via DIP switches on the Gateway

Configuration Instructions

Mixing Performance and Non-Performance (150 mW) Radios in the Same Network

To comply with federal regulations, the 150 mW radios and 1 Watt radios communicate differently. All Performance models offer the ability to select between 250 mW and 1 Watt operation using the DIP switches.

To mix Performance radios with non-Performance radios, refer to the product datasheet and:

- Operate Performance radios in 250 mW mode, not 1 Watt mode
- Set non-Performance (150 mW) radios to use Extended Address Mode

The 150 mW, 250 mW, and 1 Watt networks operate when collocated, but verify the antenna separation distance between a Gateway and Node or between two Gateways is at least 10 feet apart. For more detailed instructions about setting up your wireless network, refer to the following documents:

- DX80 Performance Quick Start Guide (p/n [128185](#))
- DX80 Performance Wireless I/O Network Instruction Manual (p/n [132607](#))
- DXM Quick Start Guide (p/n [191247](#))
- DXM Instruction Manuals (DXM100-Bx: [190037](#) and DXM150-Bx: [190038](#))

Setting Up Your Wireless Network

To set up and install your wireless network, follow these steps.

For complete instructions, including binding, configuration, installation, weatherproofing, device menu maps, troubleshooting, and a list of accessories, refer to Sure Cross® Wireless I/O Network Instruction Manual (p/n [132607](#))

1. Disconnect the power from your Sure Cross® devices.
2. Configure the DIP switches of all devices. DIP switch configurations are always listed in the product's datasheet.
3. If your device has I/O, connect the sensors to the Sure Cross devices. Available I/O is always listed in the product's datasheet. If your device does not have I/O, skip this step.

4. Refer to the wiring diagrams to apply power to all devices.
 - For housed models, the Gateway's LED 1 is solid green and the Node's LED 2 flashes red to indicate there is no radio link to the Gateway.
 - For board-level models, the Gateway's LED is solid green and the Node's LED flashes red to indicate there is no radio link to the Gateway.
5. Form the wireless network by binding the Nodes to the Gateway.
6. Observe the LED behavior to verify the devices are communicating with each other.
 - For housed models, the Gateway's LED 1 is solid green and the Node's LED 1 flashes green to indicate it is communicating with the Gateway.
 - For board-level models, the Gateway's LED is solid green and the Node's LED flashes green to indicate it is communicating with the Gateway.
7. Configure any I/O points to use the sensors connected to the Sure Cross devices.
8. Conduct a site survey between the Gateway and Nodes.
9. Install your wireless sensor network components.

Configure the DIP Switches

Before changing DIP switch positions, disconnect the power⁽¹⁾. Any changes made to the DIP switches are not recognized until after power is cycled to the device. For parameters not set using the DIP switches, use the configuration software to make configuration changes. For parameters set using the DIP switches, the DIP switch positions override any changes made using the configuration software.

DIP Switch Settings

Transmit Power

The 900 MHz radios transmit at 1 Watt (30 dBm) or 250 mW (24 dBm). The 250 mW mode reduces the radio's range but improves the battery life in short-range applications. For 2.4 GHz models, this DIP switch is disabled. The transmit power for 2.4 GHz is fixed at about 65 mW EIRP (18 dBm).

DIP Switch 1	
OFF *	1 Watt (30 dBm, 900 MHz models only)
ON	250 mW (24 dBm, 900 MHz models only), DX80 compatibility mode

Modbus/Software Configured or DIP Switch Configured

In Modbus/Software Configured mode, use the DX80 Performance Configuration Software or a Modbus command to change the device parameters. DIP switch positions 3 through 8 are ignored. In DIP Switch Configured mode, use the DIP switches to configure the parameters listed in the table. By default, this Gateway uses Modbus commands or the DX80 Performance Configuration Software to configure the device.

DIP Switch 2	
OFF *	Modbus or software configured (DIP switches 3-8 are ignored)
ON	DIP switch configured

DIP Switch 3

DIP switch 3 must remain in the OFF position.

Link Loss Output State

The Sure Cross® wireless devices use a deterministic radio link time-out method to address RF link interruption or failure. When a radio link fails, all pertinent wired outputs are set to defined states until the link is recovered, ensuring that disruptions in the communications link result in predictable system behavior. Select the state the outputs are changed to during a link loss.

DIP Switches		
4	5	
OFF *	OFF *	Off (discrete) or 0 mA (analog)
OFF	ON	On (discrete) or 20 mA (analog)
ON	OFF	Hold last stable state
ON	ON	Reserved

⁽¹⁾ For devices powered by batteries integrated into the housing, triple-click button 2, then double-click button 2 to reset the device without removing the battery.

* Default configuration

Analog Scale

Use the DIP switch to select which current scale to use for all the device's analog inputs and outputs: 0 to 20 mA or 4 to 20 mA. When using a 4-20 mA sensor with a 0-20 mA input, the sensor uses the 4-20 mA section of the total range. Using a 4-20 mA with a 0-20 mA input allows you to determine when you have an error condition with the sensor. A normal input reading between 4 and 20 mA indicates a functioning sensor whereas a value below 4 mA indicates an error condition, such as a broken wire or loose connection. This DIP switch is used only on the 0 to 20 mA models, not the 0 to 10V models.

DIP Switch 6	
OFF *	0–20 mA scale
ON	4–20 mA scale

* Default configuration

I/O Mapping

When using these DIP switches to set the I/O mapping, you must change the Node's rotary dials to 01 or 02, depending on which mapping sequence you are using. By default, the Nodes ship from the factory set to 11.

		DIP Switches	
		7 = OFF	8 = OFF
		No I/O mapping via the DIP switches. Use the DX80 Performance Configuration Software to configure the I/O.	

One PB2 Node to a PB2 Gateway		DIP Switches	
		7 = OFF	8 = ON
		Node 01 Discrete IN 1 → Gateway Discrete OUT 1 Node 01 Discrete IN 2 → Gateway Discrete OUT 2 Node 01 Analog IN 1 → Gateway Analog OUT 1 Node 01 Analog IN 2 → Gateway Analog OUT 2 Gateway Discrete IN 1 → Node 01 Discrete OUT 1 Gateway Discrete IN 2 → Node 01 Discrete OUT 2 Gateway Analog IN 1 → Node 01 Analog OUT 1 Gateway Analog IN 2 → Node 01 Analog OUT 2	

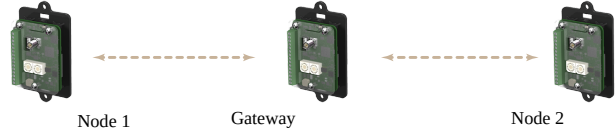
Two PB2 Nodes to a PB2 Gateway		DIP Switches	
		7 = ON	8 = OFF
		Node 01 Discrete IN 1 → Gateway Discrete OUT 1 Node 02 Discrete IN 1 → Gateway Discrete OUT 2 Node 01 Analog IN 1 → Gateway Analog OUT 1 Node 02 Analog IN 1 → Gateway Analog OUT 2 Gateway Discrete IN 1 → Node 01 Discrete OUT 1 Gateway Discrete IN 2 → Node 02 Discrete OUT 1 Gateway Analog IN 1 → Node 01 Analog OUT 1 Gateway Analog IN 2 → Node 02 Analog OUT 1	

Wire the IO and Apply Power for the PB2

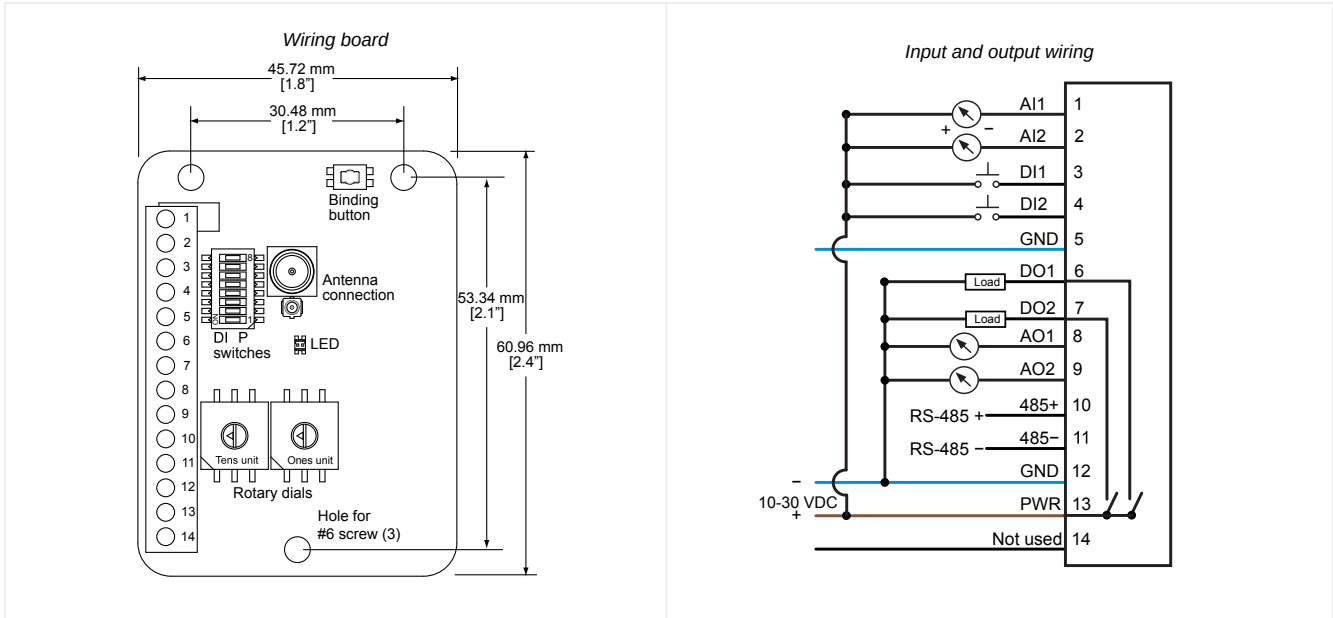

Pin	Description	Label	Pin	Description	Label
1	Analog IN 1 (0 to 20 mA)	AI1	8	Analog OUT 1 (0 to 20 mA)	AO1
2	Analog IN 2 (0 to 20 mA)	AI2	9	Analog OUT 2 (0 to 20 mA)	AO2
3	Discrete IN 1 (PNP)	DI1	10	RS-485 + Host communication connection	485+
4	Discrete IN 2 (PNP)	DI2	11	RS-485 - Host communication connection	485-
5	Ground ⁽¹⁾	GND	12	Ground	GND
6	Discrete OUT 1 (PNP)	DO1	13	10 to 30 V DC	PWR
7	Discrete OUT 2 (PNP)	DO2	14	Not used	-

Bind Radios to Form Networks with Gateway Board Modules

Binding Nodes to a Gateway ensures the Nodes only exchange data with the Gateway they are bound to. For a more detailed definition of binding mode, refer to the *Sure Cross DX80 Performance Wireless I/O Networks* instruction manual (p/n [132607](#)).

Apply power to the board module Gateway and all Nodes.

NOTE: If you are binding a Gateway board module to a Wireless Q45 Sensor, refer to the binding instructions in the Wireless Q45 Sensor's datasheet.

1. Enter binding mode on the Gateway by triple-clicking the binding button.
The green and red LED flashes. Any Node entering binding mode will bind to this Gateway.
2. Enter binding mode on the Node.
 - If you have a two-button Node, triple-click button 2.
 - If you have a one-button (board module) Node, triple-click the binding button.

⁽¹⁾ The three ground connections are tied together internally.



The Node enters binding mode and locates the Gateway in binding mode.

- For two LED models, the red LEDs flash alternately. After binding is complete, both LEDs are both solid red for a few seconds.
 - For one-LED models, the red and green LED flashes alternately while the Node searches for the Gateway. After binding is complete, the LED is red and green for four seconds (looks amber), then the red and green flash simultaneously (looks amber) four times.
 - The Node automatically exits binding mode, cycles its power, then enters RUN mode.
3. Use the Node's rotary dials to assign a valid decimal Node Address (between 01 and 47). The left rotary dial represents the tens digit (0 through 4) and the right dial represents the ones digit (0 through 9) of the Node Address.
 4. Repeat steps 2 and 3 for all Nodes that will communicate to this Gateway.
 5. Exit binding mode on the Gateway by single-clicking the binding button.

LED Behavior for the Gateways

Verify all devices are communicating properly. The radios and antennas must be a minimum distance apart to function properly.

Recommended minimum distances are:

900 MHz 150 mW and 250 mW radios: 6 feet

900 MHz 1 Watt radios: 15 feet

2.4 GHz 65 mW radios: 1 foot

LED (Bi-color)	Gateway Status
Solid green	Power ON
Green and red flashing alternately	Binding mode
Flashing red	Device Error
Green and red flashing together, looks amber	Modbus Communication Active
Flashing red	Modbus Communication Error
Solid red	Gateway is trying to conduct a Site Survey with a Node that doesn't exist
Green and red solid together, looks amber)	No radio communication detected

For Gateway and Ethernet Bridge systems, active Modbus communication refers to the communication between the Gateway and the Ethernet Bridge. For Gateway-only systems, the Modbus communication LEDs refer to the communication between the Gateway and its host system (if applicable).

Conduct a Site Survey from a Gateway Board Model

Conducting a Site Survey, also known as an RSSI (Radio Signal Strength Indication), analyzes the radio communications link between the Gateway and any Node within the network by analyzing the radio signal strength of received data packets and reporting the number of missed packets that required a retry.

Perform a Site Survey before permanently installing the radio network to ensure reliable communication. Only the Gateway can initiate a Site Survey, and the Site Survey analyzes the radio communications link with one Node at a time. Follow these steps to conduct a Site Survey from the board module Gateway.

1. Set the Gateway's rotary dials to the Node address you'd like to conduct a Site Survey with.

For example, to analyze the signal strength between this Gateway and Node 02, rotate the left rotary dial to 0 and the right rotary dial to 2.

The Site Survey automatically begins running. If there is no device at address 02, the LED is solid red. If there is a device at address 02, the LED flashes amber.
2. Evaluate the signal strength. The amber LED flashes at specific rates to indicate the Site Survey results. Each signal strength represents the majority of the data packets being received at that signal strength. For example, a strong signal strength indicates the majority of the data packets were received at a strong signal, but a few may have been received at a good or weak signal strength.

- Eight flashes per second: Very strong signal strength
 - Four flashes per second: Strong signal strength
 - Two flashes per second: Good signal strength
 - One flash per second: Weak signal strength
 - Solid amber LED: No radio communication detected
3. To exit the Site Survey, set the Gateway's rotary dials to 00. Otherwise, after 15 minutes the Gateway automatically exits Site Survey mode.
The LED flashes green to indicate the Gateway is in standard operating mode.

DX80 Performance Configuration Software

The configuration software offers an easy way to link I/O points in your wireless network, view I/O register values, and set system communication parameters when a host system is not part of the wireless network. The software runs on any computer with the Windows Vista, Windows 7, Windows 8, or Windows 10 operating system.

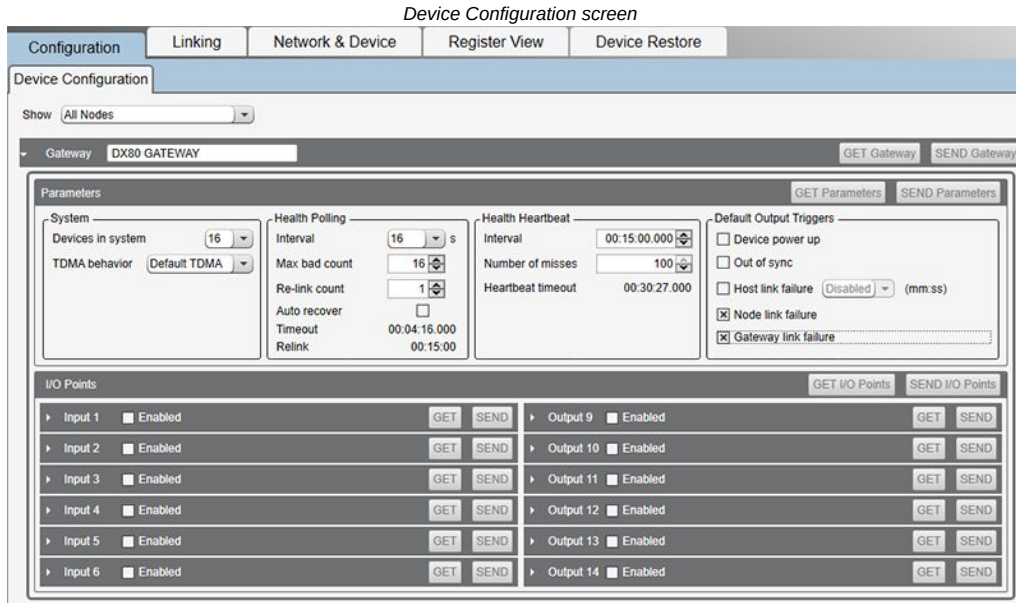

Use a USB to RS-485 adapter cable to connect a standalone DX80 Gateway to the computer. For DXM Controllers with an internal DX80 radio, connect a computer to the DXM Controller using the supplied USB or Ethernet connection. Download the most recent revisions of the configuration software from Banner Engineering's website: <https://www.bannerengineering.com/us/en/products/wireless-sensor-networks/reference-library/software.html>.

The USB to RS-485 adapter cable is not required for the DXM Controller. For standalone DX80 Gateway devices use:

- USB to RS-485 adapter cable model **BWA-UCT-900** for 1 Watt radios
- USB to RS-485 adapter cable model **BWA-HW-006** for all other radios

Installing the Board Modules

Sure Cross® board modules must be mounted inside a panel or OEM enclosure.

Holding Registers

Modbus Registers		EIP Registers		I/O Type	I/O Range		Holding Register Representation (Dec)	
Gateway	Node	Node			Min.	Max.	Min.	Max.
1	1 + (Node# × 16)	0 + (Node# × 8)	Instance 100 / N7	Discrete IN 1	0	1	0	1
2	2 + (Node# × 16)	1 + (Node# × 8)		Discrete IN 2	0	1	0	1
3	3 + (Node# × 16)	2 + (Node# × 8)		Analog IN 1 (mA)	0.0	20.0	0	65535
4	4 + (Node# × 16)	3 + (Node# × 8)		Analog IN 2 (mA)	0.0	20.0	0	65535
...		Reserved				
7	7 + (Node# × 16)	6 + (Node# × 8)		Device Message				
8	8 + (Node# × 16)	7 + (Node# × 8)						

Continued on page 7

Continued from page 6

Modbus Registers		EIP Registers		I/O Type	I/O Range		Holding Register Representation (Dec)	
Gateway	Node	Node			Min.	Max.	Min.	Max.
9	9 + (Node# × 16)	0 + (Node# × 8)	Instance 112 / N14	Discrete OUT 1	0	1	0	1
10	10 + (Node# × 16)	1 + (Node# × 8)		Discrete OUT 2	0	1	0	1
11	11 + (Node# × 16)	2 + (Node# × 8)		Analog OUT 1 (mA)	0.0	20.0	0	65535
12	12 + (Node# × 16)	3 + (Node# × 8)		Analog OUT 2 (mA)	0.0	20.0	0	65535
...						
15	15 + (Node# × 16)	6 + (Node# × 8)		Control Message				
16	16 + (Node# × 16)	7 + (Node# × 8)		Reserved				

Discrete Bit-Packed Registers

Discrete bit-packed registers include the discrete status registers, discrete inputs, and discrete outputs.

Bit packing involves using a single register, or range of contiguous registers, to represent I/O values.

When networks use similar Nodes to gather data using the same I/O registers for each Node, discrete data from multiple Nodes can be bit packed into a single register on the Gateway. The bit-packed data is arranged by I/O point starting at Modbus register 6601. For example, Discrete IN 1 for all the Nodes in the network is stored in three contiguous 16-bit registers.

The most efficient way to read (or write) discrete data from a Sure Cross® DX80 Gateway is by using these bit-packed registers because users can read or write registers for all devices using one Modbus message. The following registers contain discrete bit-packed I/O values for the Gateway and all Nodes. Values are stored first for the Gateway, then for each Node in order of Node address.

Discrete bit-packed register addresses and bit positions

Bit-Packed Device Status Registers

Register Address	Bit Position															
	15	14	13	12	11	10	9	8	7	6	5	4	3	2	1	0
6601	Node 15	Node 14	Node 13	Node 12	Node 11	Node 10	Node 9	Node 8	Node 7	Node 6	Node 5	Node 4	Node 3	Node 2	Node 1	Gateway
6602	Node 31	Node 30	Node 29	Node 28	Node 27	Node 26	Node 25	Node 24	Node 23	Node 22	Node 21	Node 20	Node 19	Node 18	Node 17	Node 16
6603	Node 47	Node 46	Node 45	Node 44	Node 43	Node 42	Node 41	Node 40	Node 39	Node 38	Node 37	Node 36	Node 35	Node 34	Node 33	Node 32

Bit-Packed Discrete Input 1

Register Address	Bit Position															
	15	14	13	12	11	10	9	8	7	6	5	4	3	2	1	0
6611	Node 15	Node 14	Node 13	Node 12	Node 11	Node 10	Node 9	Node 8	Node 7	Node 6	Node 5	Node 4	Node 3	Node 2	Node 1	Gateway
6612	Node 31	Node 30	Node 29	Node 28	Node 27	Node 26	Node 25	Node 24	Node 23	Node 22	Node 21	Node 20	Node 19	Node 18	Node 17	Node 16
6613	Node 47	Node 46	Node 45	Node 44	Node 43	Node 42	Node 41	Node 40	Node 39	Node 38	Node 37	Node 36	Node 35	Node 34	Node 33	Node 32

Bit-Packed Discrete Output 1

Register Address	Bit Position															
	15	14	13	12	11	10	9	8	7	6	5	4	3	2	1	0
6691	Node 15	Node 14	Node 13	Node 12	Node 11	Node 10	Node 9	Node 8	Node 7	Node 6	Node 5	Node 4	Node 3	Node 2	Node 1	Gateway
6692	Node 31	Node 30	Node 29	Node 28	Node 27	Node 26	Node 25	Node 24	Node 23	Node 22	Node 21	Node 20	Node 19	Node 18	Node 17	Node 16
6693	Node 47	Node 46	Node 45	Node 44	Node 43	Node 42	Node 41	Node 40	Node 39	Node 38	Node 37	Node 36	Node 35	Node 34	Node 33	Node 32

Discrete bit-packed registers for inputs and outputs

Inputs		Outputs	
Modbus Register Address (Decimal)	Description (Inputs)	Modbus Register Address (Decimal)	Description (Outputs)
6601–6603	Status for all devices		
6611–6613	Input 1 from all devices	6691–6693	Output 1 from all devices
6621–6623	Input 2 from all devices	6701–6703	Output 2 from all devices
6631–6633	Input 3 from all devices	6711–6713	Output 3 from all devices
6641–6643	Input 4 from all devices	6721–6723	Output 4 from all devices
6651–6653	Input 5 from all devices	6731–6733	Output 5 from all devices
6661–6663	Input 6 from all devices	6741–6743	Output 6 from all devices
6671–6673	Input 7 from all devices	6751–6753	Output 7 from all devices
6681–6683	Input 8 from all devices		

Status registers (6601–6603) contain a bit-packed representation defining the devices that are operational in the wireless system. Each bit indicates Node in Sync (1) or Node Not in Sync (0).

A one (1) written to the Discrete Status Register area indicates the device is active within the wireless system. A zero (0) indicates the device is not active within the wireless network.

Input registers from all devices use Modbus registers 6611 through 6683 to organize the least significant bit into a sequential array of registers. The first register contains the least significant bit from the input values for the Gateway through Node 15. The second register contains the input values for Node 16 through Node 31, and the third register contains the input values for Nodes 32 through 47.

For discrete inputs, only the least significant bit is used. For analog inputs, the least significant bit indicates if the analog value is above or below the selected threshold value (when using the threshold parameter configured in the User Configuration Software). For example, a least significant bit of one (1) indicates the analog value is above the selected threshold value. A least significant bit of zero (0) indicates the analog value is below the threshold value.

Output registers from all devices use Modbus registers 6691 through 6753 to organize the least significant bit into a sequential array of registers. Output 8 (I/O point 16) cannot be written using the discrete format.

Analog 16-Bit Registers (Registers 6801 through 9098)

The most efficient way to read (or write) analog data from a Gateway is by using these 16-bit analog registers. Most networks consist of similar Nodes reporting data using the same I/O registers for each Node. For this reason, the analog data is arranged by I/O point using Modbus registers 6801 through 9098.

For example, Input 1 for Gateway and all Nodes is stored in the first 48 contiguous blocks of 16-bit analog registers, beginning with register 6801.

In this format, users can read a 16-bit holding register for all devices or write to a register for all devices using one Modbus message. Using these registers is the most efficient way to read all status registers, read all analog inputs, or write all analog outputs.

The following registers contain analog I/O values for the Gateway and all Nodes. Values are stored first for the Gateway, then for each Node in order of Node address.

Analog input and output registers

Inputs		Outputs	
Modbus Register Address (Decimal)	Description (Inputs)	Modbus Register Address (Decimal)	Description (Outputs)
6801	Input 1 for Gateway	8001	Output 1 for Gateway
6802	Input 1 for Node 1	8002	Output 1 for Node 1
6803	Input 1 for Node 2	8003	Output 1 for Node 2
...
6951	Input 2 for Gateway	8151	Output 2 for Gateway
6952	Input 2 for Node 1	8152	Output 2 for Node 1
6953	Input 2 for Node 2	8153	Output 2 for Node 2
...
7101	Input 3 for Gateway	8301	Output 3 for Gateway
7102	Input 3 for Node 1	8302	Output 3 for Node 1
7103	Input 3 for Node 2	8303	Output 3 for Node 2
...
7851	Input 8 (Status Register) for Gateway	9051	Output 8 for Gateway
7852	Input 8 (Status Register) for Node 1	9052	Output 8 for Node 1
7853	Input 8 (Status Register) for Node 2	9053	Output 8 for Node 2
...

For example, 6801 contains the input 1 value for the Gateway, 6802 contains the input 1 value for Node 1, and 6848 contains the input 1 value for Node 47.

Specifications

Radio Specifications for Performance Models

Supplied Antenna

A 2 dB antenna ships with this device. High-gain antennas are available, but the transmit power and range depends on the

antenna gain, environment, and line of sight. Always verify your wireless network's range by performing a Site Survey.

Radio Transmit Power (900 MHz, 1 Watt radios)

Conducted: 30 dBm (1 W)

EIRP with the supplied 2 dB antenna: < 36 dBm

Radio Transmit Power (2.4 GHz radios)

Conducted: < 18 dBm (65 mW)

EIRP with the supplied 2 dB antenna: < 20 dBm (100 mW)

Radio Range

900 MHz (in 1 Watt mode): Up to 9.6 km (6 miles) with the supplied 2 dB antenna

2.4 GHz: Up to 3.2 km (2 miles) with the supplied 2 dB antenna

Antenna Minimum Separation Distance

900 MHz (transmitting at 1 Watt): 4.57 m (15 ft) with the supplied 2 dB antenna

2.4 GHz: 0.3 m (1 ft) with the supplied 2 dB antenna

Link Timeout (Performance)

Gateway: Configurable via User Configuration Software

Node: Defined by Gateway

Spread Spectrum Technology

FHSS (Frequency Hopping Spread Spectrum)

Antenna Connection

Ext. Reverse Polarity SMA, 50 Ohms

Max Tightening Torque: 0.45 N·m (4 lbf·in)

900 MHz Compliance (SX7023EXT Radio Module)

Radio module is indicated by the product label marking

Contains FCC ID: UE3SX7023EXT: FCC Part 15, Subpart C, 15.247

Contains IC: 7044A-SX7023EXT

900 MHz Compliance (RM1809 Radio Module)

Radio module is indicated by the product label marking
Contains FCC ID: UE3RM1809: FCC Part 15, Subpart C, 15.247

Contains IC: 7044A-RM1809

IFT: RCPBARM13-2283



2.4 GHz Compliance (DX80-2400 Radio Module)

Radio module is indicated by the product label marking
Contains FCC ID: UE300DX80-2400: FCC Part 15, Subpart C, 15.247

Radio Equipment Directive (RED) 2014/53/EU

Contains IC: 7044A-DX8024

ANATEL: 15966-21-04042



2.4 GHz Compliance (SX243 Radio Module)

Radio module is indicated by the product label marking
Contains FCC ID: UE3SX243: FCC Part 15, Subpart C, 15.247

Radio Equipment Directive (RED) 2014/53/EU

ETSI/EN: EN 300 328 V2.2.2 (2019-07) [RED HarmStds]

Contains IC: 7044A-SX243

ANATEL: 03737-22-04042



PB2 Gateway Specifications

Supply Voltage

10 V DC to 30 V DC

Outside the USA: 12 V DC to 24 V DC, $\pm 10\%$; (For European applications, power this device from a Limited Power Source as defined in EN 60950-1.)

Wiring Access

Terminal block

Current Draw (at 24 V DC)

900 MHz, 1 Watt: Approx. 30 mA

900 MHz, 250 mW: Approx. 25 mA

2.4 GHz, 65 mW: Approx. 20 mA

Interface

One bi-color LED indicator; One button

Discrete Inputs

Two, PNP

Rating: 3 mA max current at 30 V DC

Sample Rate: 62.5 milliseconds

Report Rate: On change of state

ON Condition: Greater than 8 V

OFF Condition: Less than 5 V

Discrete Output

Two, PNP

Update Rate: 1 second

ON Condition (PNP): Supply minus 2 V

OFF Condition (PNP): Less than 2 V

Output State Following Timeout: De-energized (OFF)

Discrete Output Rating (PNP)

100 mA max current at 30 V DC

ON-State Saturation: Less than 3 V at 100 mA

OFF-state Leakage: Less than 10 μ A

Operating Conditions

$-40\text{ }^{\circ}\text{C}$ to $+85\text{ }^{\circ}\text{C}$ ($-40\text{ }^{\circ}\text{F}$ to $+185\text{ }^{\circ}\text{F}$)⁽¹⁾

95% maximum relative humidity (non-condensing)

Analog Inputs

Two, 0–20 mA

Rating: 24 mA

Impedance: Approximately 100 Ohms; To verify the analog input's impedance, use an Ohm meter to measure the resistance between the analog input terminal (AIx) and the ground (GND) terminal.

Sample Rate: 62.5 milliseconds

Accuracy: 0.1% of full scale $+0.01\%$ per $^{\circ}\text{C}$

Resolution: 12-bit

Analog Outputs

Two, 0–20 mA

Rating: 24 mA

Update Rate: 125 milliseconds

Accuracy: 0.1% of full scale $+0.01\%$ per $^{\circ}\text{C}$

Resolution: 12-bit

⁽¹⁾ Operating the devices at the maximum operating conditions for extended periods can shorten the life of the device.

Certification



Banner Engineering BV
 Park Lane, Culliganlaan 2F bus 3
 1831 Diegem, BELGIUM



Turck Banner LTD Blenheim House
 Blenheim Court
 Wickford, Essex SS11 8YT
 GREAT BRITAIN

(CE/UKCA approval only applies to 2.4 GHz models)

RS-485 Communication Specifications

Communication Hardware (RS-485)

Interface: 2-wire half-duplex RS-485

Baud rates: 9.6k, 19.2k (default), or 38.4k

Data format: 8 data bits, no parity, 1 stop bit

FCC Part 15 Class A for Intentional Radiators

This equipment has been tested and found to comply with the limits for a Class A digital device, pursuant to part 15 of the FCC Rules. These limits are designed to provide reasonable protection against harmful interference when the equipment is operated in a commercial environment. This equipment generates, uses, and can radiate radio frequency energy and, if not installed and used in accordance with the instruction manual, may cause harmful interference to radio communications. Operation of this equipment in a residential area is likely to cause harmful interference in which case the user will be required to correct the interference at his own expense.

Industry Canada Statement for Intentional Radiators

This device contains licence-exempt transmitters(s)/receiver(s) that comply with Innovation, Science and Economic Development Canada's licence-exempt RSS(s). Operation is subject to the following two conditions:

1. This device may not cause interference.
2. This device must accept any interference, including interference that may cause undesired operation of the device.

Cet appareil contient des émetteurs/récepteurs exemptés de licence conformes à la norme Innovation, Sciences, et Développement économique Canada. L'exploitation est autorisée aux deux conditions suivantes:

1. L'appareil ne doit pas produire de brouillage.
2. L'utilisateur de l'appareil doit accepter tout brouillage radioélectrique subi, même si le brouillage est susceptible d'en compromettre le fonctionnement.

MultiHop M-HBx and Performance PBx Models Mounted on the Base

Most MultiHop M-HBx and Performance PBx models ship from the factory mounted on a plastic base.

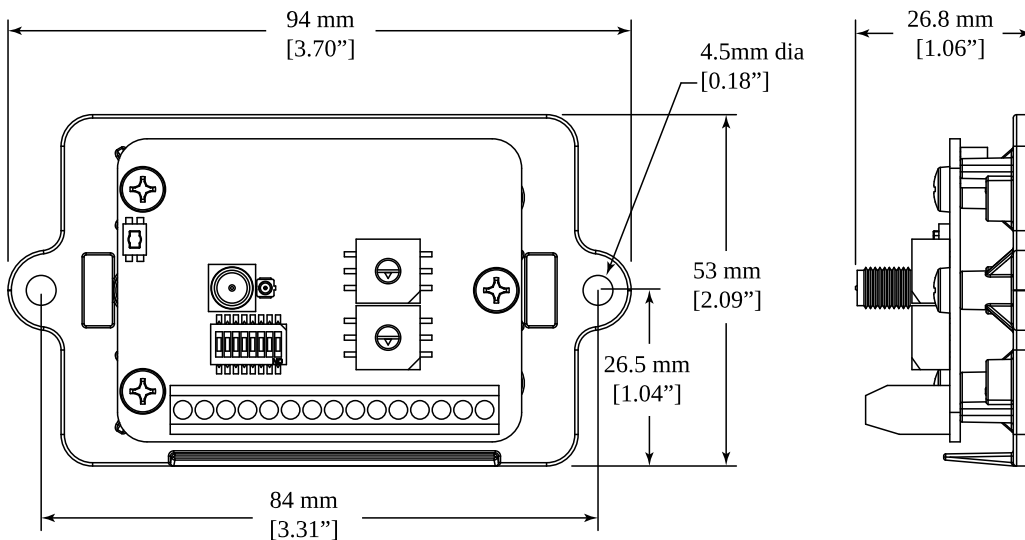

Accessories for the Board Models

BWA-HW-034

- DIN rail clip, black plastic



Warnings

WARNING:



- **Do not use this device for personnel protection**
- Using this device for personnel protection could result in serious injury or death.
- This device does not include the self-checking redundant circuitry necessary to allow its use in personnel safety applications. A device failure or malfunction can cause either an energized (on) or de-energized (off) output condition.

IMPORTANT: Please download the complete Performance PB2 Gateway Board Module technical documentation, available in multiple languages, from www.bannerengineering.com for details on the proper use, applications, Warnings, and installation instructions of this device.

IMPORTANT: Por favor descargue desde www.bannerengineering.com toda la documentación técnica de los Performance PB2 Gateway Board Module, disponibles en múltiples idiomas, para detalles del uso adecuado, aplicaciones, advertencias, y las instrucciones de instalación de estos dispositivos.

IMPORTANT: Veuillez télécharger la documentation technique complète des Performance PB2 Gateway Board Module sur notre site www.bannerengineering.com pour les détails sur leur utilisation correcte, les applications, les notes de sécurité et les instructions de montage.

Install and properly ground a qualified surge suppressor when installing a remote antenna system. Remote antenna configurations installed without surge suppressors invalidate the manufacturer's warranty. Keep the ground wire as short as possible and make all ground connections to a single-point ground system to ensure no ground loops are created. No surge suppressor can absorb all lightning strikes; do not touch the Sure Cross® device or any equipment connected to the Sure Cross® device during a thunderstorm.

Exporting Sure Cross® Radios. It is our intent to fully comply with all national and regional regulations regarding radio frequency emissions. **Customers who want to re-export this product to a country other than that to which it was sold must ensure the device is approved in the destination country.** The Sure Cross wireless products were certified for use in these countries using the antenna that ships with the product. When using other antennas, verify you are not exceeding the transmit power levels allowed by local governing agencies. This device has been designed to operate with the antennas listed on Banner Engineering's website and having a maximum gain of 9 dBm. Antennas not included in this list or having a gain greater than 9 dBm are strictly prohibited for use with this device. The required antenna impedance is 50 ohms. To reduce potential radio interference to other users, the antenna type and its gain should be so chosen such that the equivalent isotropically radiated power (EIRP) is not more than that permitted for successful communication. Consult with Banner Engineering Corp. if the destination country is not on this list.

IMPORTANT:

- **Never operate a 1 Watt radio without connecting an antenna**
- Operating 1 Watt radios without an antenna connected will damage the radio circuitry.
- To avoid damaging the radio circuitry, never apply power to a Sure Cross® Performance or Sure Cross MultiHop (1 Watt) radio without an antenna connected.

IMPORTANT:

- **Electrostatic discharge (ESD) sensitive device**
- ESD can damage the device. Damage from inappropriate handling is not covered by warranty.
- Use proper handling procedures to prevent ESD damage. Proper handling procedures include leaving devices in their anti-static packaging until ready for use; wearing anti-static wrist straps; and assembling units on a grounded, static-dissipative surface.

Banner Engineering Corp Limited Warranty

Banner Engineering Corp. warrants its products to be free from defects in material and workmanship for one year following the date of shipment. Banner Engineering Corp. will repair or replace, free of charge, any product of its manufacture which, at the time it is returned to the factory, is found to have been defective during the warranty period. This warranty does not cover damage or liability for misuse, abuse, or the improper application or installation of the Banner product.

THIS LIMITED WARRANTY IS EXCLUSIVE AND IN LIEU OF ALL OTHER WARRANTIES WHETHER EXPRESS OR IMPLIED (INCLUDING, WITHOUT LIMITATION, ANY WARRANTY OF MERCHANTABILITY OR FITNESS FOR A PARTICULAR PURPOSE), AND WHETHER ARISING UNDER COURSE OF PERFORMANCE, COURSE OF DEALING OR TRADE USAGE.

This Warranty is exclusive and limited to repair or, at the discretion of Banner Engineering Corp., replacement. **IN NO EVENT SHALL BANNER ENGINEERING CORP. BE LIABLE TO BUYER OR ANY OTHER PERSON OR ENTITY FOR ANY EXTRA COSTS, EXPENSES, LOSSES, LOSS OF PROFITS, OR ANY INCIDENTAL, CONSEQUENTIAL OR SPECIAL DAMAGES RESULTING FROM ANY PRODUCT DEFECT OR FROM THE USE OR INABILITY TO USE THE PRODUCT, WHETHER ARISING IN CONTRACT OR WARRANTY, STATUTE, TORT, STRICT LIABILITY, NEGLIGENCE, OR OTHERWISE.**

Banner Engineering Corp. reserves the right to change, modify or improve the design of the product without assuming any obligations or liabilities relating to any product previously manufactured by Banner Engineering Corp. Any misuse, abuse, or improper application or installation of this product or use of the product for personal protection applications when the product is identified as not intended for such purposes will void the product warranty. Any modifications to this product without prior express approval by Banner Engineering Corp will void the product warranties. All specifications published in this document are subject to change; Banner reserves the right to modify product specifications or update documentation at any time. Specifications and product information in English supersede that which is provided in any other language. For the most recent version of any documentation, refer to: www.bannerengineering.com.

For patent information, see www.bannerengineering.com/patents.

Notas Adicionales (con Antena)

Información México: La operación de este equipo está sujeta a las siguientes dos condiciones: 1) es posible que este equipo o dispositivo no cause interferencia perjudicial y 2) este equipo debe aceptar cualquier interferencia, incluyendo la que pueda causar su operación no deseada.

Banner es una marca registrada de Banner Engineering Corp. y podrán ser utilizadas de manera indistinta para referirse al fabricante. "Este equipo ha sido diseñado para operar con las antenas tipo Omnidireccional para una ganancia máxima de antena de 6 dBd y Yagi para una ganancia máxima de antena 10 dBd que en seguida se enlistan. También se incluyen aquellas con aprobación ATEX tipo Omnidireccional siempre que no excedan una ganancia máxima de antena de 6dBd. El uso con este equipo de antenas no incluidas en esta lista o que tengan una ganancia mayor que 6 dBd en tipo omnidireccional y 10 dBd en tipo Yagi, quedan prohibidas. La impedancia requerida de la antena es de 50 ohms."

Approved Antennas

- BWA-902-C**--Antena, Omni 902-928 MHz, 2 dBd, junta de caucho, RP-SMA Macho
- BWA-905-C**--Antena, Omni 902-928 MHz, 5 dBd, junta de caucho, RP-SMA Macho
- BWA-906-A**--Antena, Omni 902-928 MHz, 6 dBd, fibra de vidrio, 1800mm, N Hembra
- BWA-9Y10-A**--Antena, Yagi, 900 MHz, 10 dBd, N Hembra

Mexican Importer

Banner Engineering de México, S. de R.L. de C.V. | David Alfaro Siqueiros 103 Piso 2 Valle oriente | San Pedro Garza Garcia Nuevo León, C. P. 66269

81 8363.2714

Document title: Sure Cross® Performance Gateway PB2 Board Module

Part number: 163211

Revision: L

Original Instructions

© Banner Engineering Corp. All rights reserved.

