

**STRAIGHT PLUG CLAMP TYPE  
CABLE 6/75+93**

**R162.012.000**  
**SERIES N 75**

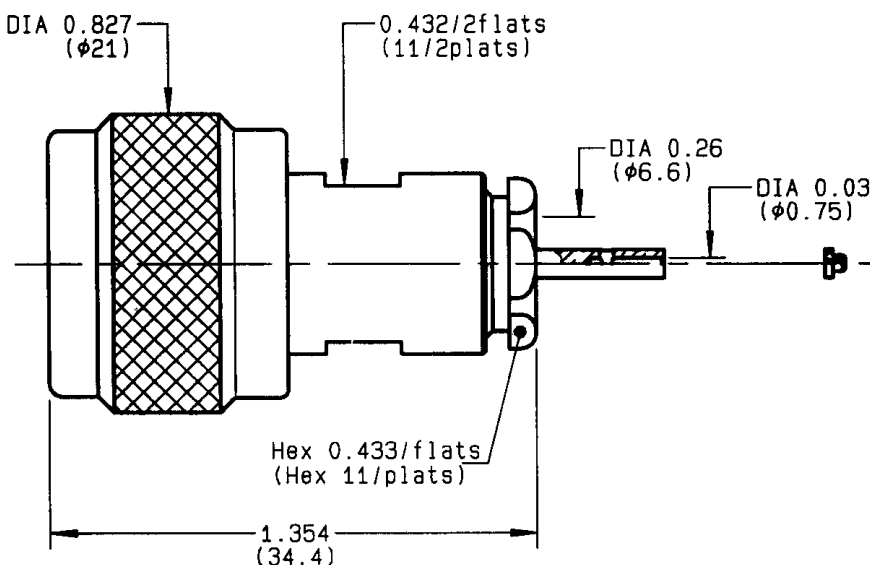

NOMINAL IMPEDANCE	<b>75</b> Ω
FREQUENCY RANGE	<b>0-1.5</b> GHz
TEMPERATURE RATING	<b>-55/+155</b> °C
V.S.W.R	<b>1.06</b> + x F(GHz)Maxi
RF INSERTION LOSS	<b>0.15</b> √F(GHz) dB Maxi
VOLTAGE RATING	<b>850</b> Veff Maxi
DIELECTRIC WITHSTANDING VOLTAGE	<b>1500</b> Veff Mini
INSULATION RESISTANCE	<b>5000</b> M ΩMini
HERMETIC SEAL	<b>NA</b> Atm.cm <sup>3</sup> /s
LEAKAGE (pressurized only)	<b>NA</b>
MECHANICAL DURABILITY	<b>500</b> Cycles
WEIGHT	<b>31.8</b> gr
SPECIFICATION	

CABLES : **KX 6A**  
**RG 59**  
**RG 62**

OTHERS CHARACTERISTICS

CABLE RETENTION	<b>200</b> N Mini
CENTER CONTACT RETENTION	
Axial force - mating end	<b>NA</b> N Mini
Axial force - opposite end	<b>NA</b> N Mini
Torque	<b>NA</b> cm.N Mini
RECOMMENDED TORQUES	
Mating	<b>130</b> cm.N
Panel nut	<b>NA</b> cm.N
Clamp nut	<b>450</b> cm.N

CONNECTOR PARTS	MATERIALS	FINISH	(all values are given in micrometers)
BODY	BRASS	BBR 2	
OUTER CONTACT	BRASS	BBR 2	
CENTER CONTACT	BRASS	GOLD 0.5 OVER NICKEL 2	
INSULATOR	PTFE	-	
GASKET	SILICONE RUBBER	-	
OTHERS PIECES	BRASS	BBR 2	

ISSUE	CREATION DATE	FILE PART-NUMBER
<b>9813J01</b>	<b>26-OCT-93</b>	<b>EPC 96-07</b>



**RADIALL®**

*Connect to the future*

The information given here is subject to change without notice. Design changes may be in order to improve the product.



**RADIALL®**

**R162.012.000**

ISSUE 9813J01

SERIES N 75

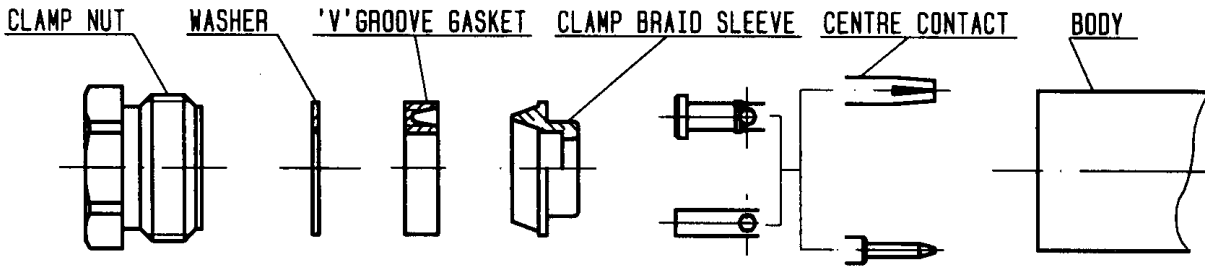

①

Strip the cable .

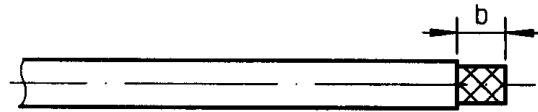

Stripping	a	b	c	d	e
inch	0.157	0.315	0	0	0.079
mm	4	8			2

②

Slide the clamp nut , the washer and the 'V' groove gasket onto the cable .  
 Slide clamp braid sleeve over braid .  
 Fold back braid and trim off surplus braid .  
 Trim back dielectric as shown .  
 -  
 NOTE: For air-space PE cables , "e" = 0.039  
 Introduce insulator onto dielectric cable .

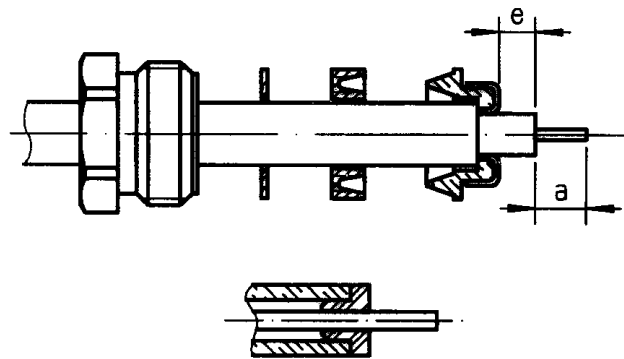

③

Solder the cable inner conductor into centre contact .

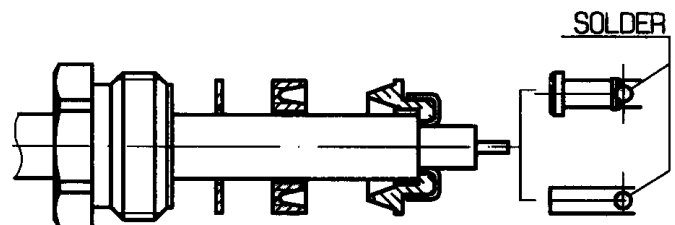

④

Screw sub-assembly into the connector body .  
 ( recommended coupling torque 39.82 in.lb )

