

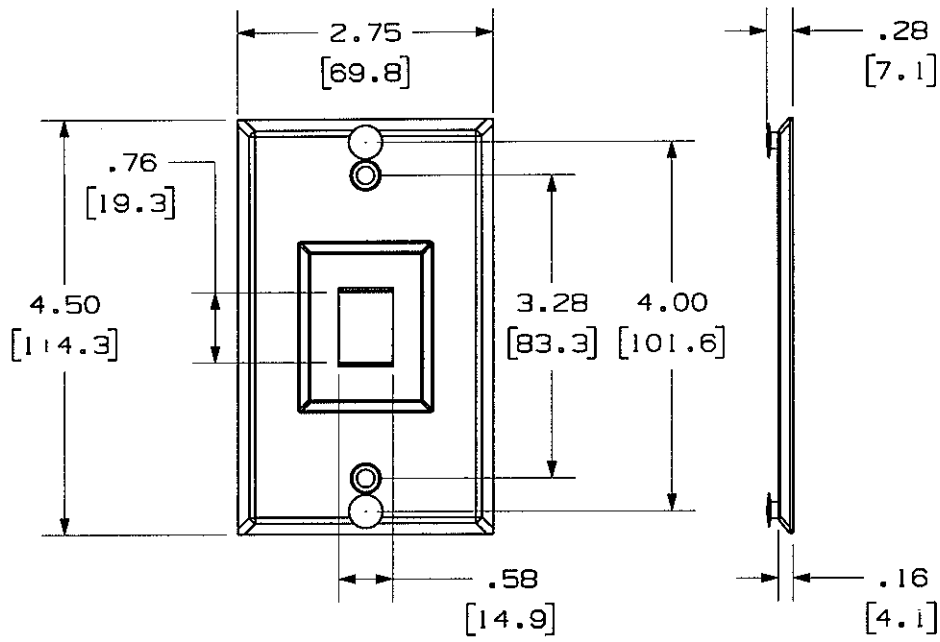

THIS COPY IS PROVIDED ON A RESTRICTED BASIS AND IS NOT TO BE USED IN ANY WAY DETRIMENTAL TO THE INTERESTS OF PANDUIT CORP.

PANDUIT P/N	WEIGHT
KWP3Y	1.40 LB/10 PCS (635.3 g/10 PCS)

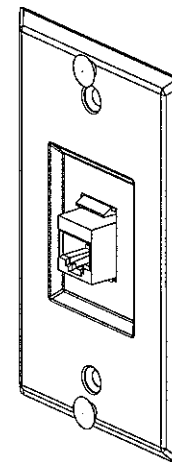

- NOTES:
- SEE CATALOG FOR COMPLETE LIST OF PARTS APPLICABLE FOR USE WITH THIS PART.
 - DIMENSIONS IN PARENTHESES ARE IN METRIC.
 - KWP3Y CONTAINS:
 - 1- WALL PLATE
 - 1- CAT. 3 KEYSTONE JACK
 - 2- MOUNTING SCREW



DRAWING FILENAME		M02479BL_DC38_00A.PRT		SIZE	A
PHONE PLATE WITH CAT. 3 KEYSTONE JACK CUSTOMER DRAWING					
 PANDUIT ™ CORP. TINLEY PARK, ILL 60477		I.I. NUMBER		N/A	
ALL DIMENSIONS ARE GIVEN IN INCHES, UNLESS OTHERWISE SPECIFIED. DIMENSIONAL TOLERANCES ARE: (.X) ± (.XXX) ± .0101.31 (.XX) ± .031.81 ANGLES ±		PRODUCT SPEC		N/A	
 THIRD ANGLE PROJECTION		WORK INSTRUCTION		N/A	
DRAWN BY		MATERIAL:		SCALE	
JsP		20 AWG 430 STAINLESS STEEL		NONE	
DATE		PART NO.		DRAWING NO.	
5-3-06		KWP3Y		02479-038	
REV		DESCRIPTION		CHK'D	
M/J		RELEASED TO PRODUCTION		M/J	
5-3-06		ECN - R		CUST SUP OTH	
BY		M/J		M/J	

REV	DATE	BY	CHK	DESCRIPTION	ECN	R	CUST	SUP	OTH
R	5-3-06	JsP	M/J	RELEASED TO PRODUCTION	02479-038	M/J	M/J		