

DO NOT
SCALE FROM
THIS PRINT

**DESIGNED & DIMENSIONED
IN INCHES [MILLIMETERS]**

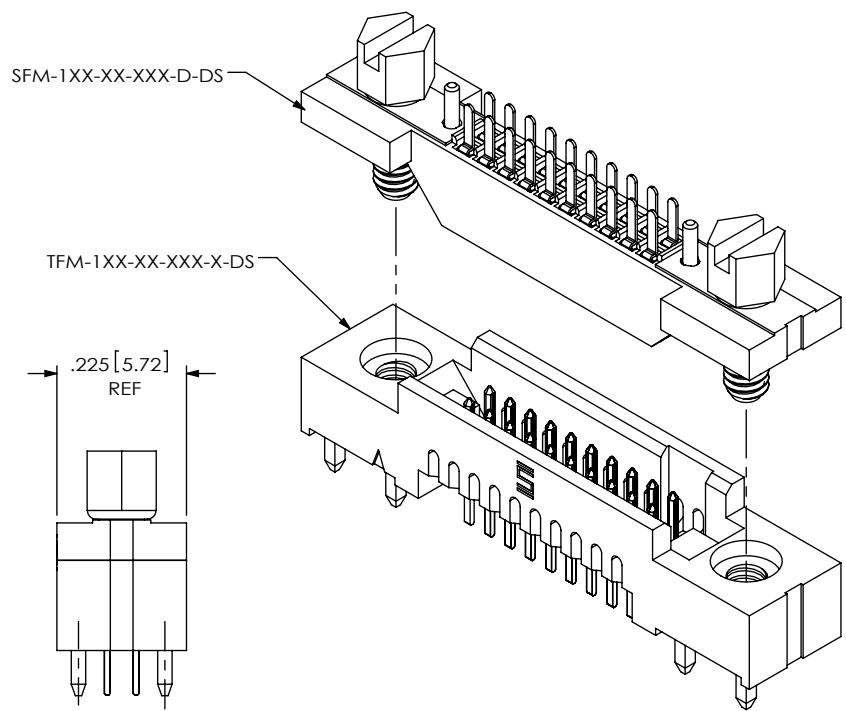
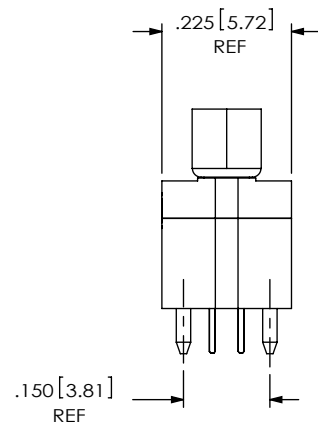
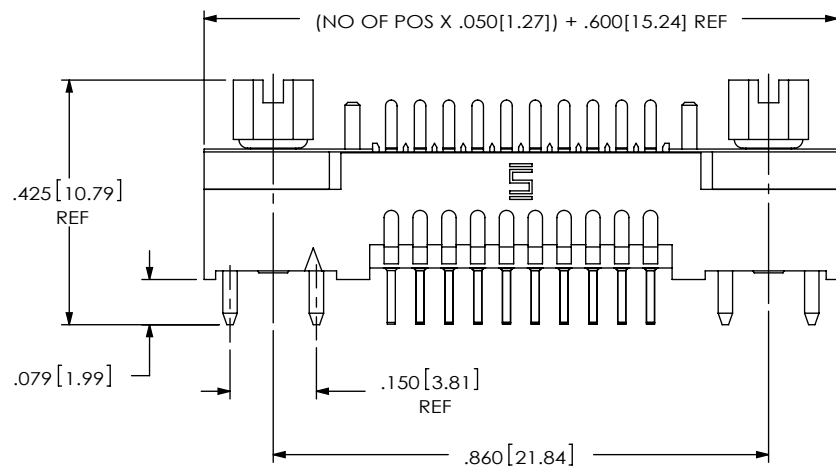
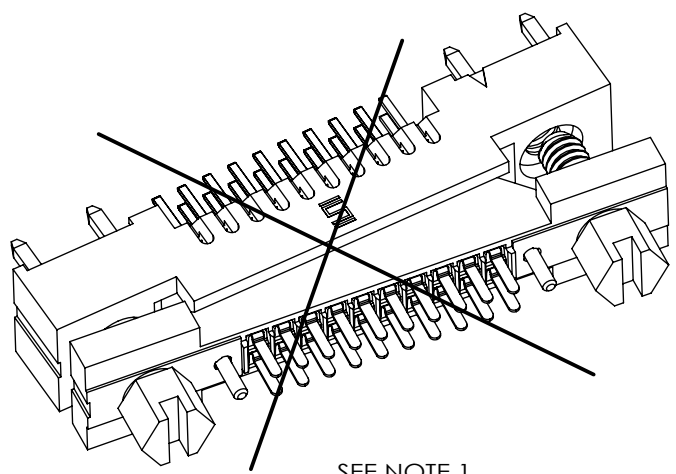

FIG 1
TFM-1XX-XX-XXX-X-DS & SFM-1XX-XX-XXX-D-DS MATING



SEE NOTE 1

NOTES:

1. SCREWS MUST BE TIGHTENED IN .060" INCREMENTS, ALTERNATING SIDE TO SIDE; TIGHTEN FASTNERS TO 8 IN OZ MAX.
2. STANDARD .100" SCREW DRIVER RECOMMENDED.

PROPRIETARY NOTE
THIS DOCUMENT CONTAINS INFORMATION CONFIDENTIAL AND PROPRIETARY TO SAMTEC, INC. AND SHALL NOT BE REPRODUCED OR TRANSFERRED TO OTHER DOCUMENTS OR DISCLOSED TO OTHERS OR USED FOR ANY PURPOSE OTHER THAN THAT WHICH IT WAS OBTAINED WITHOUT THE EXPRESSED WRITTEN CONSENT OF SAMTEC, INC.

DO NOT SCALE DRAWING
SHEET SCALE: 4:1



520 PARK EAST BLVD, NEW ALBANY, IN 47150
PHONE: 812-944-6733 FAX: 812-948-5047
e-Mail info@SAMTEC.com code 55322

DESCRIPTION:
SCREW DOWN APPLICATION

DWG. NO.
TFM SFM SFSD ISDF SCREW DOWN OPTION APPLICATION

BY: ROY LUO 07/09/2011 SHEET 1 OF 3

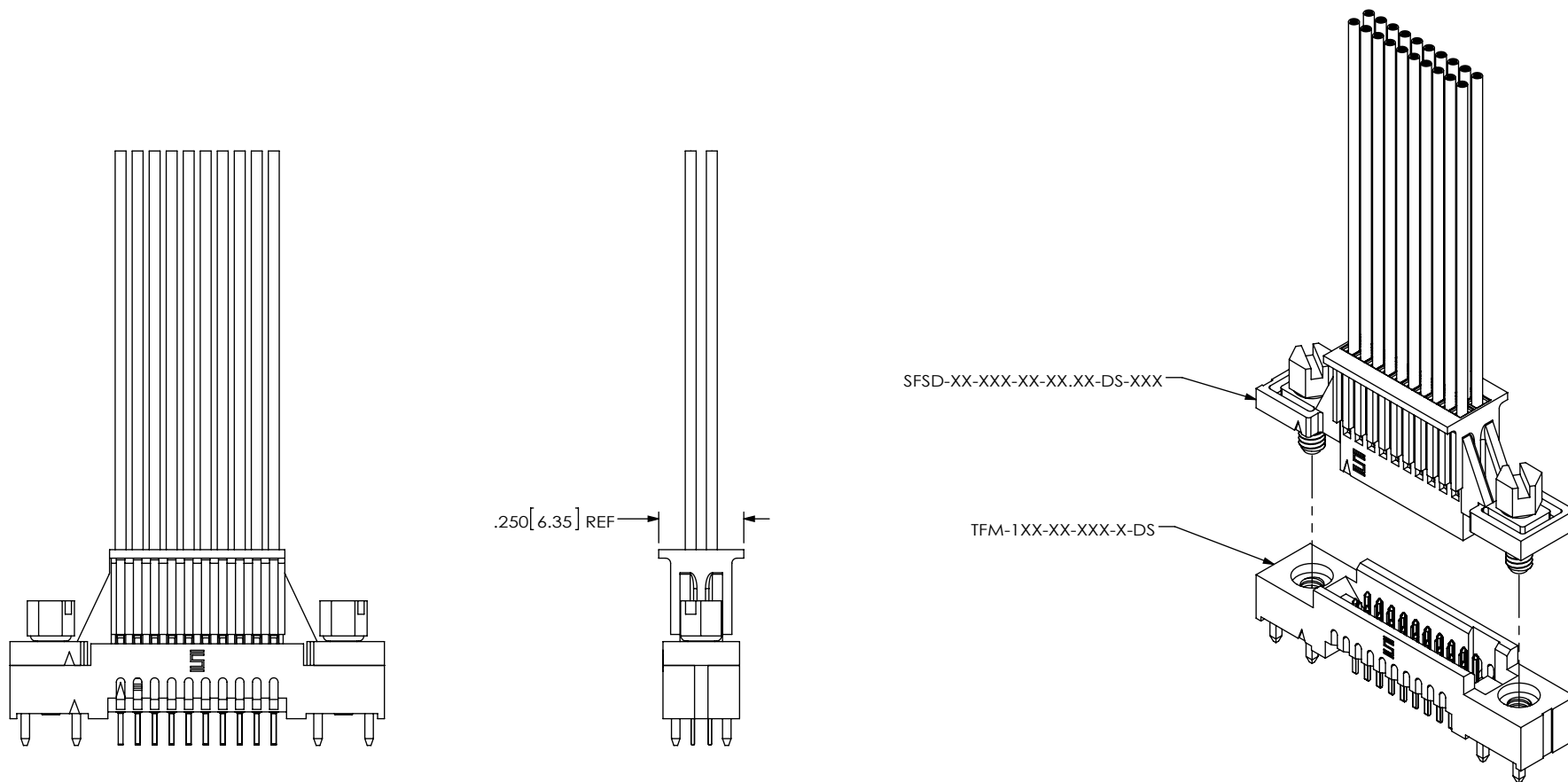



FIG 2
TFM-1XX-XX-XXX-X-DS & SFSD-XX-XXX-XX-XX.XX-DS-XXX MATING
(SAME AS FIG 1, UNLESS OTHERWISE STATED)

<p>PROPRIETARY NOTE THIS DOCUMENT CONTAINS INFORMATION CONFIDENTIAL AND PROPRIETARY TO SAMTEC, INC. AND SHALL NOT BE REPRODUCED OR TRANSFERRED TO OTHER DOCUMENTS OR DISCLOSED TO OTHERS OR USED FOR ANY PURPOSE OTHER THAN THAT WHICH IT WAS OBTAINED WITHOUT THE EXPRESSED WRITTEN CONSENT OF SAMTEC, INC.</p> <p>DO NOT SCALE DRAWING</p> <p>SHEET SCALE: 2:1</p>		
	<p>520 PARK EAST BLVD, NEW ALBANY, IN 47150 PHONE: 812-944-6733 FAX: 812-948-5047 e-Mail: info@SAMTEC.com code 55322</p>	
	<p>DESCRIPTION: SCREW DOWN APPLICATION</p>	
	<p>DWG. NO. TFM SFM SFSD ISDF SCREW DOWN OPTION APPLICATION</p>	
<p>BY: ROY LUO 07/09/2011</p>		<p>SHEET 2 OF 3</p>

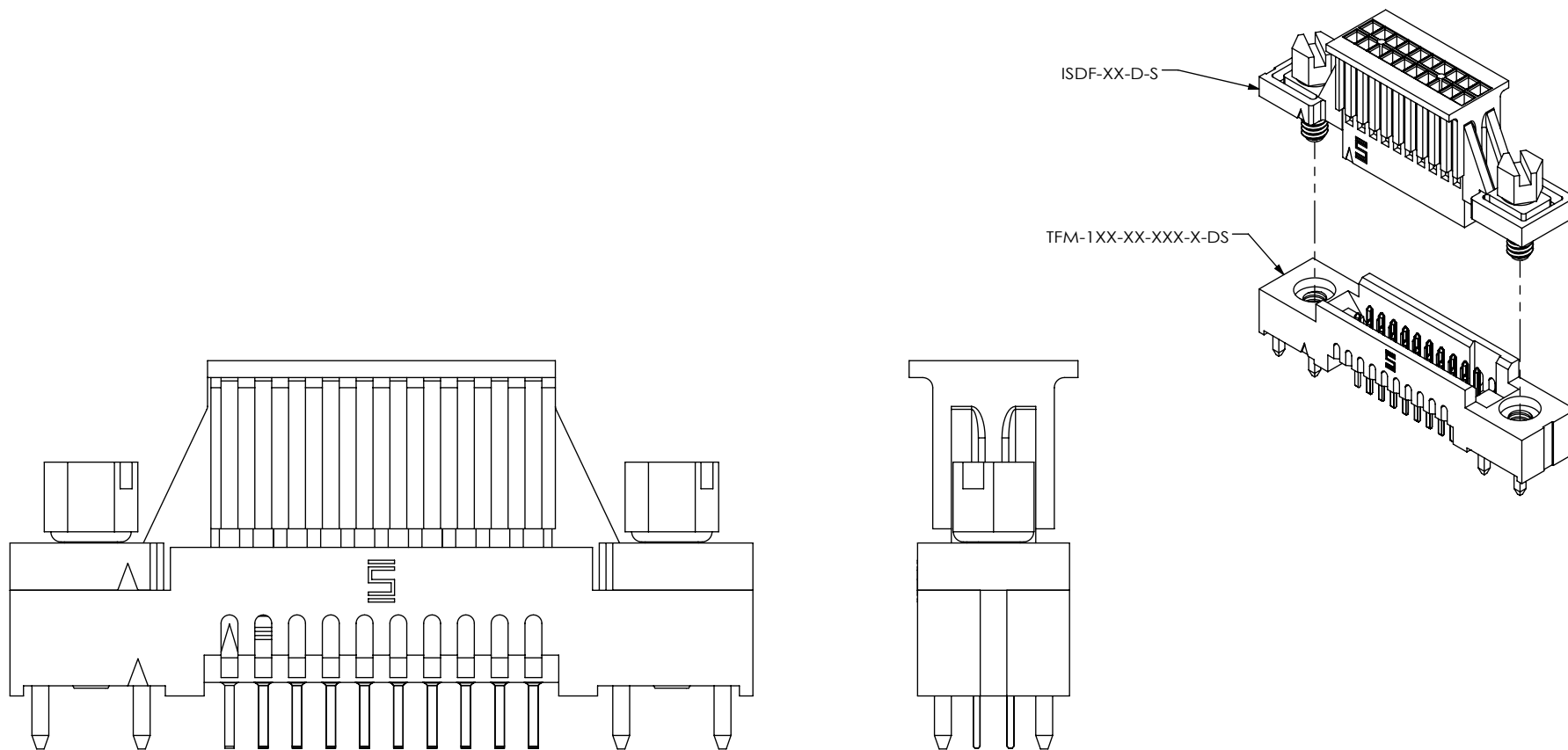

FIG 3
TFM-1XX-XX-XXX-X-DS & ISDF-XX-D-S MATING
(SAME AS FIG 1, UNLESS OTHERWISE STATED)

PROPRIETARY NOTE

THIS DOCUMENT CONTAINS INFORMATION CONFIDENTIAL AND PROPRIETARY TO SAMTEC, INC. AND SHALL NOT BE REPRODUCED OR TRANSFERRED TO OTHER DOCUMENTS OR DISCLOSED TO OTHERS OR USED FOR ANY PURPOSE OTHER THAN THAT WHICH IT WAS OBTAINED WITHOUT THE EXPRESSED WRITTEN CONSENT OF SAMTEC, INC.

DO NOT SCALE DRAWING

SHEET SCALE: 4:1



520 PARK EAST BLVD, NEW ALBANY, IN 47150
PHONE: 812-944-6733 FAX: 812-948-5047
e-Mail info@SAMTEC.com code 55322

DESCRIPTION:
SCREW DOWN APPLICATION

DWG. NO.
TFM SFM SFSD ISDF SCREW DOWN OPTION APPLICATION

BY: ROY LUO 07/09/2011 SHEET 3 OF 3