

TMI8870/B 3.6-A Brushed DC Motor Driver

FEATURES

- H-Bridge Motor Driver
Drives One DC Motor, One Winding of a Stepper Motor, or Other Loads
- Wide 6.8V to 45V Operating Voltage
- 3.6-A Peak Current Drive
- PWM Control Interface
- Integrated Current Regulation
- Low-Power Sleep Mode
- VM Undervoltage Lockout (UVLO)
- Overcurrent Protection (OCP)
 - Retry After OCP: TMI8870
 - Latch After OCP: TMI8870B
- Thermal Shutdown (TSD)
- Automatic Fault Recovery
- ESOP8 Small Package and Footprint

APPLICATIONS

- Printers
- Appliances
- Industrial Equipment
- Other Mechatronics Applications

TYPICAL APPLICATION

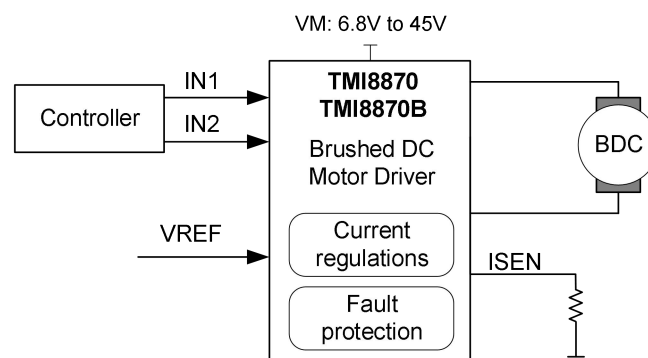
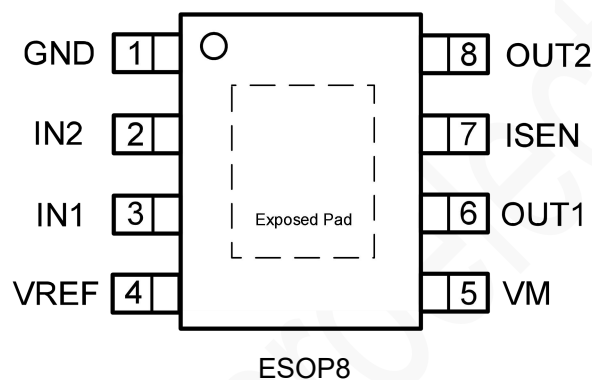

Figure 1. Basic Application Circuit

ABSOLUTE MAXIMUM RATINGS (Note 1)

Parameter	Value	Unit
Power supply voltage (VM)	-0.3~45	V
Logic input voltage (IN1, IN2)	-0.3~6	V
Reference input pin voltage (VREF)	-0.3~6	V
Continuous phase node pin voltage (OUT1, OUT2)	-0.7~(VM+0.7)	V
Current sense input pin voltage (ISEN)	-0.5~1	V
Output current (100% duty cycle)	0~3.5	A
Operating junction temperature (Note 2)	-40~150	°C
Storage temperature	-65~150	°C

PACKAGE/ORDER INFORMATION



Top Mark: T8870/YYXXX (T8870: Device Code, YYXXX: Inside Code)
T8870B/YYXXX (T8870B: Device Code, YYXXX: Inside Code)

Part Number	Package	Top mark	Quantity/ Reel
TMI8870	ESOP8	T8870 YYXXX	3000
TMI8870B	ESOP8	T8870B YYXXX	3000

TMI8870 and TMI8870B devices are Pb-free and RoHS compliant.

PIN FUNCTIONS

Pin	Name	Function
1	GND	Logic ground. Connect to board ground
2	IN2	Logic inputs. Controls the H-bridge output. Has internal pulldowns.
3	IN1	Logic inputs. Controls the H-bridge output. Has internal pulldowns.
4	VREF	Analog input. Apply a voltage between 0.3V to 5V. The voltage of VREF pin and the resistance value connected to ISEN pin determine the maximum value of current limiting.
5	VM	6.8V to 45V power supply. Connect a 0.1 μ F bypass capacitor to ground, as well as sufficient bulk capacitance, rated for the VM voltage.
6	OUT1	H-bridge output. Connect directly to the motor or other inductive load.
7	ISEN	High-current ground path. If using current regulation, connect ISEN to a resistor (low-value, high-power-rating) to ground. If not using current regulation, connect ISEN directly to ground.
8	OUT2	H-bridge output. Connect directly to the motor or other inductive load.

ESD RATING

Items	Description	Value	Unit
V _{ESD}	Human Body Model for all pins	\pm 2000	V

JEDEC specification JS-001

RECOMMENDED OPERATING CONDITIONS

Items	Description	Min	Max	Unit
VM	Power supply voltage range	6.8	45	V
T _J	Operating Junction Temperature Range	-40	125	$^{\circ}$ C

ELECTRICAL CHARACTERISTICS

$T_A = 25^\circ\text{C}$, over recommended operating conditions unless otherwise noted.)

PARAMETER	SYMBOL	TEST CONDITIONS	MIN	TYP	MAX	UNIT
POWER SUPPLY (VM)						
VM operating voltage	VM		6.8		45	V
VM operating supply current	I_{VM}	VM = 12V		3		mA
VM sleep current	$I_{VMSLEEP}$	VM = 12V			1	μA
Turn-on time (Note 3)	t_{ON}	VM > VUVLO with IN1 or IN2 high		30		μs
LOGIC-LEVEL INPUTS (IN1, IN2)						
Input logic low voltage	V_{IL}				0.5	V
Input logic high voltage	V_{IH}		1.6			V
Input logic hysteresis	V_{HYS}			0.5		V
Input logic low current	I_{IL}	VIN = 0V	-1		1	μA
Input logic high current	I_{IH}	VIN = 3.3V		62		μA
Pulldown resistance	R_{PD}	to GND		53		k Ω
Propagation delay	t_{PD}	INx to OUTx change		0.7		μs
Time to sleep	t_{sleep}	Inputs low to sleep		1		ms
MOTOR DRIVER OUTPUTS (OUT1, OUT2)						
High-side FET on resistance	$R_{DS(ON)_{High}}$	VM = 24 V, $I_{OUT} = 1\text{A}$,		430		m Ω
Low-side FET on resistance	$R_{DS(ON)_{Low}}$	VM = 24 V, $I_{OUT} = 1\text{A}$,		480		m Ω
Output dead time	t_{DEAD}			220		ns
Body diode forward voltage	V_d	$I_{OUT} = 1\text{A}$		0.9		V
CURRENT REGULATION						
ISEN gain	A_V	VREF = 2.5V		10		V/V
PWM off-time	t_{OFF}			25		μs
PWM blanking time	t_{BLANK}			2		μs
PROTECTION CIRCUITS						
VM undervoltage lockout	V_{UVLO_fall}	VM falls until UVLO triggers		6.2		V
	V_{UVLO_rise}	VM rises until operation recovers		6.5		V
VM undervoltage hysteresis	V_{UV_HYS}	Rising to falling threshold		240		mV
Overcurrent protection trip level	I_{OCP}			4.5		A
Overcurrent deglitch time	t_{OCP}			1.8		μs
Overcurrent retry time	t_{RETRY}			3		ms

ELECTRICAL CHARACTERISTICS (Continued)

PARAMETER	SYMBOL	TEST CONDITIONS	MIN	TYP	MAX	UNIT
Thermal shutdown threshold (Note 4)	T _{SD}			150		°C
Thermal shutdown hysteresis (Note 4)	T _{HYS}			30		°C

Note 1: Absolute Maximum Ratings are those values beyond which the life of a device may be impaired.

Note 2: T_J is calculated from the ambient temperature T_A and power dissipation P_D according to the following formula: $T_J = T_A + P_D \times \theta_{JA}$. The maximum allowable continuous power dissipation at any ambient temperature is calculated by $P_{D(MAX)} = (T_{J(MAX)} - T_A) / \theta_{JA}$.

Note 3: t_{ON} applies when the device initially powers up, and when it exits sleep mode.

Note 4: Thermal shutdown threshold and hysteresis are guaranteed by design.

OPERATION

Overview

The TMI8870/B devices are optimized 8-pin devices for driving brushed DC motors with 6.8V to 45 V and up to 3.6-A peak current. The integrated current regulation restricts motor current to a predefined maximum. Two logic inputs control the H-bridge driver, which consists of four N-channel MOSFETs that have a typical R_{DS(ON)} of 0.9Ω (including one high-side and one low-side FET). A single-power input, VM, serves as both device power and the motor winding bias voltage. The integrated charge pump of the device boosts VM internally and fully enhances the high-side FETs. Motor speed can be controlled with pulse-width modulation, at frequencies between 0 to 100kHz. The devices have an integrated sleep mode that is entered by bringing both inputs low. An assortment of protection features prevents the device from being damaged if a system fault occurs.

Bridge Control

The TMI8870/B output consists of four N-channel MOSFETs that are designed to drive high current. These outputs are controlled by the two logic inputs IN1 and IN2 as listed in Table 1.

Table 1. H-Bridge Control

IN1	IN2	OUT1	OUT2	DESCRIPTION
0	0	High-Z	High-Z	Coast; H-bridge disabled to High-Z (sleep entered after 1ms)
0	1	L	H	Reverse (Current OUT2 → OUT1)
1	0	H	L	Forward (Current OUT1 → OUT2)
1	1	L	L	Brake; low-side slow decay

The inputs can be set to static voltages for 100% duty cycle drive, or they can be pulse-width modulated (PWM) for variable motor speed. When using PWM, switching between driving and

braking typically works best. For example, to drive a motor forward with 50% of the maximum RPM, IN1 = 1 and IN2 = 0 during the driving period, and IN1 = 1 and IN2 = 1 during the other period. Alternatively, the coast mode (IN1 = 0, IN2 = 0) for fast current decay is also available. The input pins can be powered before VM is applied.

Sleep Mode

When the IN1 and IN2 pins are both low for time t_{SLEEP} (typically 1 ms), the TMI8870/B device enters a low-power sleep mode, where the outputs remain High-Z and the device uses $I_{VMSLEEP}$ (μA) of current. If the device is powered up while both inputs are low, it immediately enters sleep mode. After the IN1 or IN2 pins are high for at least 5 μs , the device is operational 30 μs (t_{ON}) later.

Current Regulation

In TMI8870/B, motor peak current can be limited by the analog reference input VREF and the resistance of external sense resistor on the ISEN pin approximately according to the below equation:

$$I_{TRIP} (A) = \frac{V_{REF} (V)}{A_V \times R_{ISEN} (\Omega)} = \frac{V_{REF} (V)}{10 \times R_{ISEN} (\Omega)}$$

For example, if $V_{REF} = 3.6 V$ and a $R_{ISEN} = 0.18 \Omega$, the TMI8870 will limit motor current to 2.0 A no matter how much load torque is applied.

When $I_{TRIP}(A)$ has been reached, the device enforces mixed current decay, which means the device goes into fast decay mode for 50% of the fixed off-time period. After this fast decay portion the device switches to slow decay mode for the remainder of the t_{OFF} (typically 25 μs).

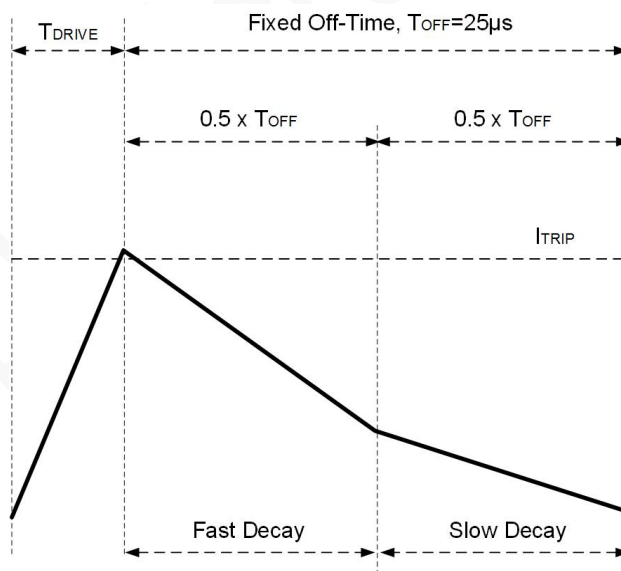

Figure 2. TMI8870/B Current Regulation Time Periods

After t_{OFF} has elapsed, the output is re-enabled according to the two inputs INx. The drive time (t_{DRIVE}) until reaching another $I_{TRIP}(A)$ event heavily depends on the VM voltage, the motor's back-EMF, and the motor's inductance.

VM Undervoltage Lockout (UVLO)

If at any time the voltage on the VM pin falls below the undervoltage-lockout threshold voltage, all FETs in the H-bridge will be disabled. Operation resumes when VM rises above the UVLO threshold.

Overcurrent Protection (OCP)

If the output current exceeds the OCP threshold, IOCP, for longer than t_{OCP} , all FETs in the H-bridge are disabled.

As to TMI8870, after a duration of t_{RETRY} , the H-bridge is re-enabled according to the state of the INx pins. If the overcurrent fault is still present, the cycle repeats; otherwise normal device operation resumes.

As to TMI8870B, after OCP events, the device is latched and it can only be reset by putting the device into sleep mode or by restarting the power of VM.

Thermal Shutdown (TSD)

If the die temperature exceeds safe limits, all FETs in the H-bridge are disabled. After the die temperature has fallen to a safe level, operation automatically resumes.

Device Functional Modes

The TMI8870/B devices can be used in multiple ways to drive a brushed DC motor.

PWM With Current Regulation

This scheme uses all of the capabilities of the device. The I_{TRIP} current is set above the normal operating current, and high enough to achieve an adequate spin-up time, but low enough to constrain current to a desired level. Motor speed is controlled by the duty cycle of one of the inputs, while the other input is static. Brake or slow decay is typically used during the off-time.

PWM Without Current Regulation

If current regulation is not required, the ISEN pin should be directly connected to the PCB ground plane. The VREF voltage must still be 0.3V to 5 V, and larger voltages provide greater noise margin. This mode provides the highest-possible peak current which is up to 3.6 A for a few hundred milliseconds (depending on PCB characteristics and the ambient temperature). If current exceeds 3.6 A, the device might reach overcurrent protection (OCP) or overtemperature shutdown (TSD). If that happens, the device disables and protects itself for about 3ms (t_{RETRY}) and then resumes normal operation.

Static Inputs with Current Regulation

The IN1 and IN2 pins can be set high and low for 100% duty cycle drive, and I_{TRIP} can be used to control the current of the motor, speed, and torque capability.

VM Control

In some systems, varying VM as a means of changing motor speed is desirable. In application, local bulk capacitance is needed on VM to GND to stable VM voltage during the operation with motor starts up or stops. At least a 47 μ F bulk capacitor with voltage rating of operation voltage is recommended. However, the system-level testing is required to determine the appropriate size bulk capacitors.

APPLICATION INFORMATION

Application information

The TMI8870/B devices are typically used to drive one brushed DC motor as below:

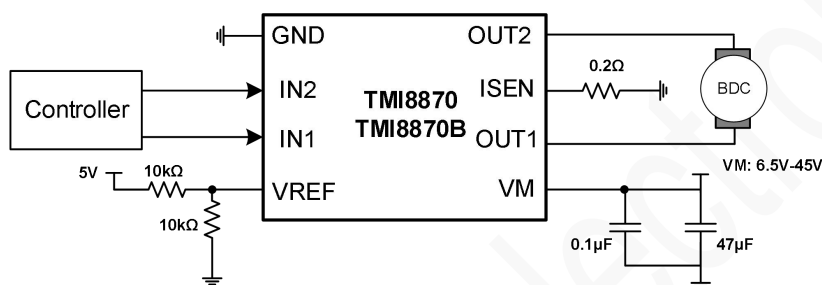

Figure 3. TMI8870/B Typical Application

Note 5: The voltage divider resistances connected to VREF pin and the sense resistor connected to ISEN pin determine the maximum working current. If the regulation function is not needed, the VREF pin should be connected to 5V power supply and sense resistor can be connected directly to GND.

Block Diagram

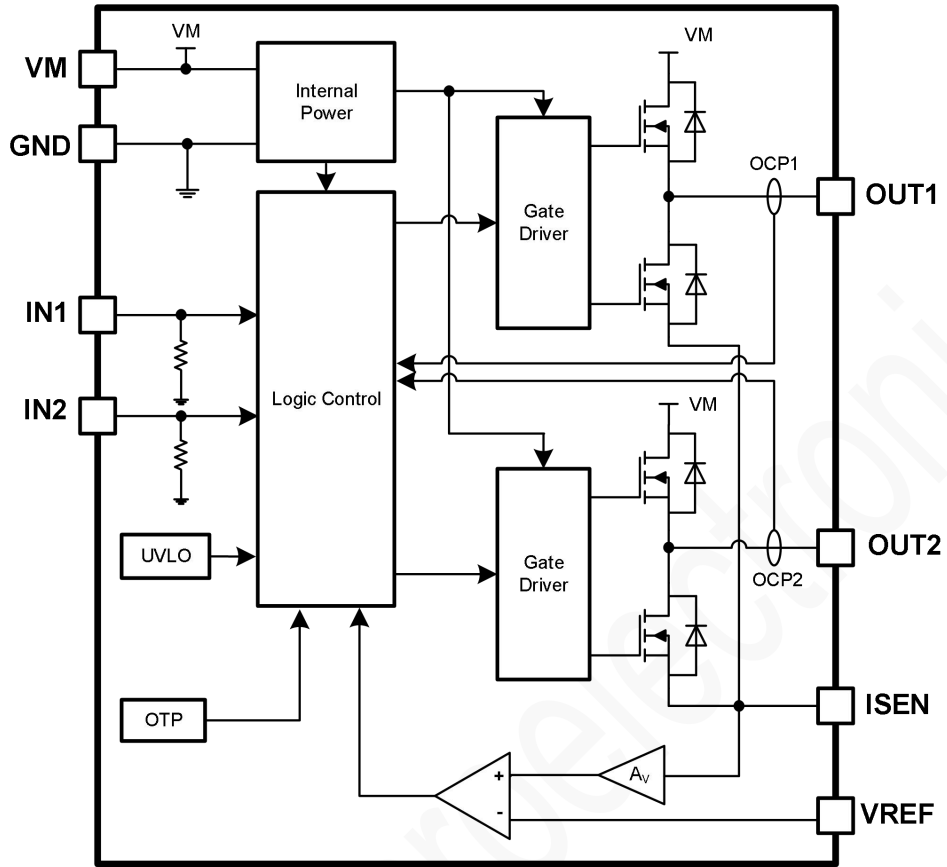
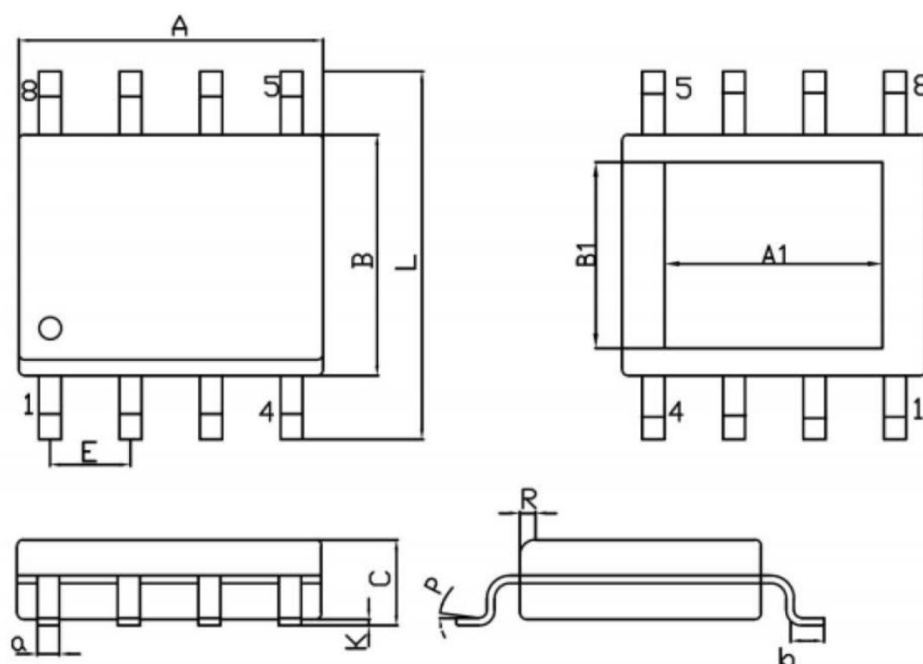

Figure 4. TMI8870/B Block Diagram

PACKAGE INFORMATION

ESOP8



Unit: mm

Symbol	Dimensions In Millimeters		Symbol	Dimensions In Millimeters	
	Min	Max		Min	Max
A	4.70	5.10	C	1.35	1.75
B	3.70	4.10	a	0.35	0.49
L	6.00	6.40	R	0.30	0.60
E	1.27 BSC		P	0°	7°
K	0.02	0.10	b	0.40	1.25
A1	3.1	3.5	B1	2.2	2.6

Note:

- 1) All dimensions are in millimeters.
- 2) Package length does not include mold flash, protrusion or gate burr.
- 3) Package width does not include inter lead flash or protrusion.
- 4) Lead popularity (bottom of leads after forming) shall be 0.10 millimeters max.
- 5) Pin 1 is lower left pin when reading top mark from left to right.

TAPE AND REEL INFORMATION

TAPE DIMENSIONS: ESOP8

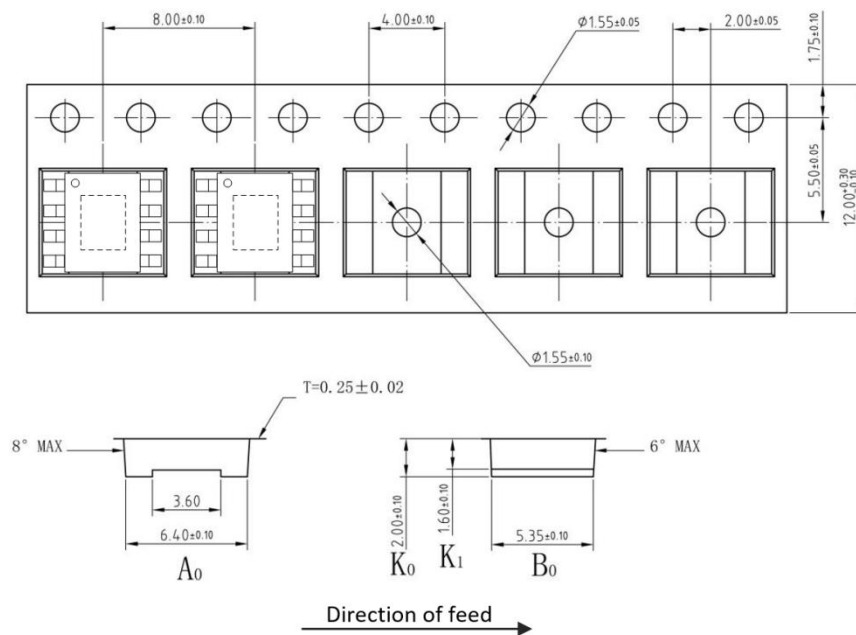

REEL DIMENSIONS: ESOP8

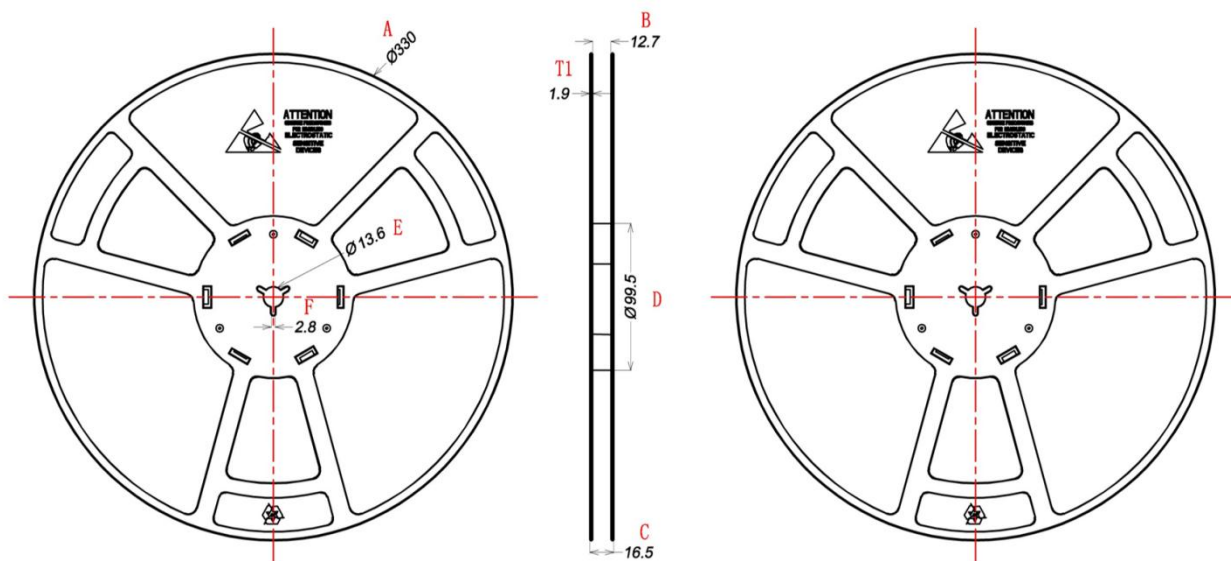

Unit: mm

A	B	C	D	E	F	T1
Ø 330±1	12.7±0.5	16.5±0.3	Ø 99.5±0.5	Ø 13.6±0.2	2.8±0.2	1.9±0.2

Note:

- 1) All Dimensions are in Millimeter
- 2) Quantity of Units per Reel is 3000
- 3) MSL level is level 3.

Important Notification

This document only provides product information. Xi'an TOLL Microelectronic Inc. (TMI) reserves the right to make corrections, modifications, enhancements, improvements, and other changes to its products and to discontinue any product without notice at any time.

Xi'an TOLL Microelectronic Inc. (TMI) cannot assume responsibility for use of any circuitry other than circuitry entirely embodied in a TMI product. No circuit patent licenses are implied.

All rights are reserved by Xi'an TOLL Microelectronic Inc.

[http:// www.toll-semi.com](http://www.toll-semi.com)