

GENERAL DESCRIPTION

The OPA348AIDBVR/OPA348AIDCKR is a CMOS operational amplifier that uses the proprietary auto-calibration technique to simultaneously provide very low offset voltage, near-zero drift over time and temperature. This miniature, high-precision, low quiescent current amplifiers offer high-impedance inputs that have a common-mode range 200mV beyond the rails, and rail-to-rail output that swings within 50mV of the rails, single or dual supplies as low as 2.1V ($\pm 1.35V$) and up to 5.5V ($\pm 2.75V$) can be used. This device is optimized for low voltage, single supply operation.

The OPA348AIDBVR/OPA348AIDCKR offers excellent CMRR without the crossover associated with traditional complementary input stages. This design results in superior performance for driving analog-to-digital converters (ADC) without degradation of differential linearity.

The OPA348AIDBVR / OPA348AIDCKR is available in the 5-pin SOT-23-5 and SC70-5 packages, and specified for operation from $-40^{\circ}C$ to $85^{\circ}C$.

FEATURES

- VDD range: 2.1V to 5.5V
- Low Offset Voltage: 0.5mV (Typical)
- Low Drift: 0.65 $\mu V/C$ (Typical)
- Low Noise
- Quiescent Current: 28 μA
- Rail to Rail Input/Output
- MicroSize Packages: SC70-5 and SOT23-5

Applications

- Transducers
- Temperature Measurement
- Electronic Scales
- Medical instrumentation
- Handheld Test Equipment

Reference News

PIN CONFIGURATION		Marking	
SOT-23-5	SC70-5	SOT-23-5	SC70-5

PIN DESCRIPTION

NAME	PIN		I/O	DESCRIPTION
	DBV (SOT-23)	DCK (SC70)		
-IN	4	3	I	Negative (inverting) input
+IN	3	1	I	Positive (noninverting) input
NC	—	—	—	No internal connection (can be left floating)
OUT	1	4	O	Output
V-	2	2	—	Negative (lowest) power supply
V+	5	5	—	Positive (highest) power supply

REEL SPECIFICATION

P/N	PKG	QTY
OPA348AIDBVR	SOT-23-5	3000
OPA348AIDCKR	SC70-5	3000

SIMPLIFIED SCHEMATIC

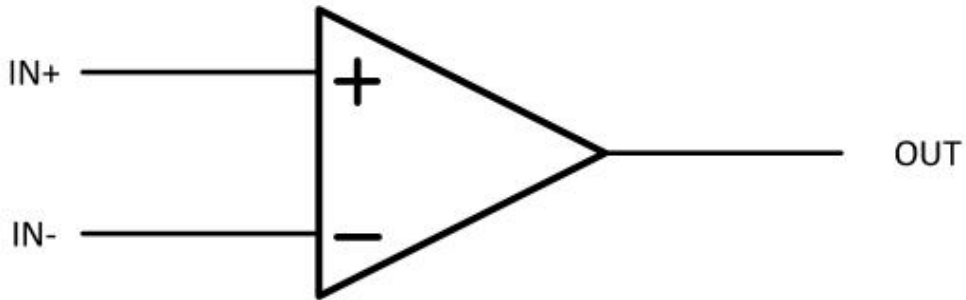

Figure 1.Simpliied Schematic

ABSOLUTE MAXIMUM RATINGS

Thermal Resistance 0 Jc..... 130°C/W
 Supply Voltage..... 2.1 to 5.5V
 Signal Input Terminals Voltage..... -0.1 to (V+) +0.1V
 Operating Junction Temperature 150°C
 Operating Temperature Range -40°C to 85°C
 Storage Temperature -65°C to 150°C

ELECTRICAL CHARACTERISTICS

(At TA=25° C, RL=10k connected to Vs/2, and Vour=Vs/2, unless otherwise noted.)

PARAMETER	CONDITIONS	MIN	TYP	MAX	UNIT
Input Offset Voltage	Vs=±2.5V	-3	0.5	3	mV
Input Offset Voltage Drift	TA=-40°C to 85°C		0.65		μV/°C
Power Supply Rejection Ratio	Vs =2.1V to 5.5V TA=-40°C to 85°C	80	90		dB
Input Bias Current	TA=25°C		2.0		pA
Input Offset Current			1.0		pA
Common-mode Voltage Range		(V-)-0.1		(V+)+0.1	V
Common-mode Rejection Ratio	V-)-0.1<Vcm<(V+)+0.1 TA=-40°C to 85°C	80	95		dB
Open Loop Voltage Gain	(V-)+100mV<Vo<(V+)-100mV, RL=10k TA=-40°C to 85°C	80	100		dB
Gain-bandwidth product	CL=120pF		1.5		MHz
Slew Rate	G=+1		1.2		V/μs
Specified Voltage Range		1.8		5.5	V
Quiescent Current			28	40	μA
Operating Temperature Range		-40		85	°C
Storage Temperature Range		-65		150	°C

TYPICAL PERFORMANCE CHARACTERISTICS

(At $T_A = 25^\circ\text{C}$, $V_S = 5\text{V}$, $C_L = 20\text{pF}$, unless otherwise noted.)

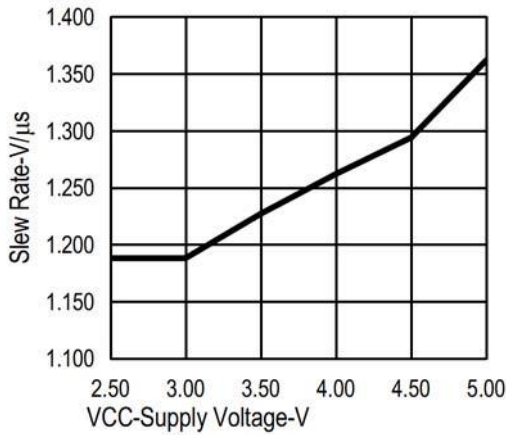

Figure 2. Slew Rate vs Supply Voltage

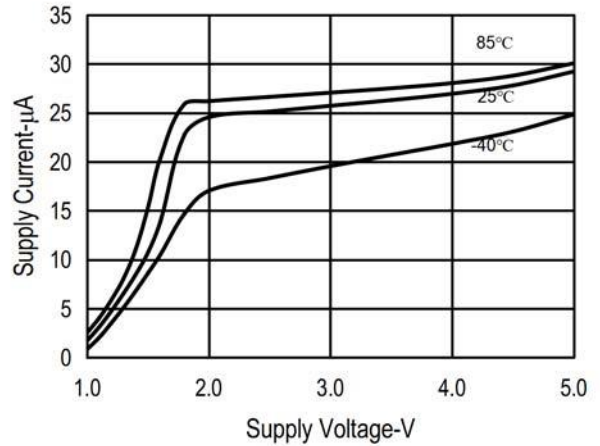

Figure 3. Supply Current vs Supply Voltage

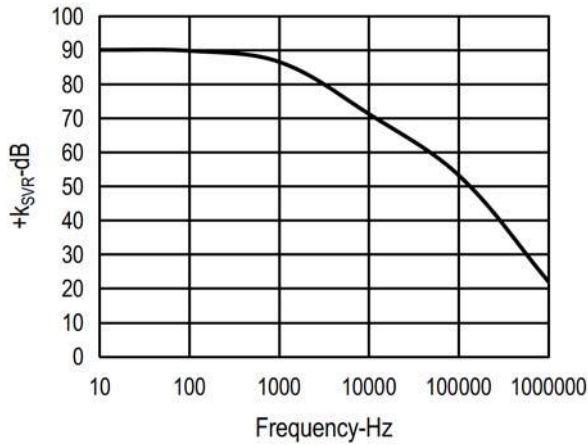

Figure 4. +kSVR vs Frequency

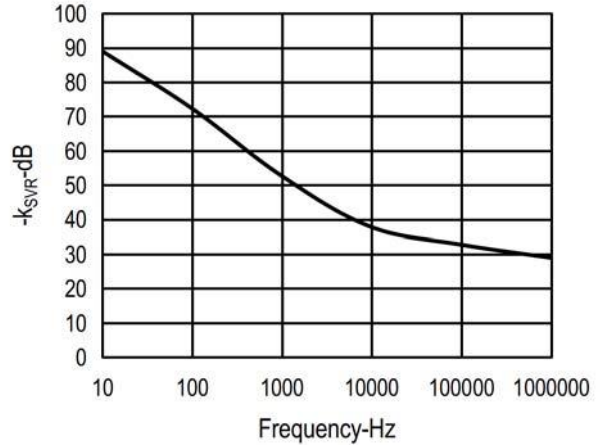

Figure 5. -kSVR vs Frequency

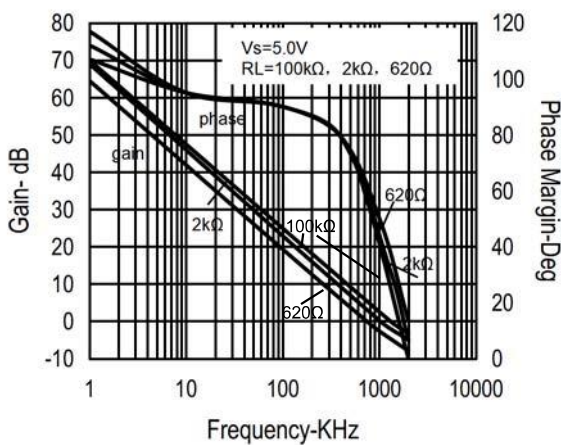

Figure 6. Frequency Response vs Resistive Load

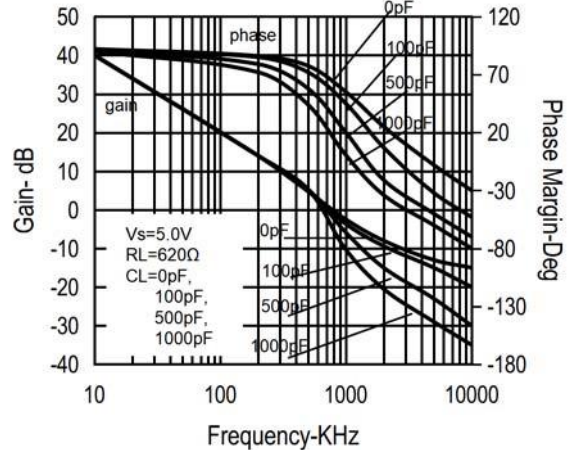

Figure 7. Frequency Response vs Capacitive Load

TYPICAL PERFORMANCE CHARACTERISTICS

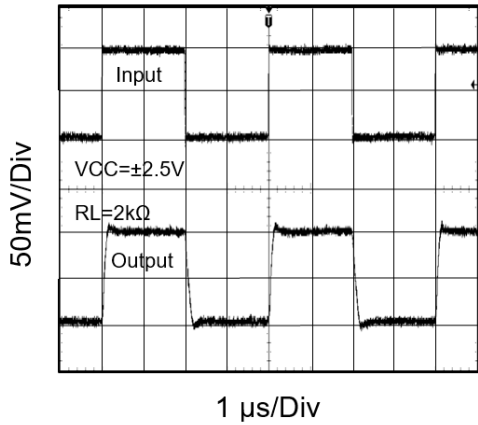

Figure 8. Noninverting Small-Signal Pulse Response

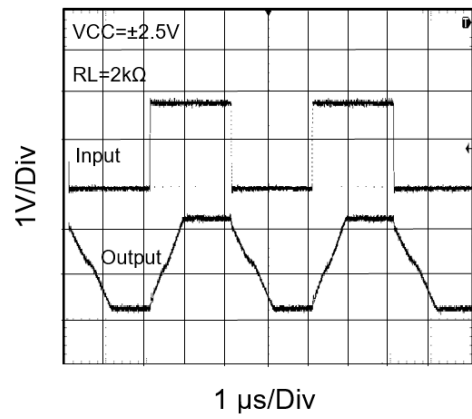

Figure 9. Noninverting Large-Signal Pulse Response

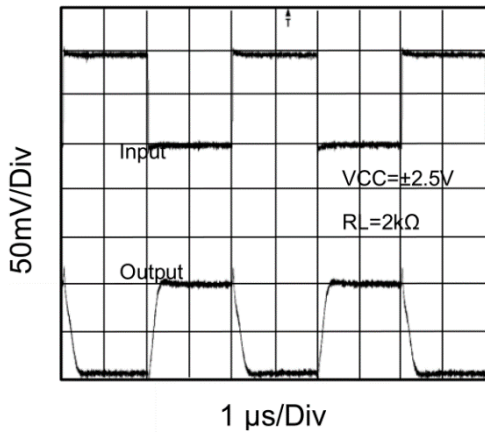

Figure 10. Inverting Small-Signal Pulse Response

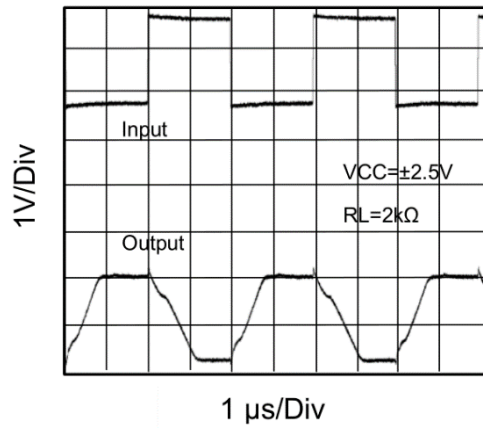

Figure 11. Inverting Large-Signal Pulse Response

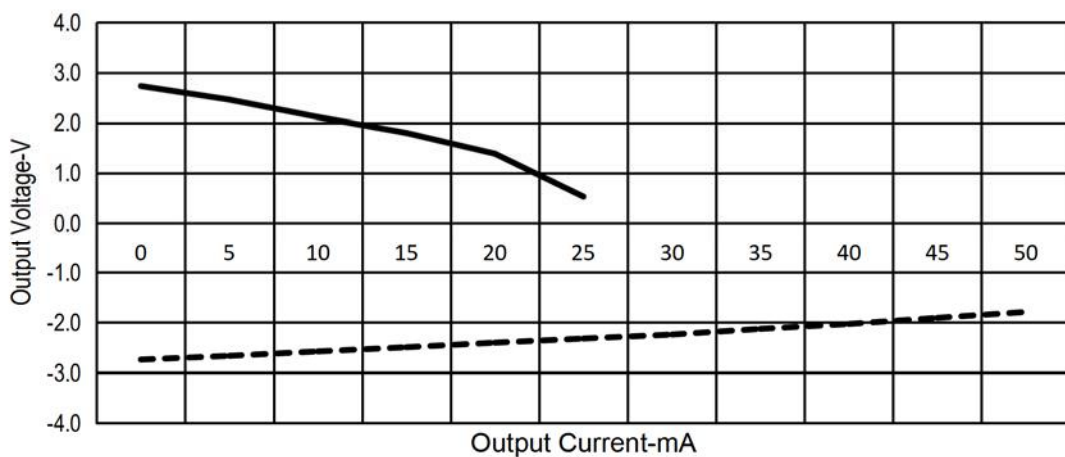

Figure 12. Output Voltage vs Output Current

FUNCTIONAL DESCRIPTION

Operating Voltage

The OPA348AIDBVR/OPA348AIDCKR devices are fully specified and ensured for operation from 2.1V to 5.5V. In addition, many specifications apply from -40°C to 85°C. Parameters that vary significantly with operating voltages or temperature are shown in the Typical Characteristics graphs.

Unity-Gain Bandwidth

The unity-gain bandwidth is the frequency up to which an amplifier with a unity gain may be operated without greatly distorting the signal. The OPA348AIDBVR/OPA348AIDCKR device has a 1.5-MHz unity-gain bandwidth.

APPLICATIONS INFORMATION

The OPA348AIDBVR/OPA348AIDCKR is a unity-gain stable, precision operational amplifier with very low drift; offset voltage these devices are also free from output phase reversal. Applications with noisy or high-impedance power supplies require decoupling capacitors close to the device power-supply pins. In most cases, 0.1µF capacitors are adequate.

Typical Application

Figure 13 shows a simple circuit to convert a single-ended input into differential output. The OPA348AIDBVR/OPA348AIDCKR could be used to build this circuit. The circuit is composed of two amplifiers. One amplifier acts as a buffer and creates a voltage, V_{out+} . The second amplifier inverts the input and adds a reference voltage to generate V_{out-} . Both V_{out+} and V_{out-} range from 0.5 to 2V. The difference, V_{DIFF} , is the difference between V_{out+} and V_{out-} .

Slew Rate

The slew rate is the rate at which an operational amplifier can change its output when there is a change on the input. The OPA348AIDBVR/OPA348AIDCKR devices have a 1.2 V/µs slew rate. The OPA348AIDBVR/OPA348AIDCKR is characterized to perform with this technique; the recommended resistor value is approximately 20k.

Device Functional Modes

The OPA348AIDBVR / OPA348AIDCKR device has a single functional mode. The device is powered on as long as the power supply voltage is between 2.1V ($\pm 1.35V$) and 5.5V ($\pm 2.75V$).

Detailed Design Procedure

Linearity over the input range is key for good dc accuracy. The common mode input range and the output swing limitations determine the linearity. In general, an amplifier with rail-to-rail input and output swing is required. Bandwidth is a key concern for this design. Because OPA348AIDBVR/OPA348AIDCKR has a bandwidth of 1MHz, this circuit will only be able to process signals with frequencies of less than 1 MHz.

Because the transfer function of V_{out} is heavily reliant on resistors ($R_1, R_2, R_3,$ and R_4) use resistors with low tolerances to maximize performance and minimize error. This design used resistors with resistance values of 36 k with tolerances measured to be within 2%. If the noise of the system is a key parameter, the user can select smaller resistance values (6 k or lower) to keep the overall system noise low. This ensures that the noise from the resistors is lower than the amplifier noise.

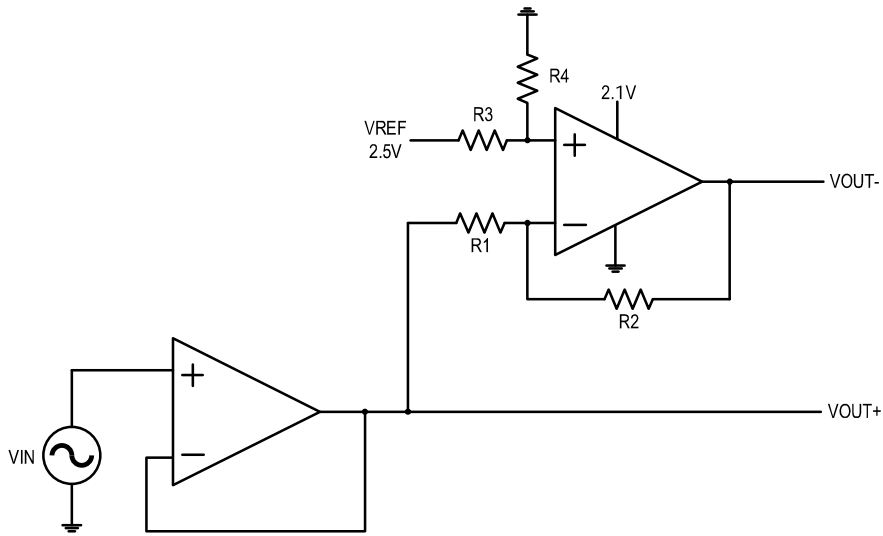
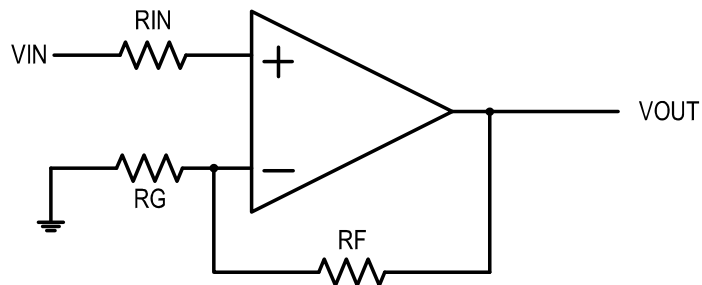

Figure 13. Schematic for Single-Ended Input to Differential Output Conversion

LAYOUT

Use good PCB layout practices for best operational performance of the device, including:

- Keep the length of input traces as short as possible.
- Run the input traces as far away from the supply lines as possible to reduce parasitic coupling.
- Place components close to device and to each other to reduce parasitic capacitance and parasitic errors.
- Use low-ESR, ceramic bypass capacitors to reduce the coupled noise by providing low impedance power sources local to the analog circuitry.
- Grounding for analog and digital portions of circuitry separately to suppress the noise.



Package Outline Dimensions (All dimensions in mm(inch).)

SC-70-5

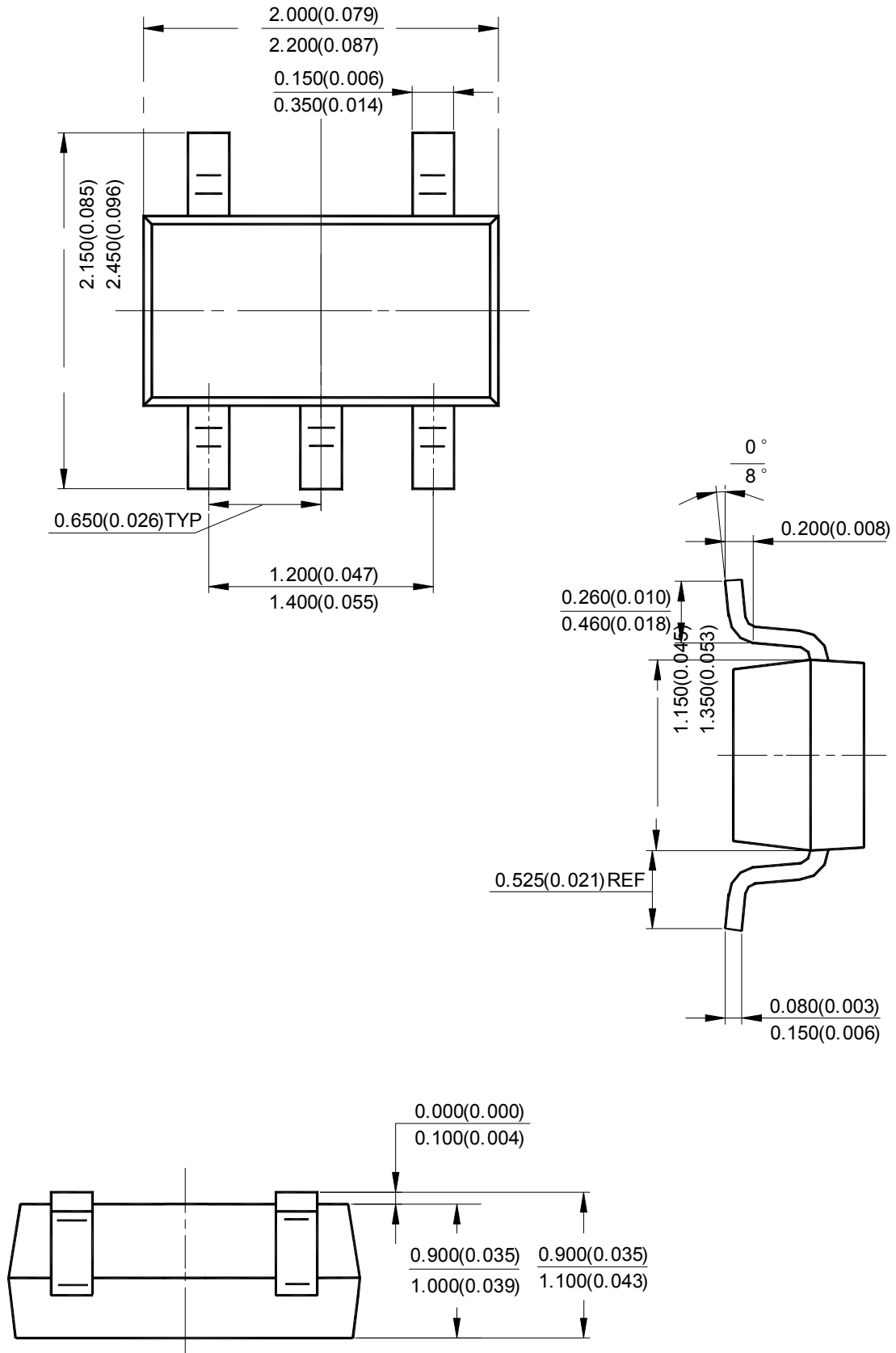

Package Outline Dimensions (Cont. All dimensions in mm(inch).)

SOT-23-5

