

STATE ELECTRONICS

Custom Potentiometer Designer Guide

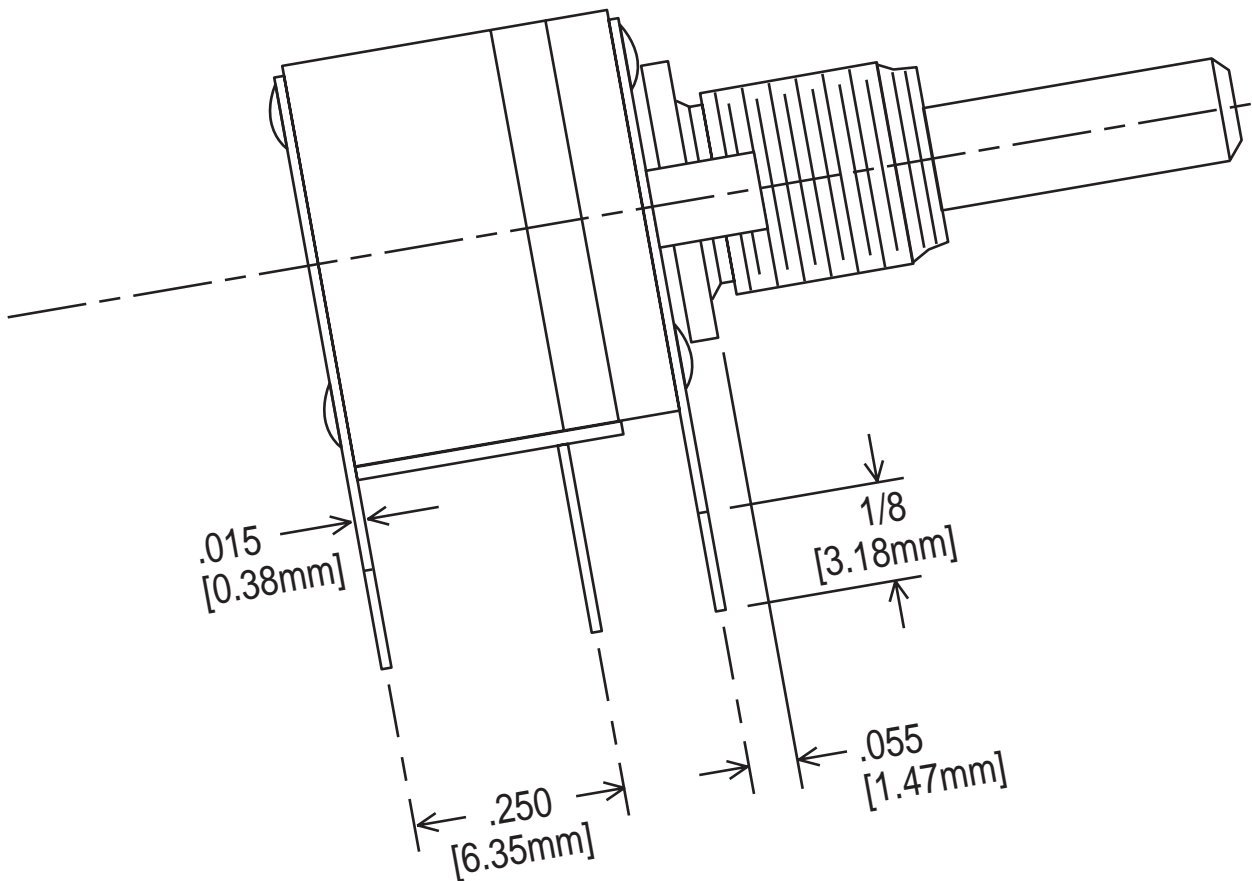

36 Route 10 • East Hanover • New Jersey • 07936

Phone 973-887-2550 • Toll Free 1-800-688-9711 • Fax 973-887-1940

Internet <http://www.potentiometers.com>

POT PROTOTYPES PRONTO!

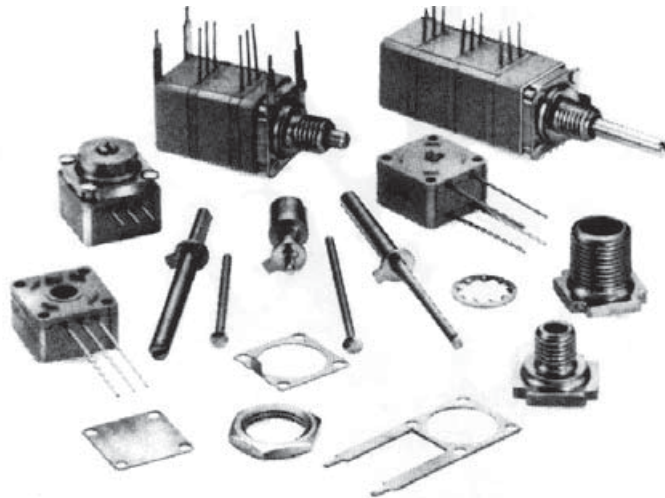

Now almost any special combination potentiometer you specify can be manufactured and shipped soon after your order is received.

Since Clarosystem and Mod Pot potentiometers are modular in construction, we can produce prototype quantities of 1/2 or 5/8 inch square, conductive plastic, cermet, or hot molded carbon pots for you in just a few hours . . . and even production quantities in a matter of days with our **VIP (Very Important Potentiometer)**SM service!

Over one billion combinations of single, dual, triple, quad arrangements, push-pull or rotary switches and hundreds of shaft terminal variations can be produced.

If you need a potentiometer and you need it fast, call our product manager or fax us your requirements using the Custom Potentiometer Order Forms included in this catalog.

WHY WAIT?

STATE
ELECTRONICS

36 Route 10
East Hanover, NJ 07936
Phone 973-887-2550
Toll Free 1-800-688-9711
FAX 973-887-1940
<http://www.potentiometers.com>

Series 70, 72, 73

Hot-Molded Carbon, Conductive Plastic (CP), and Cermet Panel Potentiometers



UNMATCHED FLEXIBILITY

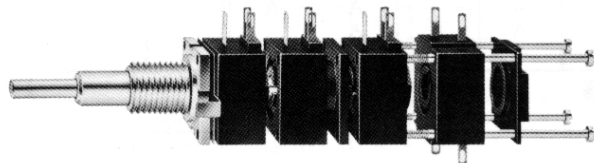

The MOD POT® Family includes:

- Series 70 – Metal or Plastic Shaft – Metal Bushing.
- Series 72 – Plastic or Metal Shaft – Plastic Bushing.
- Series 73 – Metal or Plastic Shaft – Metal Bushing. (Obsolete)

Features

- **Modular Construction**
- **Multiple Sections/Concentric Shafts**
- **Many Rotary and Push-Pull Switch Options**
- **Attenuators**
- **Linear and Non-Linear Tapers**
- **50 Ohms to 10 Megohms**
- **0.625 Inch (15,87 mm) Square**
- **Three Shaft Diameters**
- **Metal and Plastic Shafts**

Benefits

- **Versatility**
- **Versatility**
- **Versatility**
- **Versatility**
- **Versatility**
- **Wide Resistance Range**
- **Moderate Size**
- **Versatility**
- **Versatility**

AVAILABILITY

Groupings

MOD POT® Panel Potentiometers are divided into two groups.

Standard components - These components (listed in the tables on Page 36 and 37) are stocked at our MOD POT Assembly Centers. MOD POT Potentiometers

made from these standard components are available at assembly lead times.

Custom components - All other components shown are available but do require both fabrication and assembly.

SPECIFICATIONS

General

Versatile Panel Potentiometer

The MOD POT® concept consists of standardized potentiometer modules that can be mixed and matched in over a billion combinations. Now, you can be far more imaginative with potentiometers because you can get special combinations with the ease of standards.

Allen-Bradley originated the modular potentiometer concept in response to requests from design engineers who wanted virtually unlimited variety in variable resistors for greatly increased design freedom

MOD POT® modules are 5/8 inch square by about 1/2 inch deep. This provides minimum center-to-center distance for compact panel mounting. You can gang resistance and switch modules in combinations of up to four modules. Select from a whole family of resistive elements, resistive values and tolerances, tapers, shafts, bushings, lug options and more. You get a virtually unlimited number of design options.

TEMPERATURE RANGE

Series	Module Type	Maximum Temp °C	Minimum Temp °C
70	Hot-Molded or Conductive Plastic	+120°	-55°
	Cermet	+150°	-55°
72	Hot-Molded, Conductive Plastic or Cermet	+100°	-55°
73	Hot-Molded, Conductive Plastic or Cermet	+120°	-55°
70, 72, 73	Vernier	+100°	-55°
70, 72, 73	Switches	+100°	-55°

Hardware – Hardware is: .250 inch (6,35 mm) diameter bushing: (1) M-4748; (1) M-4721; (1) M-4761 (M-4761 is supplied only with locking bushings)

32.375 inch (9.52 mm) diameter bushing: (1) M-2898; (1) M-2786; (1) M-3638 (M- 3638 is supplied only with locking bushings)

All hardware shipped in bulk — not assembled unless otherwise specified.

Mounting Torque (Series 72) – Torque applied to the mounting nuts should not exceed 7 inch-pounds (790 mN-m) for the .250 inch (6,35mm) diameter bushing or 14 inch-pounds (1580 mN-m) for the .375 inch (9,52 mm) diameter bushing.

Turning Torque – Initially, at 25°C, the potentiometer torque will be 0.5 inch-ounce (3.5 mN-m) minimum while the maximum is:

Style	TORQUE INCH-OUNCES (mN-m)	
	Cermet and Hot-Molded Elements	CP Elements
Single	3 (21)	1.5 (11)
Dual	6 (42)	2.5 (18)
Triple	8 (56)	3.5 (25)
Quad	10 (71)	4.5 (32)

The maximum additional torque required for the vernier drive is 10 inch-ounces (71mN-m) on inner, coarse adjustment shaft.

Stop Torque – Minimum of 4 inch-pounds (451 mN-m) except for the Series 72 with a .125 inch (3.18 mm) diameter shaft which is 2 inch-pounds (225 mN-m) minimum. Vernier drives have slip clutches.

Rotation –

Single	Rotation in Degrees	
	Total Electrical/ Mechanical ±5°	Effective (Nominal)
Potentiometers	300	260
Potentiometers and Rotary Switch	300	260
Potentiometers and Push-Pull Switches	305	260
Rotary Switches	25	–
Rotary Switches and Push-Pull Switches	30	–

Vernier drive – Two vernier drive modules are available with hot-molded, cermet, and conductive plastic modules. Through a gearing arrangement, the total rotation will be changed to 16 turns or 4 turns. A ratchet clutch is provided in place of fixed stops for the fine adjustment shaft. Series 70 and 73 variable resistors may have concentric shaftw. The inner concentric shaft (.078 inch (1.98 mm) diameter) may be used as a coarse adjustment shaft.

Enclosure – Dust and splash resistant. They are not immersion sealed.

Materials – Corrosion-resistant and essentially nonmagnetic. The shafts and bushings of the Series 72 are plastic.

Standard Marking – State Electronics part number and nominal total resistance are marked in two lines. Other marking possible.

Electrical

Total resistance tolerances – Hot-Molded, CP: +/-10% or +/- 20%; Cermet: +/- 5% or +/- 10%.

POWER

Series	Power in Watts per Section		
	Hot-Molded at 70° C	Cermet at 70° C	CP at 70° C
70 (single)	1.0	2.0	.5
70 (multi-section)	.5	1.0	.25
72 (single)	.5	1.0	.25
72 (dual)	.5	.5	.25
73 (single)	1.0	2.0	.5
73 (multi-section)	.5	1.0	.25

Power derating – Derate power linearly from rated temperature to zero at maximum temperature. Derate power 50 percent for non-metallic mounting. Derate 60 percent for CP elements with “A” and “B” tapers.

Derate 50 percent for hot-molded elements with “A”, “B”, “S”, and “DB” tapers. For rheostat applications, derate power directly with shaft or actuator position.

Operational

Contact resistance variation – linear taper – Maximum value is: Hot-Molded & Cermet - 1.5 percent of nominal resistance value or 1.5 ohms, whichever is greater. CP - 1.0 percent of nominal resistance value.

Load Life – Maximum change in total resistance as a result of a 1000 hour test at rated power across entire element at +70° C (1.5 hours “ON”, 0.5 hour “OFF”) 5 percent for cermet element, 10 percent for hot-molded and CP elements

Environmental

Vibration – 2 percent maximum change in total resistance, 5 percent maximum change in resistance setting. (Tested per method 204, condition “C” of MIL-STD-202.)

Shock – 2 percent maximum change in total resistance, 5 percent maximum change in resistance setting. (Tested per method 213, condition “I” of MIL-STD-202.)

Humidity – Maximum change in total resistance as a result of 95 percent humidity at 40°C for 100 hours: 5 percent for cermet element, 10 percent for hot-molded and CP elements.

Temperature cycling – 3 percent maximum change in total resistance as a result of the temperature cycling test. (Five cycles at –55° C to the maximum temperature.)

Effect of soldering – Maximum change in total resistance as a result of immersing the terminals in

Voltage – 350 volts maximum working voltage (RMS or DC), or as determined by $E_{max} = \sqrt{PR}$, whichever is less (at sea level).

ATTENUATORS – HOT MOLDED

Series	Bridged-T	L	Bridged-H	Straight-T
70	A	A	A	A
72	A	A	NA	NA
73	A	A	A	A

Consult factory for further details

A=Available

NA=Not Available

Linearity – ±5 percent independent for linear tapers with a total resistance up to 1.0 megohm.

Dielectric withstanding voltage – Maximum continuous voltage, 350 volts (RMS) at sea level.

Will withstand a one second test of 1000 volts (RMS) at sea level or 500 volts (RMS) at 3.4 inches (86.36) mercury.

Insulation resistance – 1000 megohms minimum for clean and dry conditions at +25 °C.

Rotational life – 10 percent maximum change in total resistance as a result of a 100,000 mechanical cycle life test without load.

350° C solder to within 0.125 inch (3,18mm) of the resistor body for 5 seconds: 1 percent for cermet element, 2 percent for hot-molded and CP elements.

Low temperature operation – Maximum change in total resistance as a result of the low temperature operation test (–55°C for two hours without load and 45 minutes with rated load): 2 percent for cermet element; 3 percent for hot-molded and CP elements.

High temperature exposure – Maximum change in total resistance as a result of the high temperature exposure test (maximum rated temperature for 1000 hours without load): 4 percent for cermet element; 10 percent for hot-molded and CP elements.

Washability – MOD POT® performance may be adversely affected if subjected to conventional after-solder boardwash processes.

Environmental (continued)

Temperature characteristics – Maximum percent temporary total resistance change from the +25° C value. See chart below.

Nominal Resistance in Ohms	CP — “U” Linear Taper. °C							
	-55°	-25°	0°	+25°	+55°	+85°	+100°	+120°
100	-9.0	-6.0	-3.0	0	+3.5	+6.5	+8.0	+10
1K	±5.5	±3.0	±1.5	0	±1.5	±3.0	±4.0	±5.0
10K	+5.0	+3.0	±1.5	0	±2.0	±2.0	±2.5	±3.0
100K	+5.0	+3.0	±1.5	0	±2.0	±2.0	±2.5	±3.0
1.0 Meg	+6.0	+3.0	±2.0	0	±2.5	±3.0	±4.0	±5.0

Nominal Resistance in Ohms	HOT MOLDED — “U” Linear Taper. °C							
	-55°	-25°	0°	+25°	+55°	+85°	+100°	+120°
100	+4.5	+2.5	+1.5	0	±1.0	±1.5	+2.0	+3.5
1K	+5.5	+3.0	+1.5	0	±1.5	±2.0	+2.5	+4.5
10K	+7.0	+3.5	+2.0	0	±1.0	±2.5	+3.0	+5.5
100K	+8.0	+4.0	+2.0	0	±1.5	±3.0	+3.5	+6.0
1.0 Meg	+10.0	+5.0	+2.5	0	±1.5	±3.5	±5.0	+7.5

For “S”, “A” and “DB” tapers multiply percentage figures shown above by 1.25

Tapers

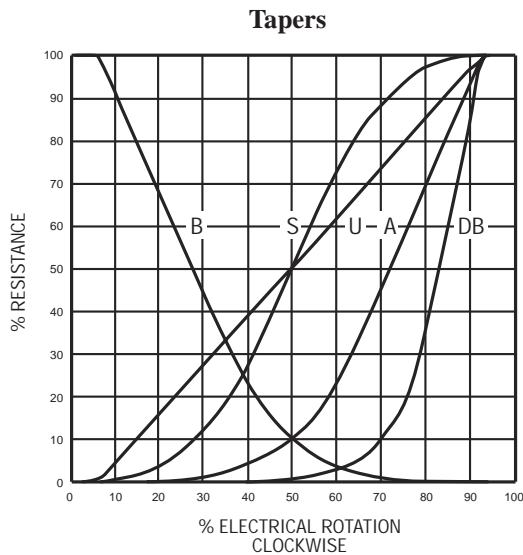

Tapers A, DB, S and U are measured between the wiper and the counter-clockwise terminals;
Taper B is measured between the wiper and the clockwise terminals.

Tapers – Available in the following resistance ranges:

UNIT	TAPER	TOTAL RESISTANCE RANGE
Hot-Molded	U	50 Ohms to 10.0 Megohms
	A, B, S & DB	250 Ohms to 10.0 Megohms
Cermet	U	100 Ohms to 5.0 Megohms
CP	U	100 Ohms to 1.0 Megohm
	A & B	250 Ohms to 1.0 Megohm

Temperature coefficient – For cermet linear taper elements, temperature coefficient less than ± 100 ppm/°C.

End Resistance –

TAPER	Minimum Resistance Between Terminals:					
	Hot-Molded		CV		Cermet	
	1 & 2	1 & 2	1 & 2	1 & 2	1 & 2	1 & 2
U	1	1	4	4	4	4
S	1	1	—	—	—	—
A	1	2	4	4	—	—
B	2	1	4	4	—	—
DB	3	2	—	—	—	—

- 1 Less than 0.004 percent of total resistance or less than 4 ohms, whichever is greater.
- 2 Less than 1 percent of total resistance or less than 4 ohms, whichever is greater.
- 3 Less than 4 ohms
- 4 Less than 2 ohms

Taps – A single electrical tap is available on hot-molded modules with lug terminals at 50 percent ± 3 percent of mechanical rotation. Specified nominal tap resistance tolerance ± 20 percent. Unless otherwise specified low series tap resistance is provided. See dimensions on page 42.

Switches

Rotary Switch – Maximum percent temporary total resistance change from the +25° C value. See chart below.

Rotary Switch – The rotary switch consists of two sets of contacts. See Part Number Explanation for available options. When supplied on the Series 72, the rotary switch must be used with a .250 inch (6,35 mm) diameter shaft.

Push-pull switch – A four pole switch that is operated by a .125 inch (3,18mm) diameter solid shaft. An inner concentric shaft that operated the push-pull switch only may have a diameter of .125 inch (3,18mm) or .078 inch (1,98mm). Shaft lengths are measured from the bushing mounting surface to the free end of the shaft with the shaft in the extended position. Available only on Series 70 and 73 (obsolete)

Momentary push switch – A push-pull switch equipped with a return spring such that the switch will return to the extended position when the actuating force is removed. Available only on Series 70 and 73.

Ambient temperature – -55° C to +100° C

Life – The switches will be electrically and mechanically operative after operational life test at rated current and voltage with a resistive load, per switch characteristics below.

Terminals – Switches are available with lug terminals only. They are not available with square terminals. On request, switches will be rotated 90° such that the switch terminals come out the sides of the control instead of the top and bottom.

PUSH-PULL AND MOMENTARY SWITCHES

Switch Number	Type	Voltage in Volts at 60 Hz RMS	Current in Amps	Actuating Force	Length of Throw		Operational Life
					Shaft Operates Switch and Pot	Shaft Operates Switch Only	
3001	Push-Pull	125	2	7 ounces (1.9N) Min. 19 ounces (5.3N) Max.	.125 Inch (3.18mm)	.125 Inch (3.18mm)	25,000
3002	Momentary Push	125	2	20 ounces (5.6N) Min. 30 ounces (8.3N) Max.	.125 Inch (3.18mm)	.125 Inch (3.18mm)	25,000

ROTARY SWITCHES

Switch Number	Detent at	In Detent		Voltage in Volts at 60 Hz RMS	Current in Amps	Actuating Torque	Length of Throw		Operational Life
		Terminals 1 and 2 are:	Term 3 and 4 are:				Shaft Operates Switch and Pot	Shaft Operates Switch Only	
1001	CCW end	Open	Closed	125	2	Med	15°	25°	25,000
1003	CCW end	Open	Open	125	2	Med	15°	25°	25,000
2001	CW end	Open	Closed	125	2	Med	15°	25°	25,000
2003	CW end	Open	Open	125	2	Med	15°	25°	25,000
1BT1 ■	CCW end	Open	Closed	125	.1	Low	15°	25°	5,000
				1	.01				
1BT3 ■	CCW end	Open	Open	125	.1	Low	15°	25°	5,000
				1	.01				
2BT1 ■	CW end	Open	Closed	125	.1	Low	15°	25°	5,000
				1	.01				
2BT3 ■	CW end	Open	Open	125	.1	Low	15°	25°	5,000
				1	.01				

Med Actuating Torque = Maximum of 20 inch-ounces (5.6 N)

Low Actuation Torque = Maximum of 7.5 inch-ounces (53 mN-m). Minimum of 3.5 inch-ounces (24.7 mN-m)

■ For use with conductive plastic element modules only.

Rotary Switches

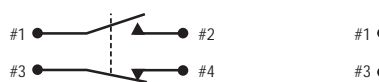

Switch Number
1BT1, 1001, 2BT1 or 2001
Shown in Detent

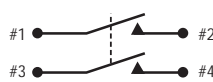

Switch Number
1BT3, 1003, 2BT3 or 2003
Shown in Detent

Push-Pull or Momentary Push Switch

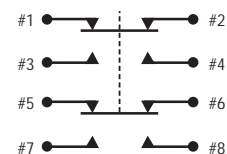

Switch Number
3001 or 3002
With Shaft Extended

MOD POT® SERIES 70,72,73

Hot-Molded Carbon, Conductive Plastic (CP), and Cermet Panel Potentiometers

Explanation of Part Numbers

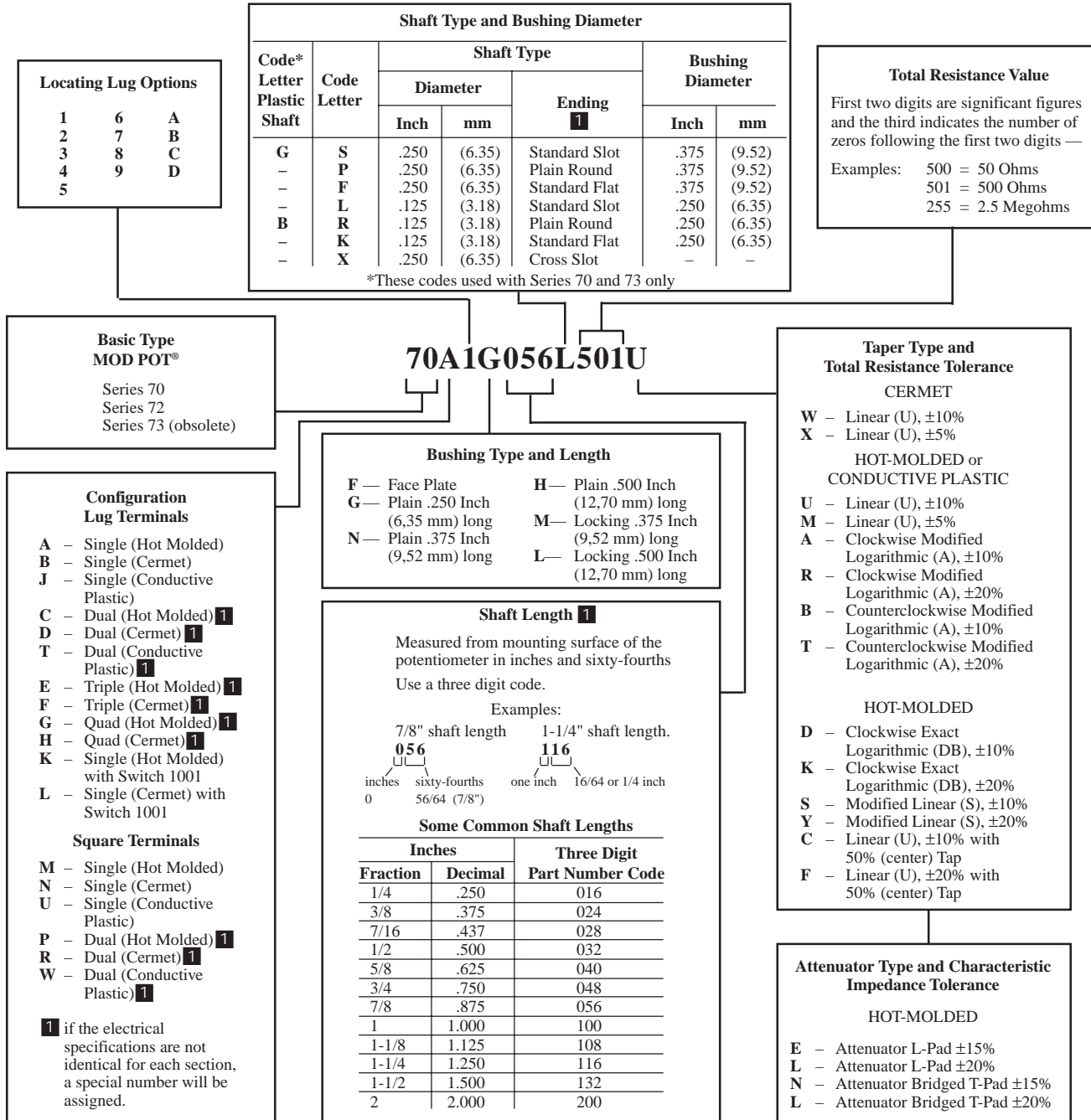

1 CONCENTRIC AND SPECIAL SHAFTS REQUIRE SPECIAL PART NUMBER ISSUED BY THE FACTORY.

CAUTION: Not all part number combinations are valid. Check parameter limits in text.

EXAMPLE: 70A1N024P501U
Invalid Bushing/Shaft Combination
Plain .375 inch (9.52 mm) long bushing with
plain .375 inch (9.52 mm) long shaft.

Basic Combinations

The MOD POT® Potentiometer is available in single, dual, triple, and quadruple construction. This includes potentiometer, switch and vernier drive modules. The table below lists some of the options available for single

and multi-section controls. Because of the versatility of the MOD POT® Potentiometer, many other options are available. Momentary push switches may be used in place of push-pull switches in the listed combinations.

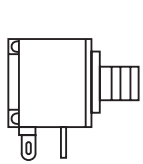

Single Unit

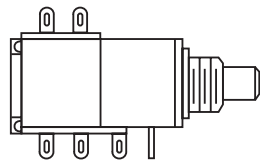

Dual Unit

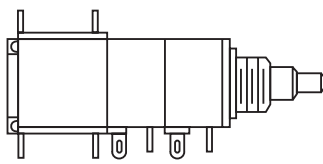

Triple Unit

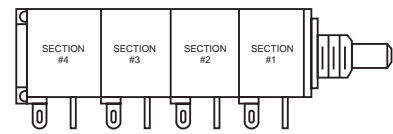

Quad Unit

	Section #1	Section #2	Section #3	Section #4	Drawing ■	Series			See Note
						70	72	73	
Single Unit	Potentiometer				1A	A	A	A	
	Rotary Switch				2A	A	A	A	4
	Push-Pull Switch				3A	A	NA	A	
Dual Unit Single Shaft	Potentiometer	Potentiometer			4A	A	A	A	
		Rotary Switch			5A	A	A	A	4
		Push-Pull Switch			5B	A	NA	A	
	Vernier Drive	Potentiometer			6A	A	A	A	
Dual Unit Concentric Shaft	Potentiometer	Potentiometer			7A	A	NA	A	
		Push-Pull Switch			8A	A	NA	A	
		Rotary Switch			9B	A	NA	A	
	Vernier Drive	Potentiometer			10A	A	NA	A	3
	Rotary Switch	Push-Pull Switch			11A	A	NA	A	
Triple Unit Single Shaft	Potentiometer	Potentiometer	Potentiometer		12A	A	NA	A	
			Push-Pull Switch		12B	A	NA	A	
		Rotary Switch	Push-Pull Switch		12C	A	NA	A	
		Potentiometer	Rotary Switch		13A	A	NA	A	
	Rotary Switch			13B	A	NA	A		
	Vernier Drive	Potentiometer	Potentiometer		14A	A	NA	A	
Triple Unit Concentric Shaft	Potentiometer	Potentiometer	Potentiometer		15A	A	NA	A	
			Rotary Switch		16A	A	NA	A	
			Push-Pull Switch		17A	A	NA	A	
	Rotary Switch		18A	A	NA	A			
	Vernier Drive	Potentiometer	Potentiometer		19A	A	NA	A	1 or 3
	Rotary Switch			20A	A	NA	A	1	
Quad Unit Single Shaft	Potentiometer	Potentiometer	Potentiometer	Potentiometer	23A	A	NA	A	
				Push-Pull Switch	23B	A	NA	A	
				Rotary Switch	23C	A	NA	A	
	Vernier Drive	Potentiometer	Potentiometer	Potentiometer	25A	A	NA	A	
Quad Unit Concentric Shaft	Potentiometer	Potentiometer	Potentiometer	Potentiometer	26A	A	NA	A	
				Rotary Switch	27A	A	NA	A	
	Rotary Switch			28A	A	NA	A	1	
	Potentiometer	Rotary Switch	Rotary Switch	29A	A	NA	A		
			Push-Pull Switch	30A	A	NA	A		
			Potentiometer	31A	A	NA	A		
	Vernier Drive	Potentiometer		Potentiometer	32A	A	NA	A	1,2, or 3
			Rotary Switch	33A	A	NA	A	1 or 2	

■ "Drawing" refers to dimensional drawings on Pages 41, 42, 43.

NOTES:

1. The outer shaft operates Sections #1 and #2.
2. The outer shaft operates Sections #1, #2, and #3.
3. The inner shaft (.078 [1.98 mm] diameter) is for the coarse adjustment, the outer shaft for the fine adjustment.
4. Series 72 must have .250 inch (6.35 mm) diameter shaft.

STANDARD RESISTANCE MODULES – LINEAR TAPER

Element Type		Hot-Molded Carbon		Cermet		Conductive Plastic			
Resistance Tolerance		10% or 20%		10%		10%		20%	
Taper		(U) or (M)		(W)		(U)		(M)	
Terminal Type		Lug	Pin	Lug	Pin	Lug	Pin	Lug	Pin
Resistance (ohms)	Code								
100	101	A	-	A	A	-	-	-	-
1,000	102	A	A	A	A	A	A	A	A
10,000	103	A	A	A	A	A	A	A	A
100,000	104	A	A	A	A	A	A	A	A
1,000,000	105	A	A	A	A	A	-	A	-
10,000,000	106	A	-	*	*	*	*	*	*
200	201	A	-	A	-	-	-	-	-
2,000	202	A	A	A	A	-	-	-	-
20,000	203	A	A	A	A	A	A	A	A
200,000	204	A	A	A	A	-	-	-	-
250	251	A	-	A	A	-	-	-	-
2,500	252	A	-	A	A	A	-	A	-
25,000	253	A	A	A	A	A	A	A	A
250,000	254	A	A	A	A	-	-	-	-
2,500,000	255	A	A	A	-	*	*	*	*
50	500	A	A	*	*	*	*	*	*
500	501	A	A	A	A	-	-	-	-
5,000	502	A	A	A	A	A	A	A	A
50,000	503	A	A	A	A	A	A	A	A
500,000	504	A	A	A	A	-	-	-	-
5,000,000	505	A	-	-	-	*	*	*	*

A = Available from Distributor Stock.
 - = Special order only. Contact factory for information.
 * = Not Available.

STANDARD RESISTANCE MODULES – NON-LINEAR TAPER

Element Type		Hot-Molded Carbon		Conductive Plastic		Hot-Molded Carbon		Conductive Plastic	
Resistance Tolerance		10%		10%		10%		10%	
Taper		(A)		(A)		(B)		(B)	
Terminal Type		Lug	Pin	Lug	Pin	Lug	Pin	Lug	Pin
Resistance (ohms)	Code								
100	101	*	*	*	*	*	*	*	*
1,000	102	A	A	-	-	A	-	-	-
10,000	103	A	A	A	A	A	A	A	-
100,000	104	A	A	-	-	A	-	A	-
1,000,000	105	A	A	A	A	A	-	A	-
200	201	*	*	*	*	*	*	*	*
2,000	202	-	-	-	-	-	-	-	-
20,000	203	A	A	-	-	-	-	-	-
200,000	204	A	-	-	-	-	-	-	-
250	251	-	-	-	-	-	-	-	-
2,500	252	-	-	-	-	A	-	-	-
25,000	253	A	A	-	-	A	A	-	-
250,000	254	A	-	A	-	-	-	-	-
2,500,000	255	-	-	*	*	A	-	*	*
500	501	A	-	-	-	-	-	-	-
5,000	502	A	A	A	-	A	-	-	-
50,000	503	A	A	-	-	A	A	A	A
500,000	504	A	A	A	-	A	-	-	-
5,000,000	505	A	-	*	*	A	-	*	*

A = Available from Distributor Stock.
 - = Special order only. Contact factory for information.
 * = Not Available.

STANDARD SHAFTS

Shaft Type	Used With	FMS Shaft Length	Shaft Ending	
			Plain	Slotted
Metal .250 (6,35 mm) Dia. Solid	.375 (9.52 mm) Dia. Bushing Series 70; 73	.375 (9,52 mm)	70	70
		.500 (12,70 mm)	70	B
		.625 (15,88 mm)	70	B
		.750 (19,05 mm)	70	B
		1.000 (25,40 mm)	–	73
Metal .125 (3,18 mm) Dia. Solid	.250 (6.35 mm) Dia. Bushing Series 70; 73	.375 (9,52 mm)	70	70
		.500 (12,70 mm)	70	B
		.625 (15,88 mm)	70	B
		.750 (19,05 mm)	70	B
		.875 (22,22 mm)	70	B
		1.000 (25,40 mm) 2.500 (63,50 mm)	–	73 70
Plastic .250 (6,35 mm) Dia. Solid	.375 (9.52 mm) Dia. Bushing Series 70; 72; 73	.375 (9,52 mm)	–	–
		.500 (12,70 mm)	–	–
		.625 (15,88 mm)	–	–
		.750 (19,05 mm)	–	A
		.875 (22,22 mm)	–	A
Plastic .125 (3,18 mm) Dia. Solid	.250 (6.35 mm) Dia. Bushing Series 70; 72; 73	.375 (9,52 mm)	–	–
		.500 (12,70 mm)	A	–
		.625 (15,88 mm)	A	–
		.750 (19,05 mm)	A	–
		.875 (22,22 mm)	–	–
Metal Outer Concentric	.375 (9.52 mm) Dia. Bushing Series 70; 73	.625 (15,88 mm)	B	–
		.750 (19,05 mm)	B	–
Metal Outer Concentric	.250 (6.35 mm) Dia. Bushing Series 70; 73	.625 (15,88 mm)	B	–
Metal Inner Concentric Standard for Dual Deck Constructions only	.250 (6.35 mm) Dia. Bushing or .375 (9,52 mm) Dia. Bushing Series 70; 73	1.125 (28,58 mm)	B	–

A = Available on Series 70, 72, 73 70 = Available on Series 70 only
 B = Available on Series 70, 73 73 = Available on Series 73 only
 – = Available as a Special Order only. Consult factory for information.

STANDARD SHAFTS

Switch Part Number	1001	1003	2001	2003	1BT1	1BT3	2BT1	2BT3	3001	3002
Type	Rotary	Rotary	Rotary	Rotary	Rotary	Rotary	Rotary	Rotary	Push Pull	Momentary Push

STANDARD BUSHINGS

Diameter	Type	Length		Series		
		Inches	Millimeters	70	72	73
—	Bushingless	See Note ■		NA	A	NA
	Plain	.250	6.35	A	A	A
.250 Inch (6.35 mm)	Locking	.375	9.52	A	NA	A
		.375	9.52	A	NA	NA
		.500	12.70	A	NA	NA
.375 Inch (9.52 mm)	Plain	.250	6.35	A	NA	A
		.375	9.52	A	A	A
	Locking	.500	12.70	A	NA	A
		.375	9.52	A	NA	NA
		.500	12.70	A	NA	NA

Mounting bushings are supplied with 32-NEF-2A thread. All bushing lengths are measured from the mounting face to the end of the bushing.

A = Available. NA = Not Available.

STANDARD SHAFT AND BUSHING COMBINATIONS

Shaft Type	Shaft Diameter in Inches	
	.375 (9,52 mm) Dia. Bushing	.250 (6,35 mm) Dia. Bushing
Solid or Outer	.250 (6,35 mm)	.125 (3,18 mm)
Concentric	.125 (3,18 mm)	.078 (1,98 mm)
Inner Concentric	Verniers .078 (1,98 mm)	(1,98 mm)

Series 72 shafts and bushings are plastic.

Series 73 bushings and standard shafts are die-cast alloy

■ No mounting bushing. Shaft is cross slotted for screwdriver actuation and is flush with faceplate. See dimensions on Page 43.

Ordering Information

1. Basic type (Series 70, Series 72, or Series 73)
2. Type of element (cermet, hot-molded or conductive plastic (CP)).
3. Type of terminals (resistor element only).
4. Number of sections.
5. Taper (each element on multi-section controls).
6. Total resistance value (each element on multi-section controls) in ohms.
7. Tolerance (each element on multi-section controls) percent.
8. Bushing type (plain or locking).
9. Bushing length in inches or millimeters.
10. Bushing diameter .375 inch (9.52mm) or .250 inch (6.35mm)
11. Shaft ending (plain, slotted or flatted).
12. Shaft length from mounting surface in inches or millimeters.
13. Shaft material: plastic or metal.
14. Switch type.
15. Vernier drive.
16. Locating lug option.
17. Mounting hardware.
18. Your part number, if any.
19. Marking requirement on the part.
20. Special features*

* Forward complete detailed specifications to the factory.

Cross-Reference Guide

Description	MOD POT®			BOURNS	
	Series 70	Series 72	Series 73	Model 80	Model 90
Multiple Sections	to 4 sections	to 2 sections	to 4 sections	to 4 sections	to 2 sections
Concentric Shafts	■	■ 1	■	■	
Rotary Switches	■	■	■	■	■
Push Switches	■	■	■		
Hot-Molded Carbon Element	■	■ 1	■		
Conductive Plastic Element	■	■	■	■	■
Cermet Element	■	■	■	■	■
All-Plastic Construction		■			
Vernier Drive Mechanism	■	■	■		
Attenuators	■	■	■	■	

■ = Available

Series 73 is obsolete

1 = Available only with metal shafts

DIMENSIONS

Switches and Potentiometers - Lug Terminals

2A

Rotary Switch

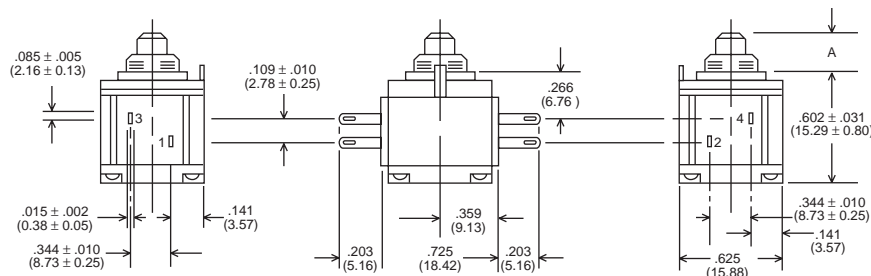

Basic Dimensions in inches.

Dimensions in parentheses are in millimeters.

TOLERANCE

Dimensional Tolerance

±.016 (0,40)

Except as Specified

Terminal numbers for reference ONLY

Module letters for reference ONLY

NOT TO SCALE

DIMENSIONS

Switches and Potentiometers – Lug Terminals (continued)

3A

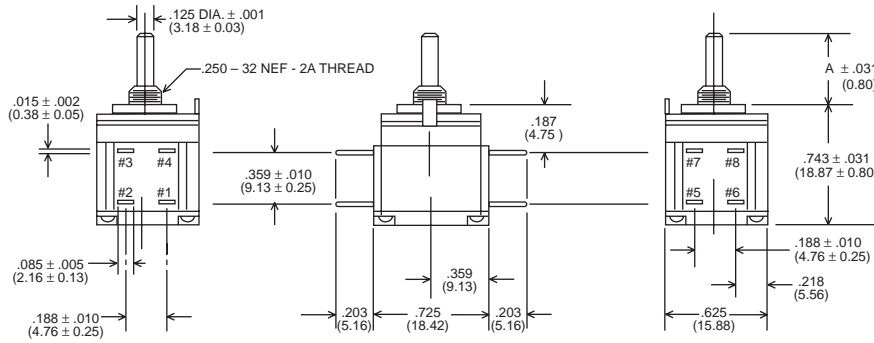

Push-Pull or Momentary Push Switch

5A

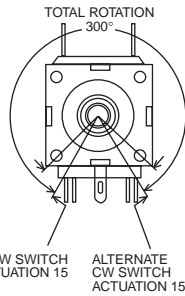
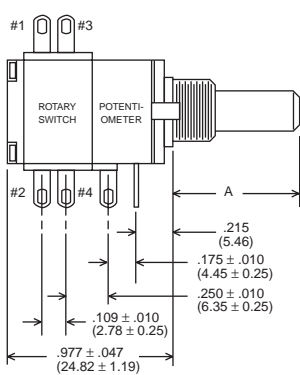

Dual Unit with Single Shaft

9A

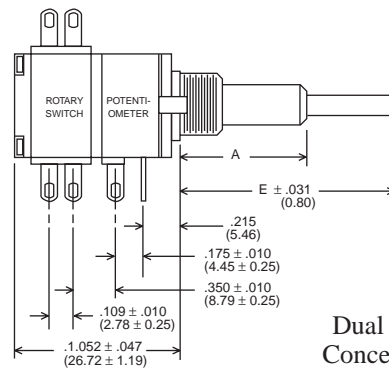

Dual Unit with Concentric Shaft

5B

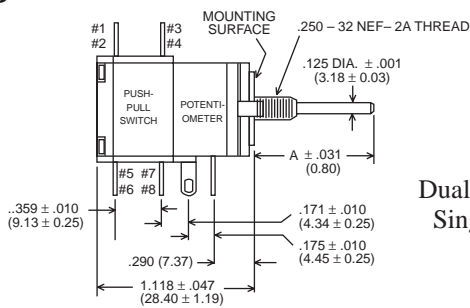

Dual Unit with Single Shaft

8A

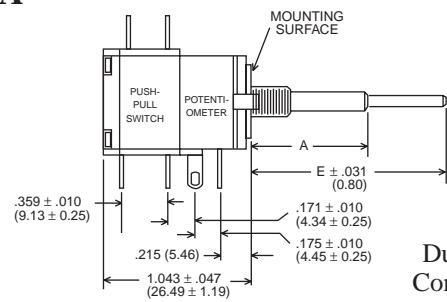

Dual Unit with Concentric Shaft

12C

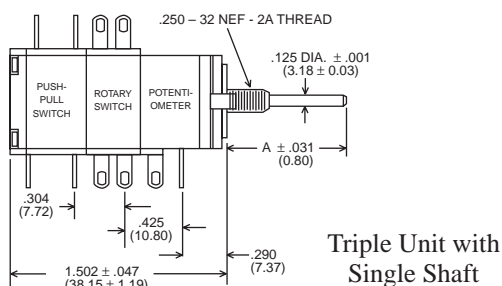

Triple Unit with Single Shaft

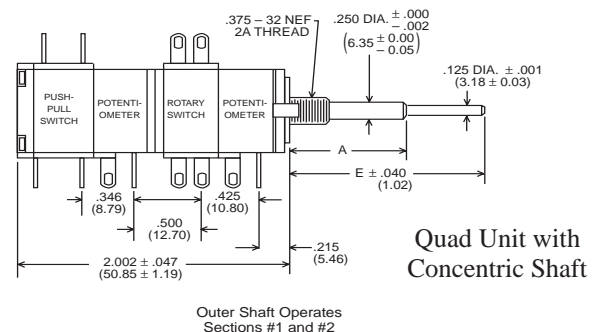

Quad Unit with Concentric Shaft

Outer Shaft Operates Sections #1 and #2

Potentiometers – Lug Terminals

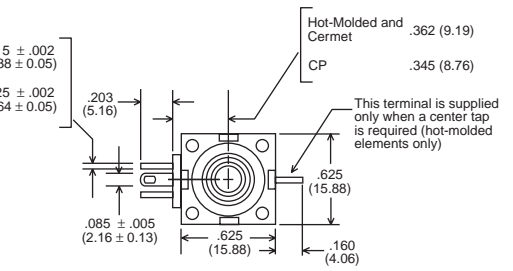
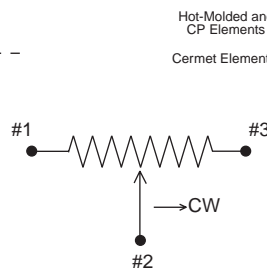
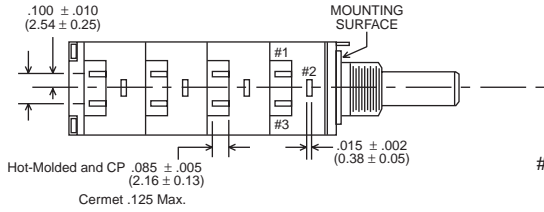

Basic Dimensions in inches.
Dimensions in parentheses are in millimeters.
TOLERANCE
Dimensional Tolerance $\pm .016$ (0.40) Except as Specified
NOT TO SCALE

Terminal numbers for reference only.
Terminal hole size: $.047 \pm .005 \times .078 \pm .005$
($1.19 \pm 0.13 \times 1.98 \pm 0.13$)

1A

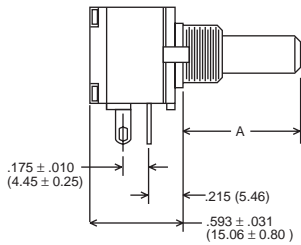

Single Unit
Single Shaft

12A

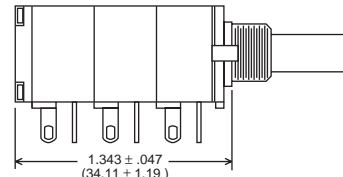

Triple Unit
Single Shaft

4A

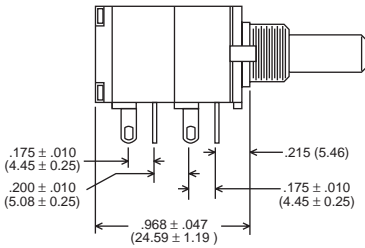

Dual Unit
Single Shaft

15A

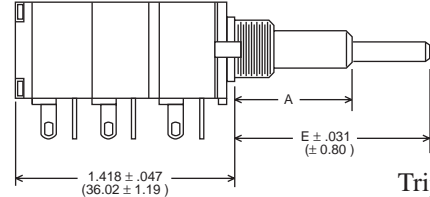

Triple Unit
Concentric Shaft

6A
10A

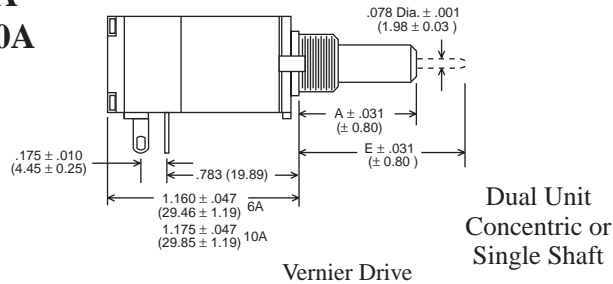

Dual Unit
Concentric or
Single Shaft

Vernier Drive

23A

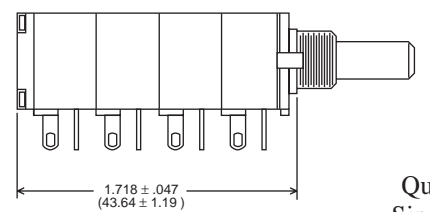

Quad Unit
Single Shaft

7A

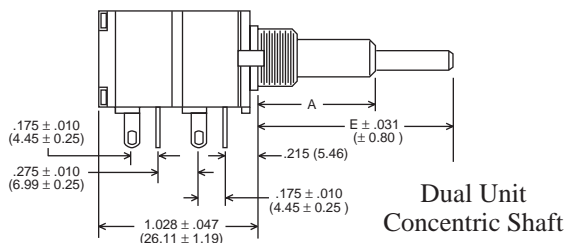

Dual Unit
Concentric Shaft

26A

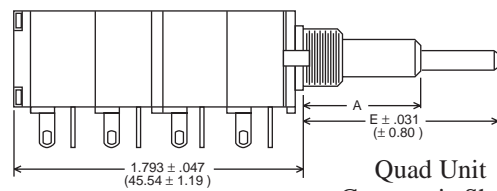

Quad Unit
Concentric Shaft
Outer Shaft Operates
Sections #1 & #2

Drawing numbers used for reference to a type of buildup only. This is not a part number.

DIMENSIONS

Potentiometers – Square Terminals

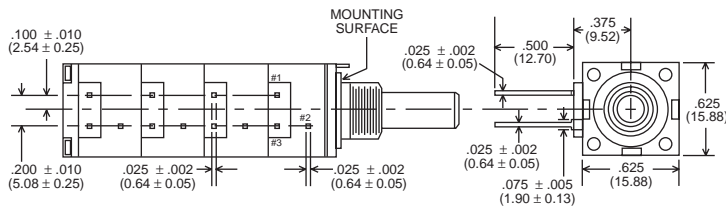

Basic Dimensions in inches.
Dimensions in parentheses
are in millimeters.
TOLERANCE
Dimensional Tolerance
 $\pm .016$ (0,40)
Except as Specified
NOT TO SCALE

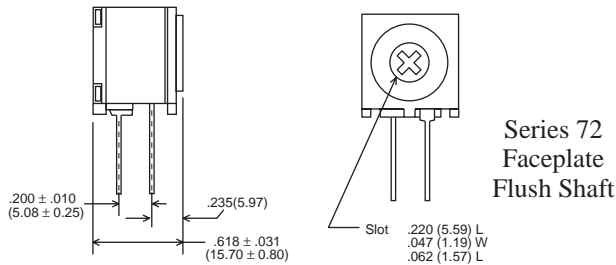
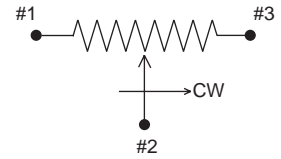

7A

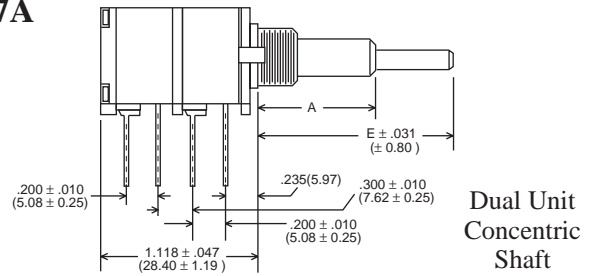

1A

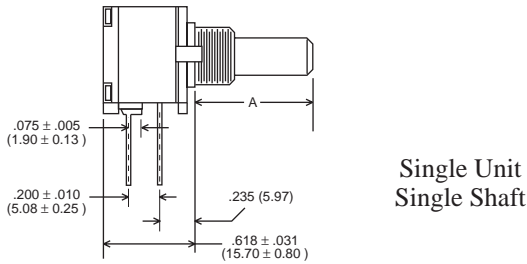

12A

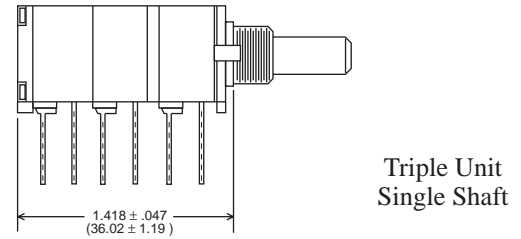

4A

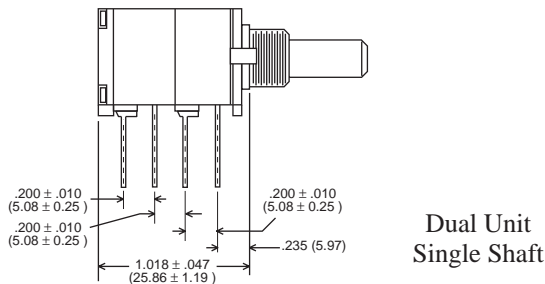

15A

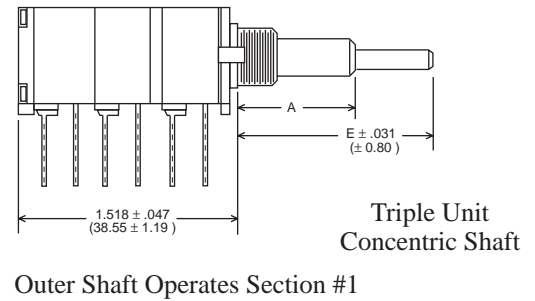

6A
10A

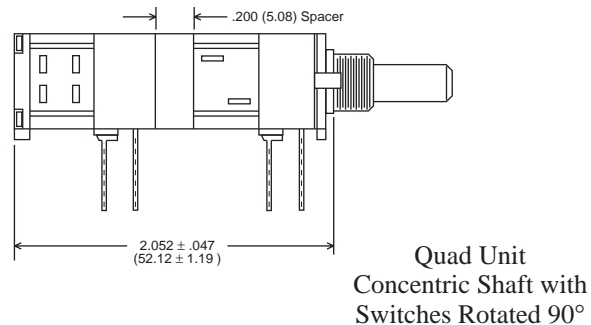
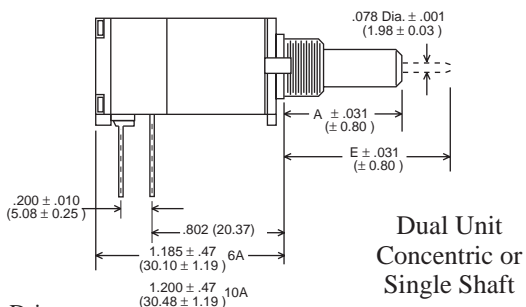

Vernier Drive

Drawing numbers used for reference to a type of buildup only. This is not a part number.

DIMENSIONS

Bushing, Shaft and Hardware Dimensions

.250 (6,35) DIAMETER BUSHINGS

Plain Bushing

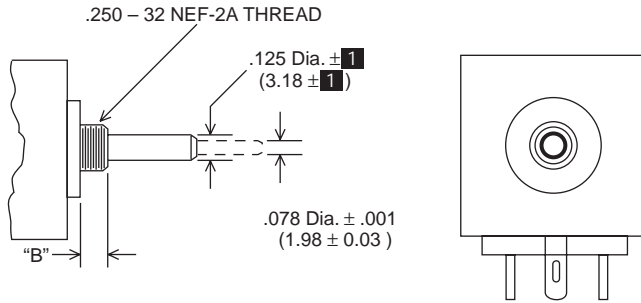

"B" STANDARD BUSHING LENGTHS .250 - .375 (6,35 - 9,53)

1 Tolerance - Series 70,73: ± 0.001 ($\pm 0,03$)
Series 72: $+0.001$ ($+0,03$), -0.003 ($-0,08$)

Locking Bushing

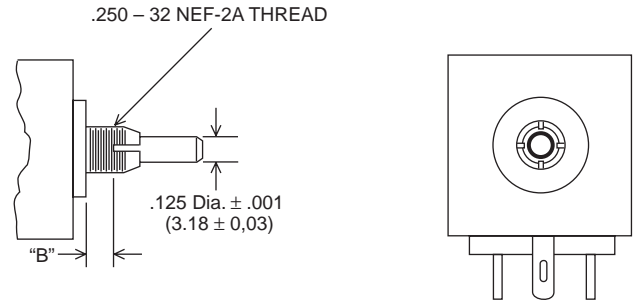

"B" STANDARD BUSHING LENGTHS .375-.500 (9,53-12,70)

MAXIMUM MOUNTING PANEL THICKNESS .062-.188 (1,59-4,76)
when used with one standard M-4748 Lock Washer
and one standard M-4721 Mounting Nut

Hardware

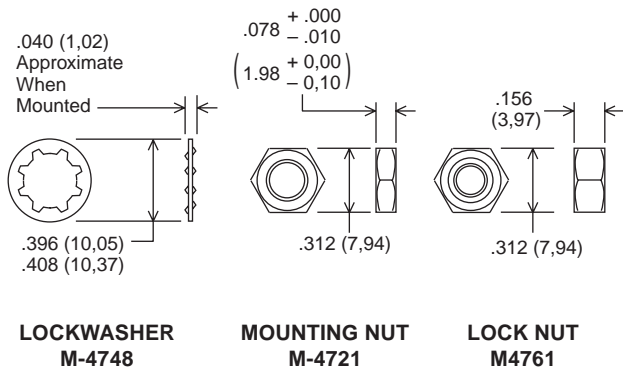

Standard Flatted Shaft

Shaft in extreme counterclockwise position. Angle applies to potentiometers only.

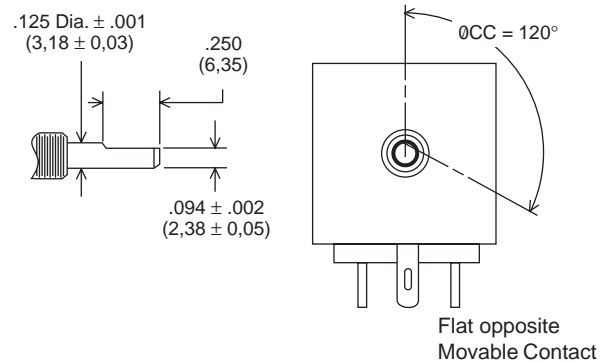

Flat will extend to within .031 (0,79) of mounting bushing where shaft length will not permit standard flat.

Standard Slotted Shaft

Shaft in extreme counterclockwise position. Angle applies to potentiometers only.

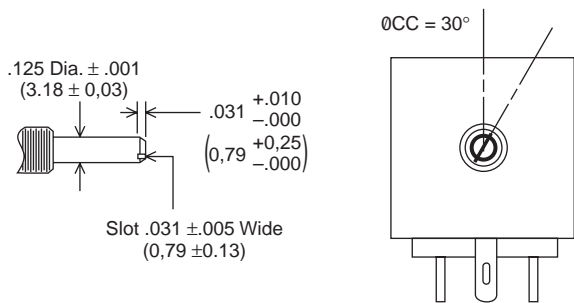

Screwdriver slot in line with Movable Contact

Concentric Shafts - Plain Ending

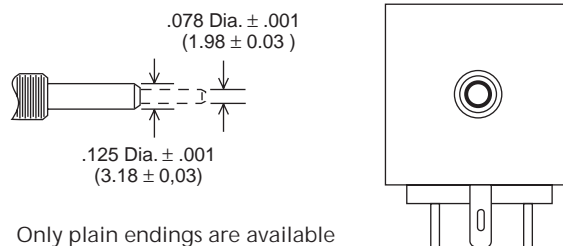

Only plain endings are available on these concentric shafts.

Basic Dimensions in inches.
Dimensions in parentheses are in millimeters.

TOLERANCE
Dimensional Tolerance ± 0.016 (0,40)
Angular Tolerance $\pm 5^\circ$, Except as Specified

DIMENSIONS

Bushing, Shaft and Hardware Dimensions

.250 (6,35) DIAMETER BUSHINGS

Plain Bushing

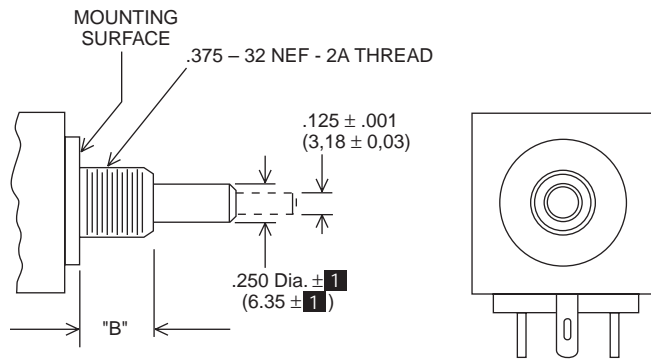

"B" STANDARD BUSHING LENGTHS .250 - .375 (6,35 - 9,53)

Locking Bushing

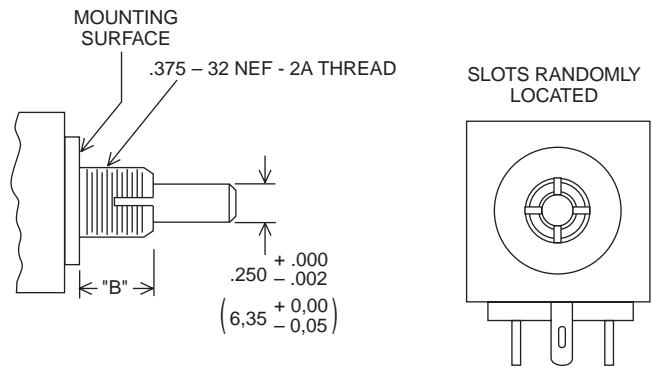

"B" STANDARD BUSHING LENGTHS .375-.500 (9,53-12,70)
 MAXIMUM MOUNTING PANEL THICKNESS .062-.188 (1,59-4,76)
 when used with one standard M-4748 Lock Washer
 and one standard M-4721 Mounting Nut

Hardware

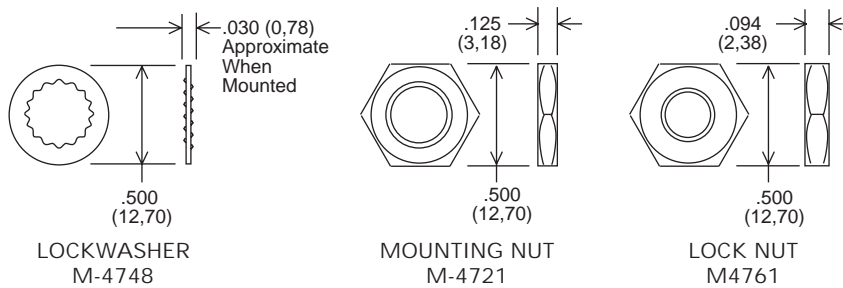

Basic Dimensions in inches.
 Dimensions shown in parentheses are in millimeters.
TOLERANCE
 Dimensional Tolerance $\pm .016$ (0,40)
 Angular Tolerance $\pm 5^\circ$, Except as Specified

Standard Flatted Shaft

Shaft in extreme counterclockwise position. Angle applies to potentiometers only.

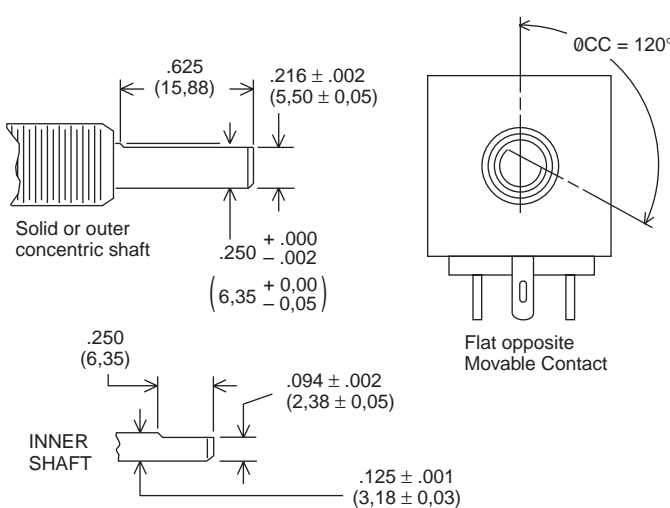

Flat will extend to within .031 (0,79) of mounting bushing where shaft length will not permit standard flat.

Standard Slotted Shaft

Shaft in extreme counterclockwise position. Angle applies to potentiometers only.

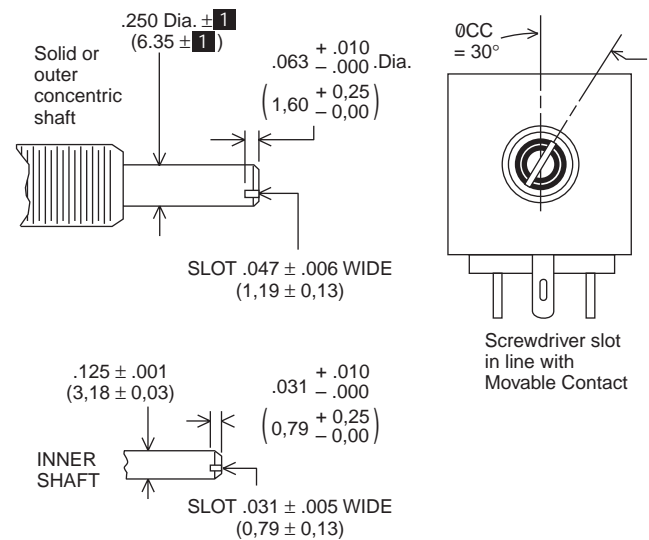

1 Tolerance - Series 70,73: $\pm .001$ ($\pm 0,03$)
 Series 72: $+.001$ ($+0,03$), $-.003$ ($-0,08$)

DIMENSIONS

Locating Lug Options – Series 70 **1**

Options 1, 2 and A

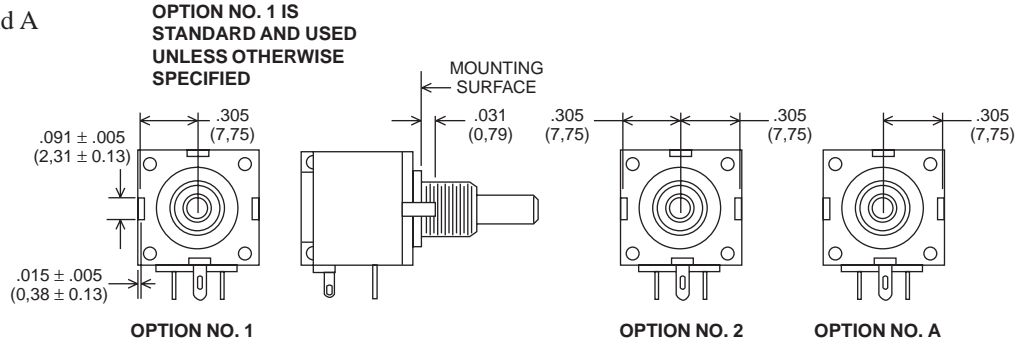

Options 3, 5 and B

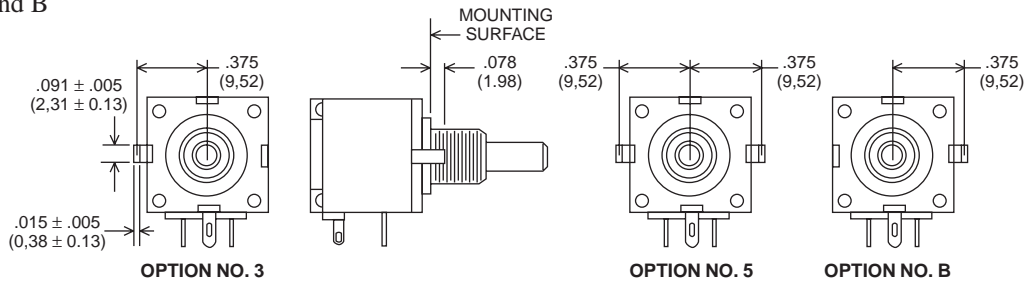

Locating Lugs Compatible With RV5

Options 6, 7 and C

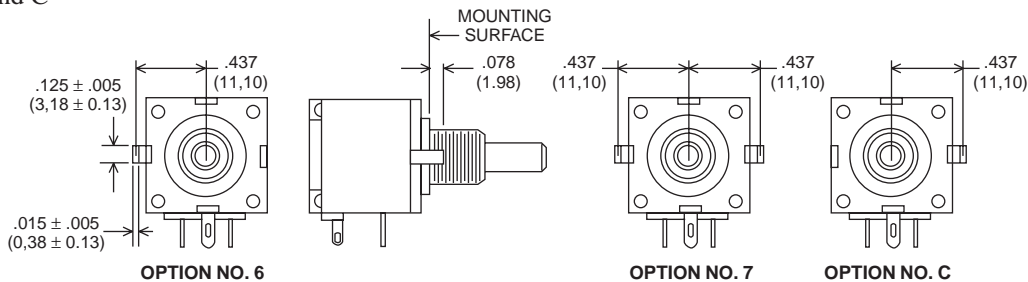

Locating Lugs Compatible With RV2

Options 8, 9 and D

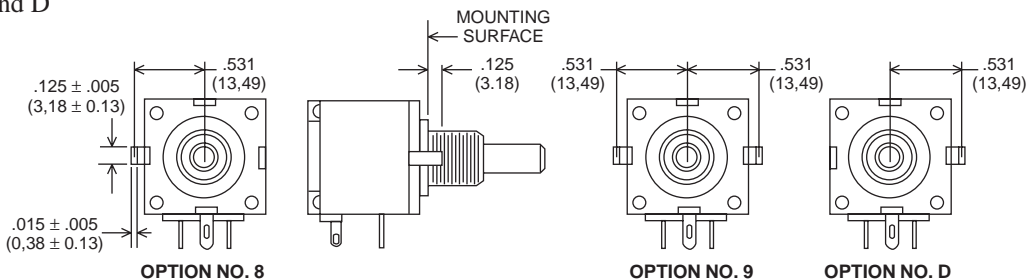

Locating Lugs Compatible With RV4

Series	Available Lug Options
70 1	1,2,3,4,5,6,7,8,9,A,B,C,D

1 Series 70 Option No. 4: No Locating Lug

Basic Dimensions in inches.
Dimensions in parentheses are in millimeters.

TOLERANCE

Dimensional Tolerance ±.016 (0,40)

Except as Specified

NOT TO SCALE

DIMENSIONS

Locating Lug Options – Series 72

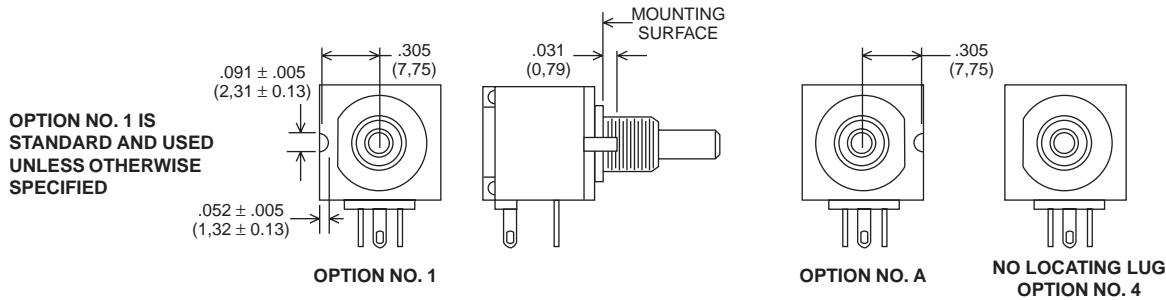

Locating Lug Options – Series 73 (Obsolete)

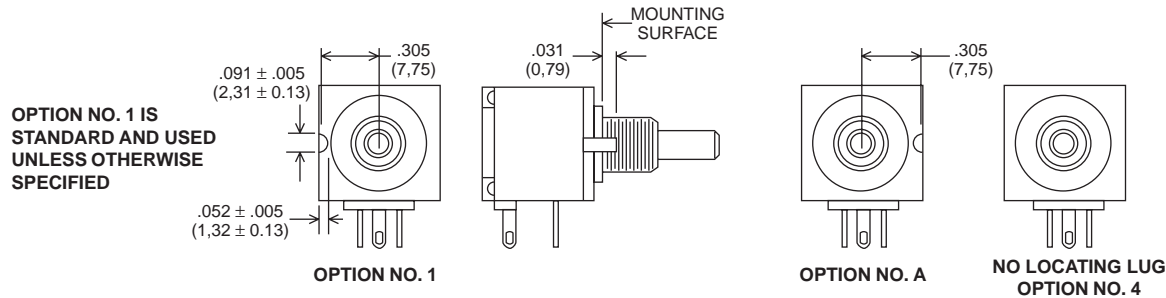

Series	Available Lug Options
72	1,4,A
73	1,4,A

Mounting Holes

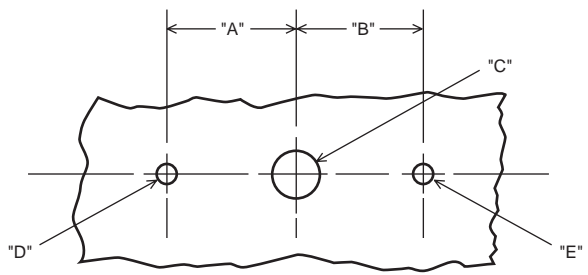

LUG OPTION	DIMENSION "A"	DIMENSION "B"	DIMENSION "C" Minimum hole dia. for 1/4" dia. bushing	DIMENSION "C" Minimum hole dia. for 3/8" dia. bushing	DIMENSION "D" Minimum hole dia.	DIMENSION "E" Minimum hole dia.
1	.305 (7,75)	*	.261 (6,63)	.406 (10,31)	.096 (2,44)	*
2	.305 (7,75)	.305 (7,75)	.261 (6,63)	.406 (10,31)	.096 (2,44)	.096 (2,44)
3	.375 (9,52)	*	.261 (6,63)	.406 (10,31)	.096 (2,44)	*
4	*	*	.261 (6,63)	.406 (10,31)	*	*
5	.375 (9,52)	.375 (9,52)	.261 (6,63)	.406 (10,31)	.096 (2,44)	.096 (2,44)
6	.437 (11,10)	*	.261 (6,63)	.406 (10,31)	.128 (3,24)	*
7	.437 (11,10)	.437 (11,10)	.261 (6,63)	.406 (10,31)	.128 (3,24)	.128 (3,24)
8	.531 (13,49)	*	.261 (6,63)	.406 (10,31)	.128 (3,24)	*
9	.531 (13,49)	.531 (13,49)	.261 (6,63)	.406 (10,31)	.128 (3,24)	*
A	*	.305 (7,75)	.261 (6,63)	.406 (10,31)	*	.096 (2,44)
B	*	.375 (9,52)	.261 (6,63)	.406 (10,31)	*	.096 (2,44)
C	*	.437 (11,10)	.261 (6,63)	.406 (10,31)	*	.128 (3,24)
D	*	.531 (13,49)	.261 (6,63)	.406 (10,31)	*	.128 (3,24)

Dimension tolerance ± .016 (0,40) except as specified
 * = Not Required

DIMENSIONS

Bushing and Locating Lug Assembly

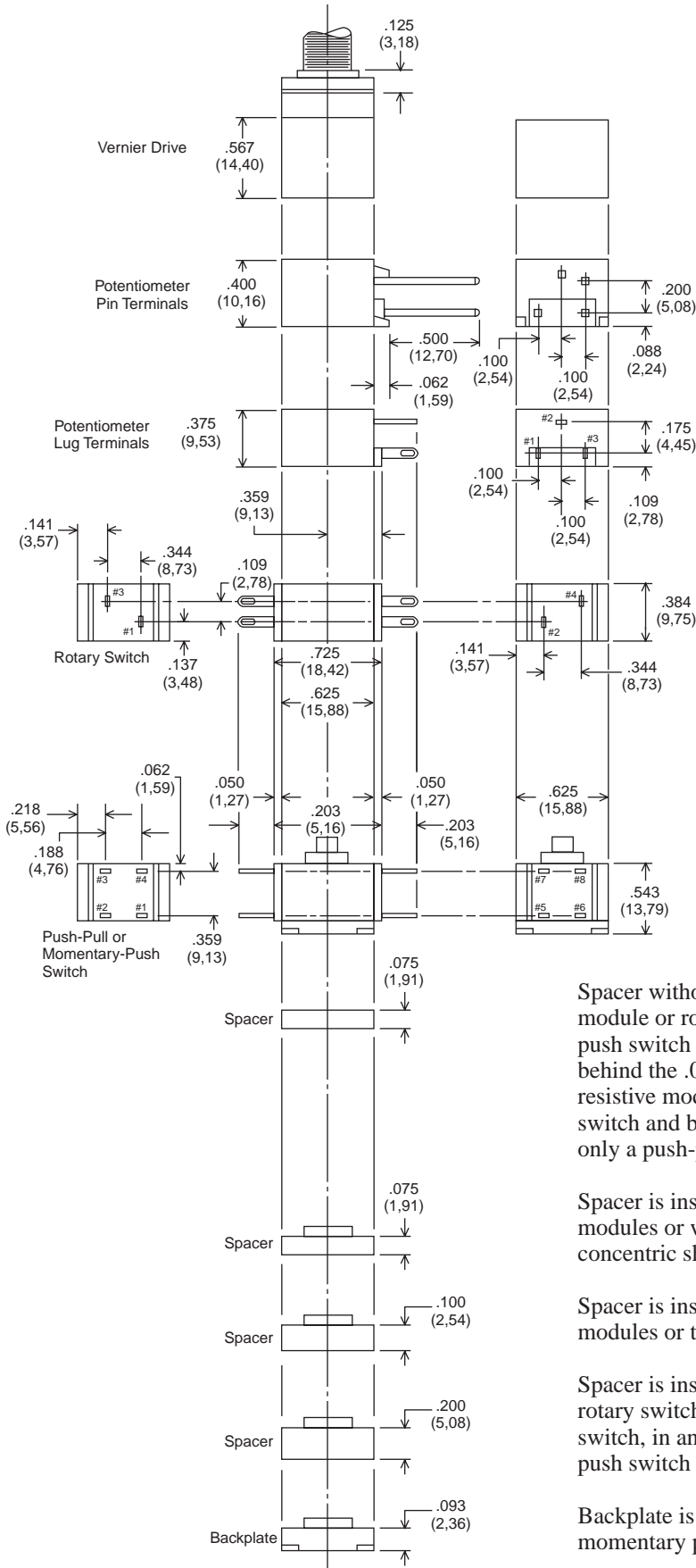

Spacer without flange is installed in front of either first resistive module or rotary switch coupled to a push-pull or momentary push switch with solid shaft construction. Also, placed either behind the .075 inch flanged spacer attached to a lug terminal resistive module with concentric shaft construction or between switch and bushing assembly with solid shaft construction when only a push-pull or momentary push switch is in the build up.

Spacer is installed between either two lug terminal resistive modules or when a rotary switch follows a rotary switch with concentric shaft construction.

Spacer is installed between either two pin terminal resistive modules or two rotary switches with concentric shaft.

Spacer is installed between a pin terminal resistive and/or a rotary switch and a pin terminal resistive module and/or a rotary switch, in any combination, coupled to a push-pull or momentary push switch with concentric shaft.

Backplate is used except when last module is a push-pull or momentary push switch.

Mod Pot

Series 70 & 72

Order Form

$\frac{5}{8}$ " Square Modular Potentiometer
Hot Molded Carbon
Conductive Plastic
Cermet

See power derating chart on page 31 for power ratings

STATE ELECTRONICS

36 ROUTE 10 EAST HANOVER, N.J. 07936
TEL. 973-887-2550 Toll Free 800-688-9711

Customer Name _____ Address _____

City, State, Zip, Country _____ Customer Part Number (When Specified) _____

STEP 1	SERIES TYPE (Circle One)	70	72																																				
STEP 2	RESISTANCE ELEMENT (Circle One)	Carbon Composition	Cermet	Conductive Plastic																																			
STEP 3	TERMINALS (Circle One)	Solder Lug	P.C. Pin																																				
STEP 4	TAPER (Insert Taper Designation Letter Below Module or Modules)	Cermet Linear Carbon Composition Linear Clockwise Modified Log Counterclockwise Modified Log Modified Linear Clockwise Exact Log Conductive Plastic Linear Clockwise Modified Log Counterclockwise Modified Log	Taper Design W U A B S dB U A B																																				
STEP 5	TOLERANCE (Insert Tolerance for each Resistance Module)	Cermet: 10% Composition: 10% Conductive Plastic: 10%																																					
STEP 6	RESISTANCE VALUE (Insert For Each Resistance Module)	Nominal Resistance Values in Ohms 50* 250 2K 10K 75K 500K 1.0 Meg. 75* 500 2.5K 20K 100K 750K 2.5 Meg.* 100 750 5K 25K 200K 5.0 Meg.* 200 1K 7.5K 50K 250K 10.0 Meg.* *Composition Only				INCHES <--> METRIC CONVERSION TABLE <table border="1"> <thead> <tr> <th>INCHES</th> <th>MM</th> <th>INCHES</th> <th>MM</th> </tr> </thead> <tbody> <tr> <td>1/8</td> <td>.123</td> <td>3/4</td> <td>.750</td> </tr> <tr> <td>1/4</td> <td>.250</td> <td>7/8</td> <td>.875</td> </tr> <tr> <td>3/16</td> <td>.312</td> <td>1</td> <td>1.000</td> </tr> <tr> <td>3/8</td> <td>.375</td> <td>1 1/8</td> <td>1.125</td> </tr> <tr> <td>7/16</td> <td>.438</td> <td>1 1/2</td> <td>1.500</td> </tr> <tr> <td>1/2</td> <td>.500</td> <td>2</td> <td>2.000</td> </tr> <tr> <td>5/8</td> <td>.625</td> <td>2 1/2</td> <td>2.500</td> </tr> </tbody> </table>		INCHES	MM	INCHES	MM	1/8	.123	3/4	.750	1/4	.250	7/8	.875	3/16	.312	1	1.000	3/8	.375	1 1/8	1.125	7/16	.438	1 1/2	1.500	1/2	.500	2	2.000	5/8	.625	2 1/2	2.500
INCHES	MM	INCHES	MM																																				
1/8	.123	3/4	.750																																				
1/4	.250	7/8	.875																																				
3/16	.312	1	1.000																																				
3/8	.375	1 1/8	1.125																																				
7/16	.438	1 1/2	1.500																																				
1/2	.500	2	2.000																																				
5/8	.625	2 1/2	2.500																																				
STEP 7	OPTIONAL MODULES (Insert Designation in Proper Module Box)	Push-Pull Switch Momentary Push Switch Rotary Action Switch Vernier Drive	Designation P M R V			* Not Available on 72																																	
STEP 8	BUSHING (Circle Length and Diameter)	Length (Dim. "A"-Inch) Plain, 1/4" Diameter (Inch) 1/4" 3/8"	Plain, 3/8" Locking, 3/8" Locking, 1/2"			* All Plastic on 72 1/4x1/4 or 3/8x3/8 only. Metal/Plastic on 73																																	
STEP 9	SHAFT* (Check Shaft Diameter Box and Circle Length) *All Plastic on 72-5 Lengths Only	Length (Dim. "B"-Inches): Maximum 2.5 Inches <input type="checkbox"/> 1/8 Inch Diameter (1/4 Inch Dia. Bushing) 5/16" 3/8" 7/16" 1/2" 5/8" 3/4" 7/8" Other <input type="checkbox"/> 1/4 Inch Diameter (3/8 Inch Dia. Bushing) 3/8" 1/2" 5/8" 3/4" 7/8" 1" 1 1/8" 1 1/8" 2" Other																																					
STEP 10	SHAFT ENDING* (Circle One)	Plain Slotted Flatted Special	Only 72's, Plain Ending on 1/8" and Slotted on 1/4" Diameter Shaft Only																																				
STEP 11	LOCATING LUG OPTIONS* (Circle One)	1* 2 3 4* 5 6 7 8 9 A* B C D	Only 3 Available on 72 and 73																																				
STEP 12	MOUNTING HARDWARE (Circle One)	Standard	Other (Specify)																																				
STEP 13	MARKING (Circle One)	Standard	Other (Specify)																																				
STEP 14	QUANTITY			Purchase Order No.																																			

REMARKS AND/OR SPECIAL FEATURES _____

ORIGINATOR'S NAME AND PHONE: _____

DATE: _____

GLOSSARY OF TERMS

Input and Output Terms

Output Voltage

(e) The voltage between the wiper terminal and the designated reference point. Unless otherwise specified, the designated reference point is the CCW terminal (See 3.1).

Figure 1

Circuit and Travel Diagram

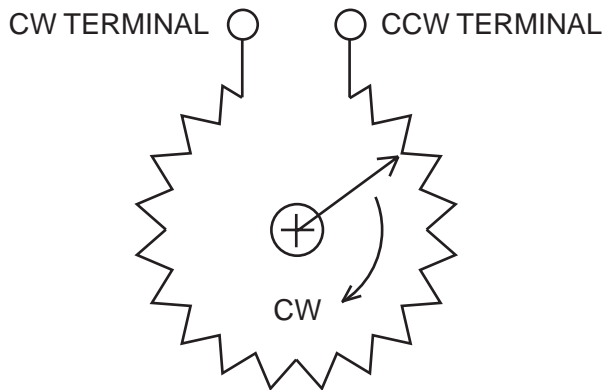

Output Ratio

(e/E) The ratio of the output voltage to the designated input reference voltage. Unless otherwise specified, the reference voltage is the total applied voltage.

Rotation and Translation

Total Mechanical Travel

The total travel of the shaft between integral stops, under the specified stop load. In potentiometers without stops, the mechanical travel is continuous.

Mechanical Overtravel-Wirewound

The shaft travel between each End Point (or Theoretical End Point for Absolute Conformity or Linearity units) and its adjacent corresponding limit of Total Mechanical Travel.

Mechanical Overtravel

The shaft travel between each Theoretical End Point and its adjacent corresponding limit of Total Mechanical Travel.

Backlash

The maximum difference in shaft position that occurs when the shaft is moved to the same actual Output Ratio point from opposite directions.

Theoretical Electrical Travel

The specified shaft travel over which the theoretical function characteristic extends between defined Output Ratio limits, as determined from the Index Point.

Electrical Overtravel-Nonwirewound

The shaft travel over which there is continuity between the wiper terminal and the resistance element beyond each end of the Theoretical Electrical Travel.

Electrical Continuity Travel

The total travel of the shaft over which electrical continuity is maintained between the wiper and the resistance element.

Tap Location

The position of a tap relative to some reference. This is commonly expressed in terms of an Output Ratio and/or a shaft position. When a shaft position is specified, the Tap Location is the center of the Effective Tap Width.

Resistance

End Resistance

The resistance measured between the wiper terminal and an end terminal with the shaft positioned at the corresponding End Point.

Temperature Coefficient Of Resistance

The unit change in resistance per degree celsius change from a reference temperature, expressed in parts per million per degree celsius as follows:

$$T.C. = \frac{R_2 - R_1}{R_1(T_2 - T_1)} \times 106$$

Where:

R1 = Resistance at reference temperature in ohms.

R2 = Resistance at test temperature in ohms

T1 = Reference temperature in degrees celsius.

T2 = Test temperature in degrees celsius.

Conformity and Linearity

Linearity

A specific type of conformity where the theoretical function characteristic is a straight line.

Mathematically:

$$\frac{e}{E} = f(W) \pm C = A(W) + B \pm C$$

Where:

A is the given slope; B is given intercept at W=0.

W = Angle or slope

Absolute Linearity

The maximum deviation of the actual function characteristic from a fully defined straight reference line. It is expressed as a percentage of the Total Applied Voltage and measured over the Theoretical Electrical Travel. An Index Point on the actual output is required.

The straight reference line may be fully defined by specifying the low and high theoretical end Output Ratios separated by the Theoretical Electrical Travel. Unless otherwise specified, these end Output Ratios are 0.0 and 1.0 respectively.

Mathematically:

$$\frac{e}{E} = A(W/W_T) + B \pm C$$

Where:

A is the given slope; B is given intercept at W=0. Unless otherwise specified: A=1; B=0

Figure 2

Absolute Linearity

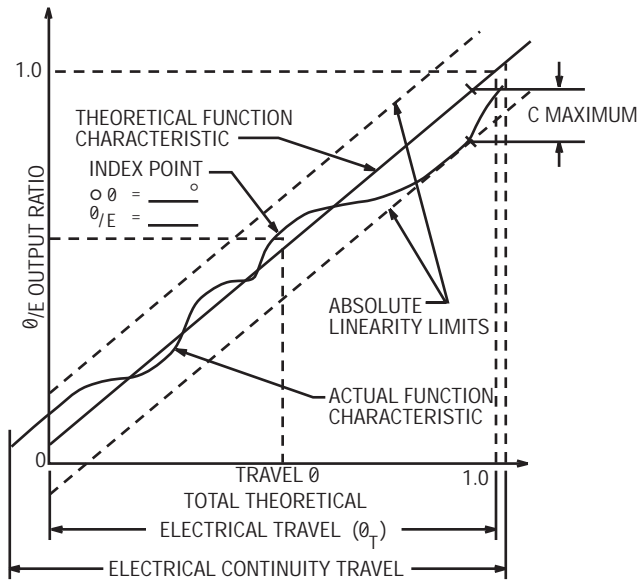

Independent Linearity

The maximum deviation, expressed as a percent of the Total Applied Voltage, of the actual function characteristic from a straight reference line with its slope and position chosen to minimize deviations over the Actual Electrical Travel, or any specified portion thereof.

Note: End Voltage requirements, when specified, will limit the slope and position of the reference line.

Mathematically:

$$\frac{e}{E} = P(W/W_A) + Q \pm C$$

Where:

P is unspecified slope; Q is unspecified intercept at W=0. And both are chosen to minimize C but are limited by the End Voltage requirements.

Figure 3

Independent Linearity

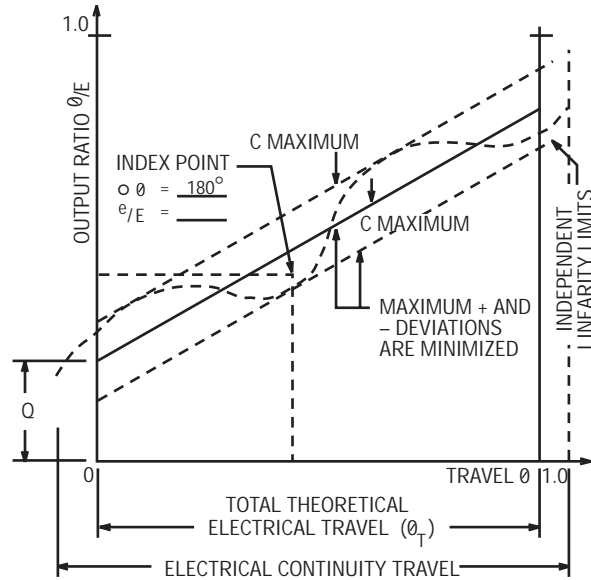

General Electrical Characteristics

Noise

Any spurious variation in the electrical output not present in the input, defined quantitatively in terms of an equivalent parasitic, transient resistance in ohms, appearing between the contact and the resistance element when the shaft is rotated or translated. The Equivalent Noise Resistance is defined independently of the resolution, the functional characteristics, and the total travel. The magnitude of the Equivalent Noise Resistance is the maximum departure from a specified reference line. The wiper of the potentiometer is required to be excited by a specified current and moved at a specified speed.

Output Smoothness (Nonwirewound Potentiometers Only)

Output Smoothness is a measurement of any spurious variation in the electrical output not present in the input. It is expressed as a percentage of the Total Applied Voltage and measured for specified travel increments over the Theoretical Electrical Travel. Output Smoothness includes effects of contact resistance variations, resolution, and other micrononlinearities in the output.

Resolution

A measure of the sensitivity to which the Output Ratio of the potentiometer may be set.

Dielectric Strength

Ability to withstand under prescribed conditions, a specified potential of a given characteristic between the terminals of each cup and the exposed conducting surfaces of the potentiometer, or between the terminals of each cup and the terminals of every other cup in the gang without exceeding a specified leakage current value.

Insulation Resistance

The resistance to a specified impressed DC voltage between the terminals of each cup and the exposed conducting surfaces of the potentiometer, or between the terminals of each cup and the terminals of every other cup in the gang, under prescribed conditions.

Power Rating

The maximum power that a potentiometer can dissipate under specified conditions while meeting specified performance requirements.

Power Derating

The modification of the nominal power rating for various considerations such as Load Resistance, Output Slopes, Ganging, nonstandard environmental conditions and other factors.

Life

The number of shaft revolutions or translations obtainable under specific operating conditions and within specified allowable degradations of specific characteristics.

Mechanical Characteristics

Shaft Runout

The eccentricity of the shaft diameter with respect to the rotational axis of the shaft, measured at a specified distance from the end of the shaft. The body of the potentiometer is held fixed and the shaft is rotated with a specified load applied radially to the shaft. The eccentricity is expressed in inches, TIR.

Lateral Runout

The perpendicularity of the mounting surface with respect to the rotational axis of the shaft, measured on the mounting surface at a specified distance from the outside edge of the mounting surface. The shaft is held fixed and the body of the potentiometer is rotated with specified loads applied radially and axially to the body of the pot. The Lateral Runout is expressed in inches.

Shaft Radial Play

The total radial excursion of the shaft, measured at a specified distance from the front surface of the unit. A specified radial load is applied alternately in opposite directions at a specified point. Shaft Radial Play is expressed in inches.

Shaft End Play

The total axial excursion of the shaft, measured at the end of the shaft with a specified axial load supplied alternately in opposite directions. Shaft End Play is expressed in inches.

Starting Torque

The maximum moment in the clockwise and counterclockwise directions required to initiate shaft rotation anywhere in the Total Mechanical Travel.

Running Torque

The maximum moment in the clockwise and counterclockwise directions required to sustain uniform shaft rotation at a specified speed throughout the Total Mechanical Travel.

Moment of Inertia

The mass moment of inertia of the rotating elements of the potentiometer about their rotational axis.

Stop Strength

Static Stop Strength

The maximum static load that can be applied to the shaft at each mechanical stop for a specified period of time without permanent change of the stop positions greater than specified.

Dynamic Stop Strength

The inertia load, at a specified shaft velocity and a specified number of impacts, that can be applied to the shaft at each stop without a permanent change of the stop position greater than specified.

General Terms and Conditions of Sale

Orders

All orders are subject to acceptance by **State Electronics**, E. Hanover, NJ. No order or contract shall be deemed accepted unless and until such acceptance is made in writing by **State Electronics**.

All agreements are more contingent upon strikes, accidents or causes of delay beyond our control

Prices and Specifications

Prices, quotations, specifications and other terms and all statements appearing in the Company's catalogs and advertisements, and otherwise made by the Company, are subject to change without notice. **State Electronics** reserves the right to make changes in design at any time without incurring any obligation to provide same units previously purchased or to continue to supply discontinued items. The specifications shown in the sales literature are not always the latest version. Certified current specification prints are available upon request.

Unless specifically provided in writing, prices quoted are based upon manufacture of quantities and types originally specified and are subject to revision when interpretation or engineering changes are initiated by the customer. Quoted prices are based upon present cost of materials and labor and are subject to change without notice.

We are not responsible for typographical errors made in any of our publications or for stenographic or clerical errors made in preparations of quotations, all such errors are subject to correction.

Delivery

Delivery promise is based on our best estimate of the date material will be shipped from our factory and we assume no responsibility for losses, damage or consequential damages due to delays.

Terms of Payment

On approved orders, terms are net thirty (30) days from the date of invoice. The Company may at any time, when in its opinion the financial condition of the customer warrants it, either hold or suspend credit. In cases where credit is not established or satisfactory financial information is not available, the terms are cash with order or C.O.D. at the option of the Company. Each shipment will be considered a separate and independent transaction and payment should be made accordingly.

Shipments

All shipments are made F.O.B. shipping point (unless otherwise specified) and packaging for domestic shipment is included in the quoted price. When special domestic or export packaging is specified involving greater expense than is customary, a charge will be made to cover such extra expense. Unless otherwise specified, we will normally use the best, least expensive surface transportation. Reasonable care is exercised in packaging our products for shipment and no responsibility is assumed by the Company for delay, breakage or damage after having made delivery in good order to the carrier. All claims for breakage or damage should be made to the carrier, but will be glad to render all possible assistance in securing satisfactory adjustment of such claims.

Claims and Rejected Material

No products may be returned without a return authorization (RMA).

STATE
ELECTRONICS

36 Route 10
East Hanover, NJ 07936
Phone 973-887-2550
Toll Free 1-800-688-9711
FAX 973-887-1940
<http://www.potentiometers.com>

© 1998-2006