

EV-T2SC-EM - Protective cover



1627635

<https://www.phoenixcontact.com/us/products/1627635>

Please be informed that the data shown in this PDF document is generated from our online catalog. Please find the complete data in the user documentation. Our general terms of use for downloads are valid.



CHARX connect basic, Protective cover, square, Accessories, with self-locking mechanism, for attaching to infrastructure charging sockets, Type 2, IEC 62196-2, Front mounting, housing: black, Embossed PHOENIX CONTACT logo

Product description

Self-closing protective cover for infrastructure charging socket

Your advantages

- Developed and produced in accordance with the IATF 16949 automotive standard and ISO 9001
- Individual branding, thanks to the use your own logo
- Reliable protection of your socket outlet from weather and vandalism
- Extremely easy assembly, thanks to a front-side screw connection
- Reduced assembly work, thanks to the pre-injected seal
- No separate panel mounting frame required

Commercial data

Item number	1627635
Packing unit	1 pc
Minimum order quantity	1 pc
Sales key	EM01
Product key	XWBAFC
Catalog page	Page 46 (C-7-2019)
GTIN	4055626346083
Weight per piece (including packing)	108.1 g
Weight per piece (excluding packing)	105 g
Customs tariff number	39269097
Country of origin	PL

EV-T2SC-EM - Protective cover



1627635

<https://www.phoenixcontact.com/us/products/1627635>

Technical data

Product properties

Product type	Protective cover for Socket Outlet
Product family	CHARX connect basic
Application	for attaching to infrastructure charging sockets
Design (Protective cover)	square
Type	Accessories
Design	with self-locking mechanism
Affixed logo	Embossed PHOENIX CONTACT logo
Charging standard	Type 2
Charging mode	Mode 3, Case B

Dimensions

Width	85 mm
Height	93.7 mm
Depth	32.5 mm
Width	60 mm
Height	60 mm

Material specifications

Color (Housing)	black (9005)
Material (Housing)	Plastic

Environmental and real-life conditions

Ambient conditions

Degree of protection (Protective cover)	IP54
	IK08
Ambient temperature (operation)	-30 °C ... 50 °C
Ambient temperature (storage/transport)	-40 °C ... 80 °C

Standards and regulations

Standards

Standards/regulations	IEC 62196-2
-----------------------	-------------

Mounting

Mounting type Protective cover	Front mounting (front screw connection)
Thread type	()
Screws included in the scope of delivery	M4 cylinder head screws Torx-Plus 10IPR

EV-T2SC-EM - Protective cover

1627635

<https://www.phoenixcontact.com/us/products/1627635>



Drawings

Dimensional drawing

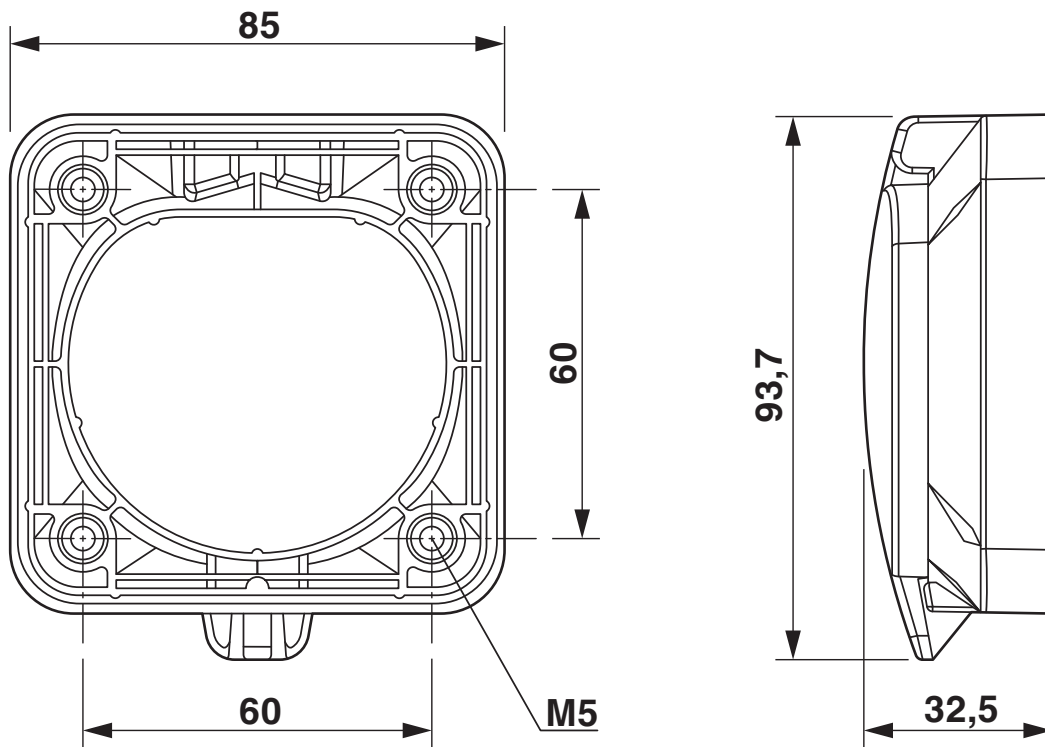

Dimensional drawing

EV-T2SC-EM - Protective cover

1627635

<https://www.phoenixcontact.com/us/products/1627635>



Dimensional drawing

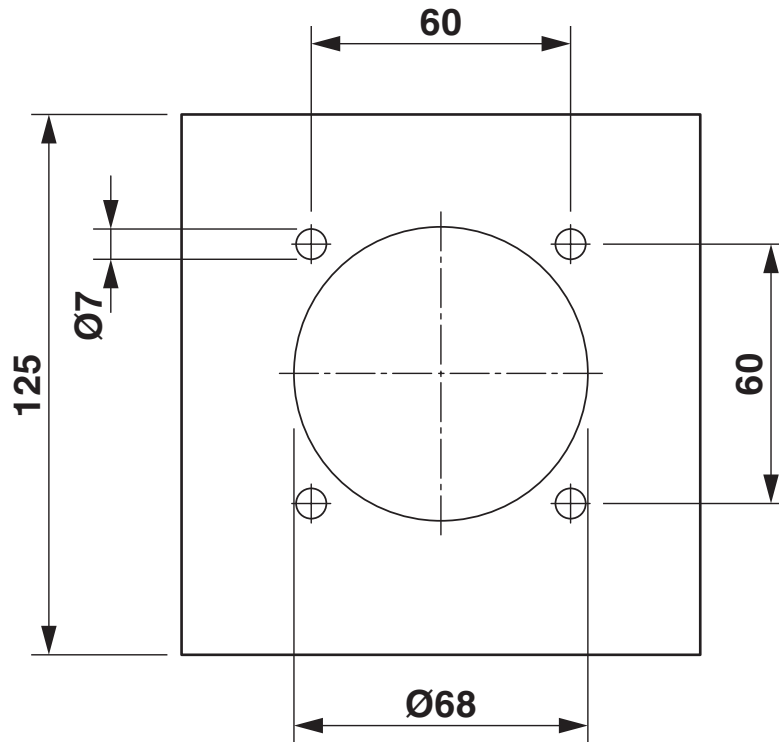

Hole image

EV-T2SC-EM - Protective cover

1627635

<https://www.phoenixcontact.com/us/products/1627635>

Schematic diagram

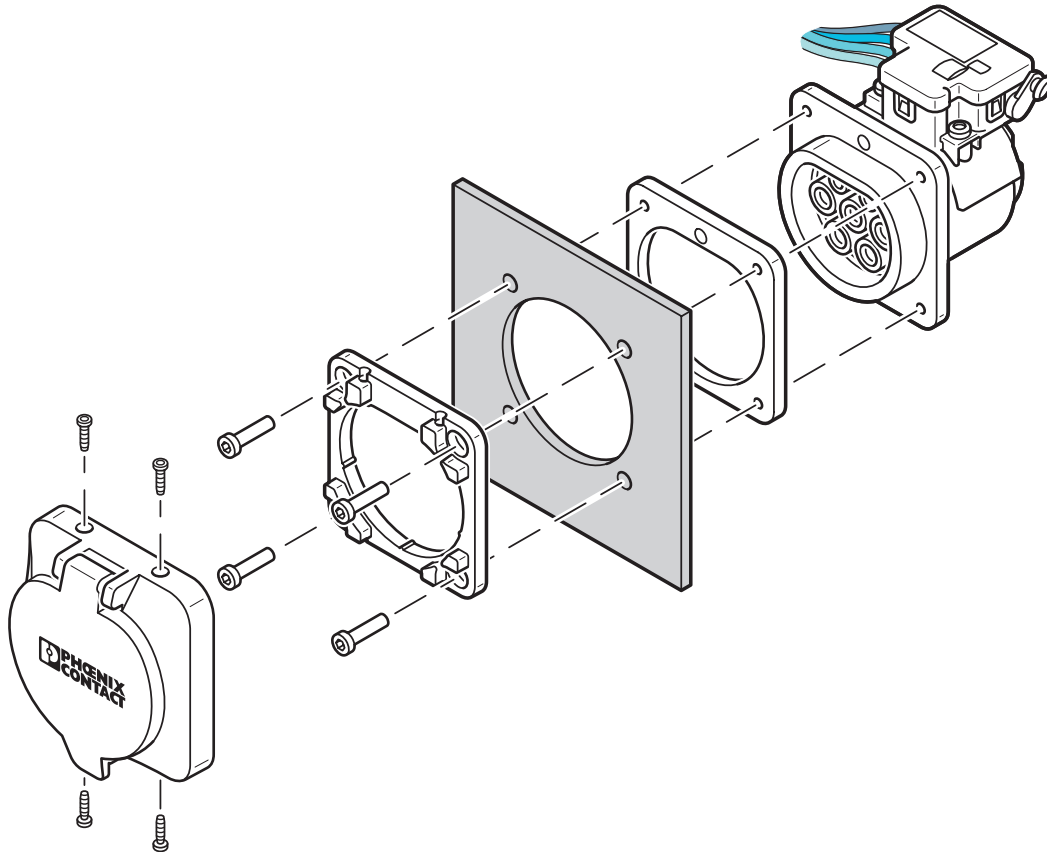

Rear mounting with front protective cover screw connection

The screw connection for a protective cover (EV-T2SC-EM) from the accessories range only supports front mounting with a corresponding fixing frame (EV-T2SF-EM). The panel thickness must not exceed 5 mm. The sealing frame that is slid on from the rear must contact the housing panel flush with the flat side and must completely surround the infrastructure socket outlet.

EV-T2SC-EM - Protective cover



1627635

<https://www.phoenixcontact.com/us/products/1627635>

Classifications

ECLASS

ECLASS-11.0	27144792
ECLASS-12.0	27144792
ECLASS-13.0	27144792

ETIM

ETIM 9.0	EC002884
----------	----------

UNSPSC

UNSPSC 21.0	39121500
-------------	----------

EV-T2SC-EM - Protective cover



1627635

<https://www.phoenixcontact.com/us/products/1627635>

Environmental product compliance

EU RoHS

Fulfills EU RoHS substance requirements	Not applicable, No electrical and electronic equipment (EEE), cannot be used in EEE
---	---

EU REACH SVHC

REACH candidate substance (CAS No.)	No substance above 0.1 wt%
-------------------------------------	----------------------------

EV-T2SC-EM - Protective cover

1627635

<https://www.phoenixcontact.com/us/products/1627635>



Accessories

EV-T2SF-EM - Fixing frame

1627637

<https://www.phoenixcontact.com/us/products/1627637>

CHARX connect basic, Fixing frame, Accessories, for attaching to infrastructure charging sockets, Type 2, IEC 62196-2, Front mounting, housing: black, Without logo



Phoenix Contact 2024 © - all rights reserved
<https://www.phoenixcontact.com>

Phoenix Contact USA
586 Fulling Mill Road
Middletown, PA 17057, United States
(+717) 944-1300
info@phoenixcon.com