



AVX
EMI Filters

HIGH-REL EMI FILTERS

Noise is the enemy of good engineering design. Properly installed EMI filters suppress such electromagnetic interference on power and signal lines, while allowing desired signals to pass. For critical EMI filter applications, high reliability is of the utmost importance.

High reliability applications have diverse requirements, ranging from a need for a long operating life in medical or military systems to avoiding the prohibitive cost of replacing a faulty component in a satellite, undersea cable, or other inaccessible system. High-rel filters satisfy application-critical requirements in many environments:

- Space/Satellite Systems
- Military Aircraft
- Guidance Systems
- Command, Control & Communications (C³)
- Missile Systems
- Weapon Systems
- Radar Systems
- Electro Optical Systems
- Electronic Countermeasures
- Electronic Warfare
- Pacemakers
- Medication Monitors

HIGH-REL STANDARDS

Reliability must be designed into an EMI filter. Every step in its manufacture from material selection through testing and characterization must be considered. To assure conformance to clearly-defined product and performance parameters, specifications have evolved for electrical performance, mechanical configurations, test methods, screening and qualification procedures.

AVX Filters delivers high quality EMI filters which meet applicable portions of these high-reliability standards:

- MIL-F-15733
- MIL-F-28861
- MIL-STD-202
- MIL-STD-790
- MIL-C-123
- MIL-STD-220
- MIL-Q-9858
- MIL-I-45208A
- ISO 9000
- EIA-RS-469

AVX FILTERS AT THE LEADING EDGE

AVX Filters Corporation continues to provide innovative solutions to the high performance needs of its customers. It has pioneered many breakthroughs which have advanced the state-of-the-art in this demanding discipline, including:

- The first to qualify to the new High-Reliability Filter Spec, MIL-F-28861.

- Facility qualified to MIL-STD-790 during first round of audits for filter manufacturers.
- The first solder-in filter line to offer 400°C installation temperature.
- The first filter line designed to meet the new MIL-Spec requirements for heat rise/reactive current in 125 VAC and 230 VAC 400 Hz applications.
- The first to offer a filter line of hermetically sealed bolt style filters.

CUSTOM AND SEMI-CUSTOM

In addition to standard catalog and QPL EMI filters, AVX Filters produces two classes of these special products: Semi-custom and Custom. Semi-custom involves variations in electrical parameters, testing, and limited mechanical changes from standard product designs. Delivery is slightly longer and price is slightly higher than standard products.

Custom products require longer lead time for design and manufacturing, but give designers freedom to specify non-standard mechanical and electrical filter designs.

AVX Filters dedicates a unique internal part number to every semi-custom and custom component. This insures continued configuration control for each part, allows future changes to be easily implemented, and provides assurance that the design always matches the customer requirements.

ENGINEER TO ENGINEER

Our application engineering staff will assist in defining your filter requirements, while recommending advantages, reliability, quality assurance levels, and filter performance at the lowest practical cost. They will help in filter selection and specification, including meeting DESC requirements. SCD models are available to assist you in the design process. A custom filter part number will be assigned exclusively to your SCD. To obtain prompt, professional assistance, call (818) 767-6770.

QUALITY ASSURANCE

Quality assurance is built into every stage of manufacturing and testing. AVX Filters controls the entire process, from the capacitor's dielectric formulation through final filter test. This results in absolute traceability by lot number to a specific dielectric batch, as well as the subsequent materials, equipment and employees involved in the tightly-controlled manufacturing and testing process. In addition, critical processes are monitored using SQC, SPC techniques.

ISO 9001
CERTIFIED

Contents

- Filter Product Selector** 2

- Solder-In Style** 3-16

- Advanced Technology Filters** 17-18
Miniature, Subminiature & Microminiature

- Bolt Style** 19-26

- Advanced Technology Filters** 27-28
Miniature, Subminiature & Microminiature

- Cylindrical Style** 29-45

- Advanced Technology Filters** 46-47
Miniature, Subminiature & Microminiature

- Advanced Technology Filters** 48
Hermetic High Temperature Solder-Ins

- Filter Plates** 49-50

- Filter Design Guide** 51
High Reliability – M28861 Screening & R-Level Screening

- Screw & Locking Washer Table** 52

- Filter Types** 53

- Filter Design Guide** 54
High Reliability – Installation, Handling, Hardware Options

- Military Qualified Products** 55

- How To Order** 56-58

SOLDER-IN HIGH TEMP EMI FILERS



FEATURES

- Hermetically sealed on one end
- C & L Circuit Configurations
- Filter Frequency Range: 10MHz to 26GHz
- Up to 300C Installation Temperature
- Available in Miniature Sizes (see page 17-18)

BOLT STYLE EMI FILERS



FEATURES

- Filter Frequency Range: 1MHz to 10GHz
- Available in Miniature Sizes (see page 27-28)

CYLINDRICAL STYLE EMI FILERS



FEATURES

- High Capacitance Values Available
- Low Profile
- Filter Frequency Range: 500KHz to 10GHz
- Available in Miniature Sizes (see page 46-47)

HERMETICALLY SEALED CYLINDRICAL EMI FILERS



FEATURES

- Hermetically Sealed on Both Ends
- Most Space Available in 0.375/0.410 inch Diameter
- Circuit Options:
- MIL-F-28861/2, 3, 4, 5 QPL Equivalent
- Filter Frequency Range: 30KHz to 10GHz

CUSTOM FILTER ASSEMBLIES AND PARTS

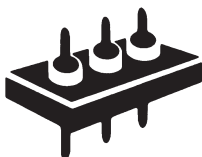

FEATURES

- Custom Designed to Customer Requirements
- Up to 300C Installation Temperature
- 100% Tested and Burning Prior to Shipment
- May be supplied with MIL-F-28861/12, 14, 15 filters installed as available (see QPL listings)
- Can be supplied with filters approved to DESC drawings 88010, 84080, 84081, 84082 or to AVX filters catalog equivalents design to the requirements MIL-F-28861.

Solder-In Style High Temp EMI Filters

ZZ Series – .118 Dia. – Circuits Available - C

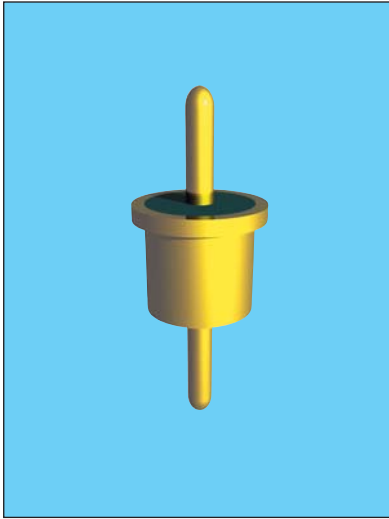

APPLICATIONS

The ZZ series is intended for use as a high reliability alternative to a commonly available commercial filter type. Due to its smaller body diameter, capacitance is limited. It does provide effective filtering in the MICROWAVE frequency spectrum from 100 MHz through 26 GHz. Designed to be soldered into a package, bracket or bulkhead (and maintain hermeticity),

it is ideal for high impedance circuits where large capacitance values are not practical.

Alternate lead lengths or special capacitance values are available upon request.

Custom packages or bracket assemblies utilizing this feedthru can be furnished to your specifications.

CHARACTERISTICS

- High temperature construction with-stands 300°C installation temperatures.
- Features rugged monolithic discoidal capacitor construction.
- Glass hermetic seal on one end with epoxy seal on the opposite end.
- High purity gold plating provides excellent solderability or compatibility with thermal and ultrasonic wire bonding.

SPECIFICATIONS

1. Finish: Gold standard –
Silver and solder coat available
2. Material:
Case: Cold rolled steel
Leads: Alloy 52 steel
3. Operating Temperature Range:
-55°C to +125°C
4. Insulation Resistance:
At 25°C: 1,000 megohm-microfarad min., or 100,000 megohms min., whichever is less
At 125°C: 100 megohm-microfarad min., or 10,000 megohms min., whichever is less
5. Dielectric Withstanding Voltage (DWW):
R-level designs:
2.0 times rated DC voltage
Class B, Class S designs:
2.5 times rated DC voltage
6. DC Resistance (DCR): .01 ohm, maximum
7. Dissipation Factor (DF): 3% maximum
8. Rated DC Current: 5 Amps, maximum
9. Maximum Installation Temperature:
300°C
10. Supplied with 60/40 solder preform for easy installation

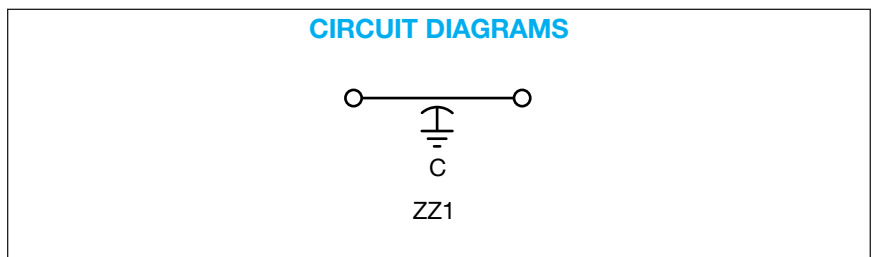
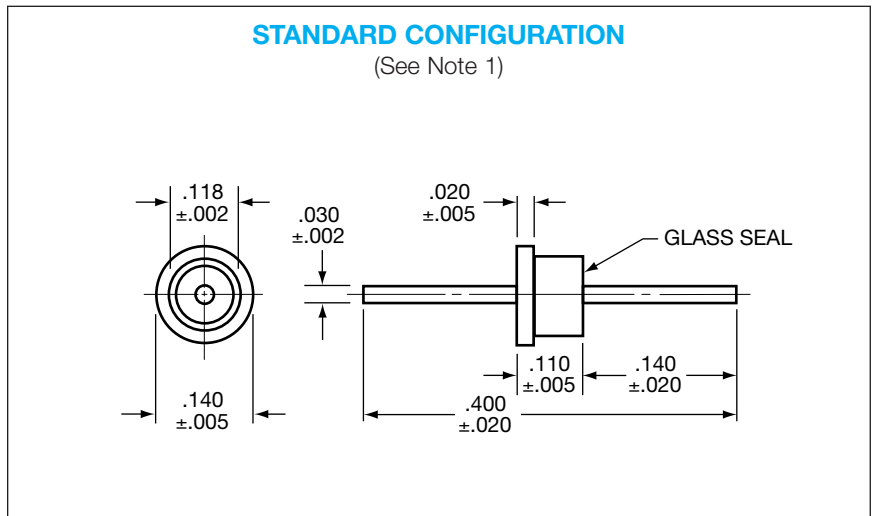

millimeters (inches)

0.05 (.002)	3.05 (.120)
0.13 (.005)	3.43 (.135)
0.51 (.020)	3.56 (.140)
1.02 (.040)	3.68 (.145)
2.79 (.110)	10.16 (.400)
2.95 (.116)	— —

(See Note 2)

Notes:

1. Glass seal on end opposite flange.
2. Metric equivalent dimensions given for information only.

Solder-In Style High Temp EMI Filters

ZZ Series – .118 Dia. – Circuits Available – C

SPECIFICATIONS

AVX P/N	Current (A)	CKT	DC Voltage	CAP Min. (pF)	Insertion Loss ¹ Per MIL-STD-220, +25°C				
					1 MHz	10 MHz	100 MHz	1000 MHz	10 GHz
ZZ1C3-250H	5	C	50	25	–	–	–	10	15
ZZ1C3-500H	5	C	50	50	–	–	1	15	25
ZZ1C3-101H	5	C	50	100	–	–	3	20	30
ZZ1C3-102H	5	C	50	1000	–	4	20	31	55
ZZ1C3-152H	5	C	50	1500	–	5	21	42	55
ZZ1A3-250H	5	C	100	25	–	–	–	10	15
ZZ1A3-500H	5	C	100	50	–	–	1	15	25
ZZ1A3-101H	5	C	100	100	–	–	3	20	30
ZZ1A3-102H	5	C	100	1000	–	4	18	36	55
ZZ1A3-152H	5	C	100	1500	–	5	21	42	55
ZZ1B3-250H	5	C	200	25	–	–	–	10	15
ZZ1B3-500H	5	C	200	50	–	–	1	15	25
ZZ1B3-101H	5	C	200	100	–	–	3	20	30
ZZ1B3-102H	5	C	200	1000	–	4	18	36	55

¹ Insertion loss limits are based on theoretical values.
Actual measurements may vary due to internal capacitor resonances and other design constraints.

For special multi-unit assemblies see Multi-Component Filter Brackets section.

Solder-In Style High Temp EMI Filters

ZS/ZR Series – .128 Dia. – Circuits Available – C & L

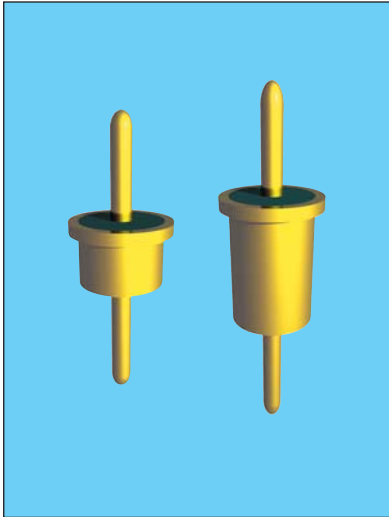

APPLICATIONS

The ZS series provides effective filtering in the MICROWAVE frequency spectrum from 10 MHz through 26 GHz. Designed to be soldered into a package, bracket or bulkhead (and maintain hermeticity), it is ideal for high impedance circuits where large capacitance values are not practical. In the "L" section version an internal ferrite bead element provides both induc-

tance and series resistance (lossy characteristic) which improves insertion loss and provides superior transient performance.

Alternate lead lengths or special capacitance values may be ordered.

Custom packages or bracket assemblies utilizing this feedthru can be furnished to your specifications.

CHARACTERISTICS

- Meets or exceeds the applicable portions of MIL-F-28861/12. See QPL listings.
- High temperature construction withstands 300°C installation temperatures.
- Features rugged monolithic discoidal capacitor construction.
- Glass hermetic seal on one end with epoxy seal on the opposite end.
- High purity gold plating provides excellent solderability or compatibility with thermal and ultrasonic wire bonding.

SPECIFICATIONS

1. Plating: Gold standard –
Silver and solder coat available
2. Material:
Case: Cold rolled steel
Leads: Alloy 52 steel
3. Operating Temperature Range:
-55°C to +125°C
4. Insulation Resistance:
At 25°C: 1,000 megohm-microfarad min., or 100,000 megohms min., whichever is less
At 125°C: 100 megohm-microfarad min., or 10,000 megohms min., whichever is less
5. Dielectric Withstanding Voltage (DWW):
R-level designs:
2.0 times rated DC voltage
Class B, Class S designs:
2.5 times rated DC voltage
6. DC Resistance (DCR): .01 ohm, maximum
7. Dissipation Factor (DF): 3% maximum
8. Rated DC Current: 5 Amps, maximum
9. Maximum Installation Temperature: 300°C
10. Supplied with 60/40 solder preform for easy installation
11. Insertion Loss for the "C" and "L" circuits are equivalent due to the saturation characteristic of the ferrite bead element at full rated current. At lower currents the "L" becomes much more effective.

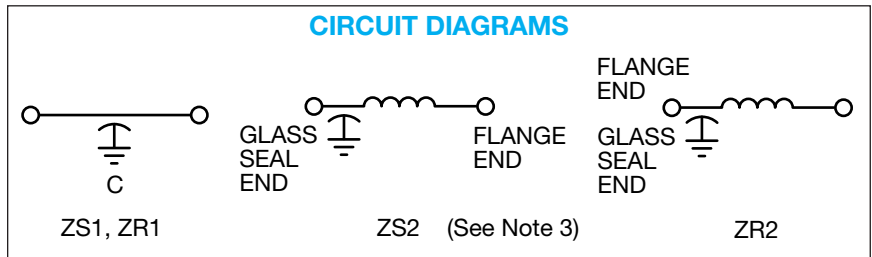
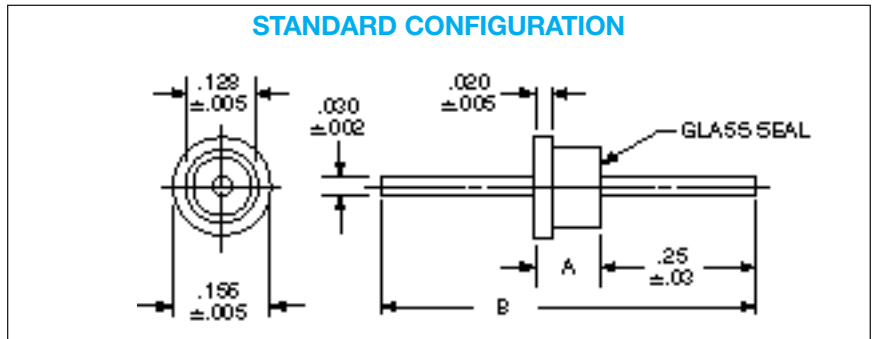

millimeters (inches)

0.05 (.002)	3.25 (.128)
0.13 (.005)	3.96 (.156)
0.51 (.020)	5.08 (.200)
0.76 (.030)	6.4 (.25)
0.8 (.03)	15.88 (.625)
2.79 (.110)	18.16 (.715)

(See Note 4)

Circuit Diagram	Dimensions	
	A ±.005	B Nom.
L	.200	.715
C	.110	.625

Notes:

1. Outline drawing shows standard ZS configuration. Also available with glass seal at the opposite end, ZR reverse configuration.
2. MIL-F-28861/12 style FS70 equivalent to standard ZS configuration. Style FS71 is reverse ZR configuration.
3. For ZS2 or ZR2 L-Section Filters inductor always positioned at epoxy-filled end.
4. Metric equivalent dimensions given for information only.

MIL-F-28861/12 (See Note 2)

Dash No.	Style
001 through 016, 033 and 034	FS70
017 through 032, 035 and 036	FS71

Solder-In Style High Temp EMI Filters

ZS/ZR Series – .128 Dia. – Circuits Available – C & L

SPECIFICATIONS

AVX P/N	Current (A)	CKT	DC Voltage	CAP Min.	Insertion Loss ¹ Per MIL-STD-220, +25°C					
					500 KHz	1 MHz	10 MHz	100 MHz	1000 MHz	10 GHz
ZS1C2-501H	5	C	50	500 pF	–	–	–	15	30	50
ZS1C2-102H	5	C	50	1000 pF	–	–	4	20	31	55
ZS1C2-122H	5	C	50	1200 pF	–	–	5	20	35	55
ZS1C2-272H	5	C	50	2700 pF	–	–	10	25	40	60
ZS1C2-502H	5	C	50	5000 pF	–	–	15	30	45	60
ZS1C2-103H	5	C	50	0.010 µF	–	4	20	35	48	60
ZS1C2-153H	5	C	50	0.015 µF	–	7	25	40	50	60
ZS2C2-501H	5	L	50	500 pF	–	–	–	15	30	50
ZS2C2-102H	5	L	50	1000 pF	–	–	4	20	33	55
ZS2C2-122H	5	L	50	1200 pF	–	–	5	20	37	55
ZS2C2-272H	5	L	50	2700 pF	–	–	10	25	40	60
ZS2C2-502H	5	L	50	5000 pF	–	–	15	30	45	60
ZS2C2-103H	5	L	50	0.010 µF	–	4	20	38	50	60
ZS2C2-153H	5	L	50	0.015 µF	–	7	25	42	50	60
ZS1A2-101H	5	C	100	100 pF	–	–	–	3	20	30
ZS1A2-501H	5	C	100	500 pF	–	–	–	15	30	50
ZS1A2-102H	5	C	100	1000 pF	–	–	4	20	31	55
ZS1A2-122H	5	C	100	1200 pF	–	–	5	20	35	55
ZS1A2-272H	5	C	100	2700 pF	–	–	10	25	40	60
ZS1A2-502H	5	C	100	5000 pF	–	–	15	30	45	60
ZS1A2-103H	5	C	100	0.010 µF	–	4	20	35	48	60
ZS1A2-153H	5	C	100	0.015 µF	–	7	25	40	50	60
ZS2A2-100H	5	L	100	10 pF	–	–	–	–	5	10
ZS2A2-250H	5	L	100	25 pF	–	–	–	–	10	15
ZS2A2-101H	5	L	100	100 pF	–	–	–	3	20	30
ZS2A2-501H	5	L	100	500 pF	–	–	–	15	30	50
ZS2A2-102H	5	L	100	1000 pF	–	–	4	20	33	55
ZS2A2-122H	5	L	100	1200 pF	–	–	5	20	37	55
ZS2A2-272H	5	L	100	2700 pF	–	–	10	25	40	60
ZS2A2-502H	5	L	100	5000 pF	–	–	15	30	45	60
ZS2A2-103H	5	L	100	0.010 µF	–	4	20	38	50	60
ZS2A2-153H	5	L	100	0.015 µF	–	7	25	42	50	60

continued

¹ Insertion loss limits are based on theoretical values. Actual measurements may vary due to internal capacitor resonances and other design constraints.

NOTE: AVX Filters' Standard configurations (e.g. ZS, YS, XS, WS) have the hermetic glass seal opposite the flange end. All parts are capable of the reverse configuration with the glass seal at the flange end. All parameters are otherwise identical. The part number changes from "S" to "R" (e.g., standard = ZS1C2-153H; reverse = ZR1C2-153H).

For special multi-unit assemblies see Multi-Component Filter Brackets section.

Solder-In Style High Temp EMI Filters

ZS/ZR Series – .128 Dia. – Circuits Available – C & L

SPECIFICATIONS

AVX P/N	Current (A)	CKT	DC Voltage	CAP Min.	Insertion Loss ¹ Per MIL-STD-220, +25°C					
					500 KHz	1 MHz	10 MHz	100 MHz	1000 MHz	10 GHz
ZS1B2-100H	5	C	200	10 pF	–	–	–	–	4	10
ZS1B2-250H	5	C	200	25 pF	–	–	–	–	10	15
ZS1B2-101H	5	C	200	100 pF	–	–	–	3	20	30
ZS1B2-501H	5	C	200	500 pF	–	–	–	15	30	50
ZS1B2-102H	5	C	200	1000 pF	–	–	4	20	31	55
ZS1B2-122H	5	C	200	1200 pF	–	–	5	20	35	55
ZS1B2-272H	5	C	200	2700 pF	–	–	10	25	40	60
ZS2B2-100H	5	L	200	10 pF	–	–	–	–	5	10
ZS2B2-250H	5	L	200	25 pF	–	–	–	–	10	15
ZS2B2-101H	5	L	200	100 pF	–	–	–	3	20	30
ZS2B2-501H	5	L	200	500 pF	–	–	–	15	30	50
ZS2B2-102H	5	L	200	1000 pF	–	–	4	20	33	55
ZS2B2-122H	5	L	200	1200 pF	–	–	5	20	37	55
ZS2B2-272H	5	L	200	2700 pF	–	–	10	25	40	60

¹ Insertion loss limits are based on theoretical values.

Actual measurements may vary due to internal capacitor resonances and other design constraints.

NOTE: AVX Filters' Standard configurations (e.g. ZS, YS, XS, WS) have the hermetic glass seal opposite the flange end. All parts are capable of the reverse configuration with the glass seal at the flange end. All parameters are otherwise identical. The part number changes from "S" to "R" (e.g., standard = ZS1C2-153H; reverse = ZR1C2-153H).

For special multi-unit assemblies see **Multi-Component Filter Brackets** section.

Solder-In Style High Temp EMI Filters

YS/YR Series – .165 Dia. – Circuits Available – C & L

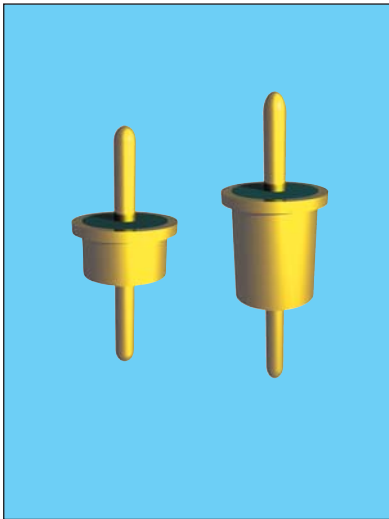

APPLICATIONS

The YS series provides increased filtering in the MICROWAVE frequency spectrum from 1 MHz through 10 GHz. Previously unavailable in the industry as a solder-in device, this unique design offers higher values of capacitance than were previously available. Designed to be soldered into a package, bracket or bulkhead (and maintain hermeticity), it is ideal for high impedance circuits where large capacitance values are not practical. In the “L”

section version an internal ferrite bead element provides both inductance and series resistance (lossy characteristic) which improves insertion loss and provides superior transient performance.

Alternate lead lengths or special capacitance values may be ordered.

Custom packages or bracket assemblies utilizing this feedthru can be furnished to your specifications.

CHARACTERISTICS

- Meets or exceeds the applicable portions of MIL-F-28861/15. See QPL listings.
- High temperature construction withstands 300°C installation temperatures.
- Features rugged monolithic discoidal capacitor construction.
- Glass hermetic seal on one end with epoxy seal on the opposite end.
- High purity gold plating provides excellent solderability or compatibility with thermal and ultrasonic wire bonding.

SPECIFICATIONS

1. Plating: Gold standard – Silver available
2. Material:
Case: Cold rolled steel
Leads: Alloy 52 steel
3. Operating Temperature Range:
-55°C to +125°C
4. Insulation Resistance:
At 25°C: 1,000 megohm-microfarad min., or 100,000 megohms min., whichever is less
At 125°C: 100 megohm-microfarad min., or 10,000 megohms min., whichever is less
5. Dielectric Withstanding Voltage (DWW):
R-level designs:
2.0 times rated DC voltage
Class B, Class S designs:
2.5 times rated DC voltage
6. DC Resistance (DCR): .01 ohm, maximum
7. Dissipation Factor (DF): 3% maximum
8. Rated DC Current: 5 Amps, maximum
9. Maximum Installation Temperature: 300°C
10. Supplied with 60/40 solder preform for easy installation
11. Insertion Loss for the “C” and “L” circuits are equivalent due to the saturation characteristic of the ferrite bead element at full rated current. At lower currents the “L” becomes much more effective.

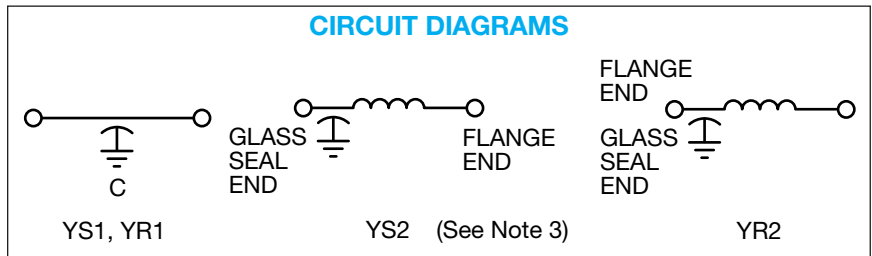
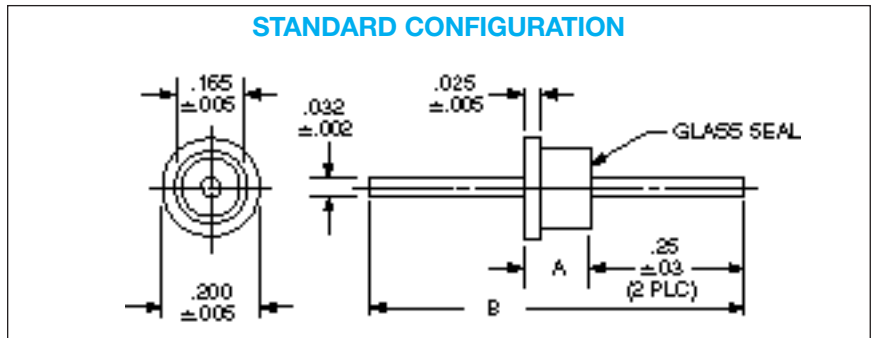

millimeters (inches)	
0.05 (.002)	4.19 (.165)
0.13 (.005)	5.08 (.200)
0.64 (.025)	6.35 (.250)
0.8 (.03)	16.51 (.650)
0.81 (.032)	19.05 (.750)
3.81 (.150)	— —

(See Note 4)

Circuit Diagram	Dimensions	
	A ±.005	B Ref.
L	.250	.750
C	.150	.650

Notes:

1. Outline drawing shows standard YS configuration. Also available with glass seal at the opposite end, YR reverse configuration.
2. MIL-F-28861/15 style A equivalent to standard YS configuration. Style B is reverse YR configuration.
3. For YS2 or YR2 L-Section Filters inductor always positioned at epoxy-filled end.
4. Metric equivalent dimensions given for information only.

MIL-F-28861/15 (See Note 2)

Dash No.	Config.
001 through 004	A
005 through 008	B

Solder-In Style High Temp EMI Filters

YS/YR Series – .165 Dia. – Circuits Available – C & L

SPECIFICATIONS

AVX P/N	Current (A)	CKT	DC Voltage	CAP Min.	Insertion Loss ¹ Per MIL-STD-220, +25°C					
					500 KHz	1 MHz	10 MHz	100 MHz	1000 MHz	10 GHz
YS1C2-152H	5	C	50	1500 pF	–	–	5	21	42	55
YS1C2-502H	5	C	50	5000 pF	–	–	15	34	50	60
YS1C2-103H	5	C	50	0.010 µF	–	4	20	35	53	60
YS1C2-153H	5	C	50	0.015 µF	–	7	25	40	55	60
YS1C2-203H	5	C	50	0.020 µF	–	8	27	41	60	65
YS1C2-273H	5	C	50	0.027 µF	4	10	30	42	65	70
YS1C2-503H	5	C	50	0.050 µF	9	15	35	44	70	70
YS1C2-753H	5	C	50	0.075 µF	12	18	37	46	70	70
YS1C2-104H	5	C	50	0.100 µF	14	20	38	48	70	70
YS2C2-152H	5	L	50	1500 pF	–	–	6	22	48	55
YS2C2-502H	5	L	50	5000 pF	–	–	15	35	55	60
YS2C2-103H	5	L	50	0.010 µF	–	4	20	36	57	60
YS2C2-153H	5	L	50	0.015 µF	–	7	25	45	60	60
YS2C2-203H	5	L	50	0.020 µF	–	8	27	46	62	65
YS2C2-273H	5	L	50	0.027 µF	4	10	30	48	65	70
YS2C2-503H	5	L	50	0.050 µF	9	15	36	50	70	70
YS2C2-753H	5	L	50	0.075 µF	12	18	37	51	70	70
YS2C2-104H	5	L	50	0.100 µF	14	20	39	52	70	70
YS1A2-152H	5	C	100	1500 pF	–	–	5	21	42	55
YS1A2-502H	5	C	100	5000 pF	–	–	15	34	50	60
YS1A2-103H	5	C	100	0.010 µF	–	4	20	35	53	60
YS1A2-153H	5	C	100	0.015 µF	–	7	25	40	55	60
YS1A2-203H	5	C	100	0.020 µF	–	8	27	41	60	65
YS1A2-273H	5	C	100	0.027 µF	–	10	30	42	65	70
YS1A2-503H	5	C	100	0.050 µF	9	15	35	44	70	70
YS1A2-753H	5	C	100	0.075 µF	12	18	37	46	70	70
YS2A2-152H	5	L	100	1500 pF	–	–	6	22	48	55
YS2A2-502H	5	L	100	5000 pF	–	–	15	35	55	60
YS2A2-103H	5	L	100	0.010 µF	–	4	20	36	57	60
YS2A2-153H	5	L	100	0.015 µF	–	7	25	45	60	60
YS2A2-203H	5	L	100	0.020 µF	–	8	27	46	62	65
YS2A2-273H	5	L	100	0.027 µF	–	10	30	48	65	70
YS2A2-503H	5	L	100	0.050 µF	9	15	36	50	70	70
YS2A2-753H	5	L	100	0.075 µF	12	18	37	51	70	70

¹ Insertion loss limits are based on theoretical values.
Actual measurements may vary due to internal capacitor resonances and other design constraints.

continued

NOTE: AVX Filters' Standard configurations (e.g. ZS, YS, XS, WS) have the hermetic glass seal opposite the flange end. All parts are capable of the reverse configuration with the glass seal at the flange end. All parameters are otherwise identical. The part number changes from "S" to "R" (e.g., standard = ZS1C2-153H; reverse = ZR1C2-153H).

For special multi-unit assemblies see Multi-Component Filter Brackets section.

Solder-In Style High Temp EMI Filters

YS/YR Series – .165 Dia. – Circuits Available – C & L

SPECIFICATIONS

AVX P/N	Current (A)	CKT	DC Voltage	CAP Min.	Insertion Loss ¹ Per MIL-STD-220, +25°C					
					500 KHz	1 MHz	10 MHz	100 MHz	1000 MHz	10 GHz
YS1B2-152H	5	C	200	1500 pF	–	–	5	21	42	55
YS1B2-502H	5	C	200	5000 pF	–	–	15	34	50	60
YS1B2-103H	5	C	200	0.010 µF	–	4	20	35	53	60
YS1B2-153H	5	C	200	0.015 µF	–	7	25	40	55	60
YS1B2-203H	5	C	200	0.020 µF	–	8	27	41	60	65
YS1B2-273H	5	C	200	0.027 µF	4	10	30	42	65	70
YS2B2-152H	5	L	200	1500 pF	–	–	6	22	48	55
YS2B2-502H	5	L	200	5000 pF	–	–	15	35	55	60
YS2B2-103H	5	L	200	0.010 µF	–	4	20	36	57	60
YS2B2-153H	5	L	200	0.015 µF	–	7	25	45	60	60
YS2B2-203H	5	L	200	0.020 µF	–	8	27	46	62	65
YS2B2-273H	5	L	200	0.027 µF	4	10	30	48	65	70

¹ Insertion loss limits are based on theoretical values.

Actual measurements may vary due to internal capacitor resonances and other design constraints.

NOTE: AVX Filters' Standard configurations (e.g. ZS, YS, XS, WS) have the hermetic glass seal opposite the flange end. All parts are capable of the reverse configuration with the glass seal at the flange end. All parameters are otherwise identical. The part number changes from "S" to "R" (e.g., standard = ZS1C2-153H; reverse = ZR1C2-153H).

For special multi-unit assemblies see Multi-Component Filter Brackets section.

Solder-In Style High Temp EMI Filters **AVX**

XS/XR Series – .250 Dia. – Circuits Available – C & L

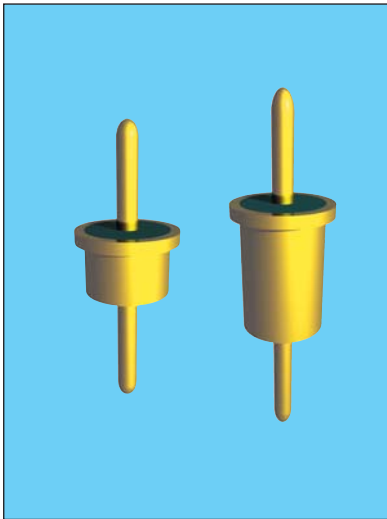

APPLICATIONS

The XS series expands upon the YS offering by providing additional filtering in the HF through MICROWAVE frequency spectrum from 500 KHz up to 10 GHz. The larger diameter of the XS series means that even higher values of capacitance and a rated DC current of 10 Amps are available. Designed to be soldered into a package, bracket or bulkhead (and maintain hermeticity), it is ideal for medium to high impedance circuits where significant amounts of capacitance to

ground can be tolerated. In the “L” section version an internal ferrite bead element provides both inductance and series resistance (lossy characteristic) which improves insertion loss and provides superior transient performance.

Alternate lead lengths or special capacitance values may be ordered.

Custom packages or bracket assemblies utilizing this feedthru can be furnished to your specifications.

CHARACTERISTICS

- Meets or exceeds the applicable portions of MIL-F-28861/14. See QPL listings.
- High temperature construction withstands 300°C installation temperatures.
- Features rugged monolithic discoidal capacitor construction.
- Glass hermetic seal on one end with epoxy seal on the opposite end.
- High purity gold plating provides excellent solderability or compatibility with thermal and ultrasonic wire bonding.

SPECIFICATIONS

1. Plating: Gold standard – Silver available
2. Material:
Case: Cold rolled steel
Leads: Alloy 52 steel
3. Operating Temperature Range:
-55°C to +125°C
4. Insulation Resistance:
At 25°C: 1,000 megohm-microfarad min., or 100,000 megohms min., whichever is less
At 125°C: 100 megohm-microfarad min., or 10,000 megohms min., whichever is less
5. Dielectric Withstanding Voltage (DWW):
R-level designs:
2.0 times rated DC voltage
Class B, Class S designs:
2.5 times rated DC voltage
6. DC Resistance (DCR): .01 ohm, maximum
7. Dissipation Factor (DF): 3% maximum
8. Rated DC Current: 5 Amps, maximum
9. Maximum Installation Temperature: 300°C
10. Supplied with 60/40 solder preform for easy installation
11. Insertion Loss for the “C” and “L” circuits are equivalent due to the saturation characteristic of the ferrite bead element at full rated current. At lower currents the “L” becomes much more effective.

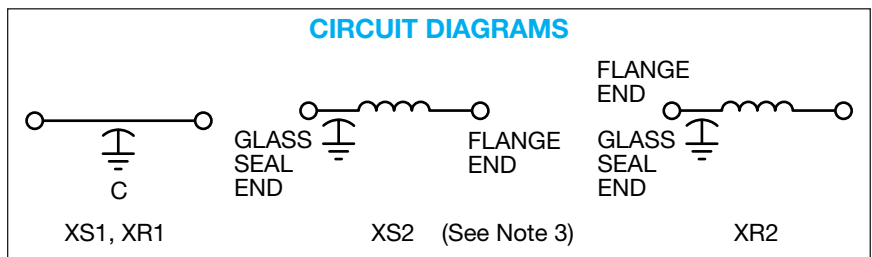
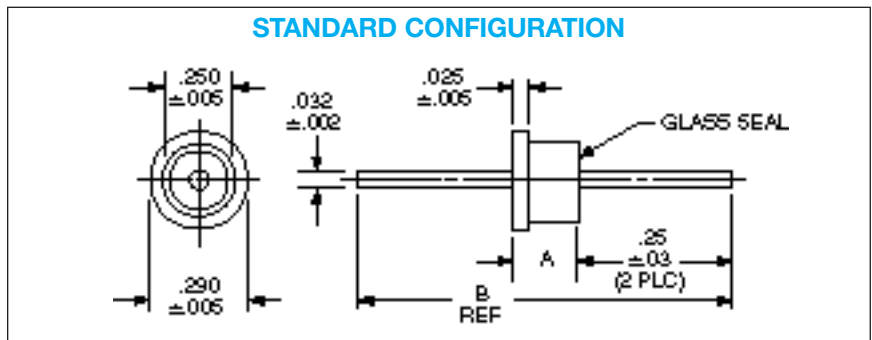

millimeters (inches)

0.05 (.002)	3.81 (.150)
0.13 (.005)	6.35 (.250)
0.64 (.025)	7.37 (.290)
0.8 (.03)	16.51 (.650)
0.81 (.032)	19.05 (.750)

(See Note 4)

Circuit Diagram	Dimensions	
	A ±.005	B Ref.
L	.250	.750
C	.150	.650

Notes:

1. Outline drawing shows standard XS configuration. Also available with glass seal at the opposite end, XR reverse configuration.
2. MIL-F-28861/14 configuration A is equivalent to standard XS configuration. B is reverse XR configuration.
3. For XS2 or XR2 L-Section Filters inductor always positioned at epoxy-filled end.
4. Metric equivalent dimensions given for information only.

MIL-F-28861/14 (See Note 2)

Dash No.	Config.
001 through 006	A STD
007 through 012	B REV

Solder-In Style High Temp EMI Filters

XS/XR Series – .250 Dia. – Circuits Available – C & L

SPECIFICATIONS

AVX P/N	Current (A)	CKT	DC Voltage	CAP Min.	Insertion Loss ¹ Per MIL-STD-220, +25°C					
					500 KHz	1 MHz	10 MHz	100 MHz	1000 MHz	10 GHz
XS1C2-503H	5	C	50	0.050 µF	9	15	35	44	70	70
XS1C2-753H	5	C	50	0.075 µF	12	18	37	46	70	70
XS1C2-104H	5	C	50	0.100 µF	14	20	38	48	70	70
XS1C2-154H	5	C	50	0.150 µF	17	24	38	50	70	70
XS1C2-254H	5	C	50	0.250 µF	21	31	40	55	70	70
XS2C2-503H	5	L	50	0.050 µF	9	15	36	50	70	70
XS2C2-753H	5	L	50	0.075 µF	12	18	37	51	70	70
XS2C2-104H	5	L	50	0.100 µF	14	20	39	52	70	70
XS2C2-154H	5	L	50	0.150 µF	17	26	40	53	70	70
XS2C2-254H	5	L	50	0.250 µF	21	31	40	56	70	70
XS1A2-503H	5	C	100	0.050 µF	9	15	35	44	70	70
XS1A2-753H	5	C	100	0.075 µF	12	18	37	46	70	70
XS1A2-104H	5	C	100	0.100 µF	14	20	38	48	70	70
XS2A2-503H	5	L	100	0.050 µF	9	15	36	50	70	70
XS2A2-753H	5	L	100	0.075 µF	12	18	37	51	70	70
XS2A2-104H	5	L	100	0.100 µF	14	20	39	52	70	70
XS1B2-153H	5	C	200	0.015 µF	–	5	25	40	55	60
XS1B2-223H	5	C	200	0.022 µF	2	8	26	40	58	70
XS2B2-153H	5	L	200	0.015 µF	–	5	25	45	60	60
XS2B2-223H	5	L	200	0.022 µF	2	8	27	45	65	70
XS1L2-103H	5	C	300	0.010 µF	–	3	20	35	52	60
XS2L2-103H	5	L	300	0.010 µF	–	3	20	38	55	60

¹ Insertion loss limits are based on theoretical values.

Actual measurements may vary due to internal capacitor resonances and other design constraints.

NOTE: AVX Filters' Standard configurations (e.g. ZS, YS, XS, WS) have the hermetic glass seal opposite the flange end. All parts are capable of the reverse configuration with the glass seal at the flange end. All parameters are otherwise identical. The part number changes from "S" to "R" (e.g., standard = ZS1C2-153H; reverse = ZR1C2-153H).

For special multi-unit assemblies see Multi-Component Filter Brackets section.

Solder-In Style High Temp EMI Filters **AVX**

WS/WR Series – .400 Dia. – Circuits Available – C & L

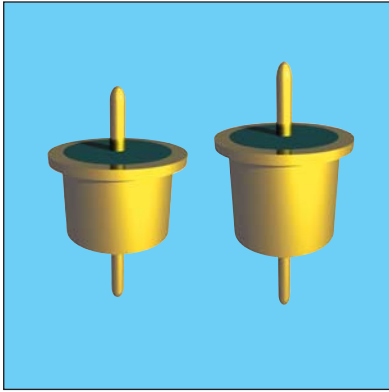

APPLICATIONS

The WS series expands greatly upon the XS and YS offerings by providing increased filtering in the HF through MICROWAVE frequency spectrum from 500 KHz up to 10 GHz. The larger diameter of the WS series means even higher values of capacitance, a rated DC current of 15 Amps, plus 125 VAC/400 Hz ratings are available. Designed to be soldered into a package, bracket or bulk-head (and maintain hermeticity), it is ideal for low to medium impedance circuits

where large amounts of capacitance to ground can be tolerated. In the “L” section version an internal ferrite bead element provides both inductance and series resistance (lossy characteristic) which improves insertion loss and provides superior transient performance.

Alternate lead lengths or special capacitance values may be ordered.

Custom packages or bracket assemblies utilizing this feedthru can be furnished to your specifications.

CHARACTERISTICS

- Meets or exceeds the applicable portions of MIL-F-28861/13. See QPL listings.
- High temperature construction withstands 300°C installation temperatures.
- Features rugged monolithic discoidal capacitor construction.
- Glass hermetic seal on one end with epoxy seal on the opposite end.
- High purity gold plating provides excellent solderability or compatibility with thermal and ultrasonic wire bonding.

SPECIFICATIONS

1. Plating: Gold standard – Silver available
2. Material:
Case: Cold rolled steel
Leads: Alloy 52 steel
3. Operating Temperature Range:
-55°C to +125°C
4. Insulation Resistance:
At 25°C: 1,000 megohm-microfarad min., or 100,000 megohms min., whichever is less
At 125°C: 100 megohm-microfarad min., or 10,000 megohms min., whichever is less
5. Dielectric Withstanding Voltage (DWW):
R-level designs:
2.0 times rated DC voltage
Class B, Class S designs:
2.5 times rated DC voltage
6. DC Resistance (DCR): .01 ohm, maximum
7. Dissipation Factor (DF): 3% maximum
8. Rated DC Current: 15 Amps, maximum
9. Maximum Installation Temperature: 300°C
10. Supplied with 60/40 solder preform for easy installation
11. Insertion Loss for the “C” and “L” circuits are equivalent due to the saturation characteristic of the ferrite bead element at full rated current. At lower currents the “L” becomes much more effective.

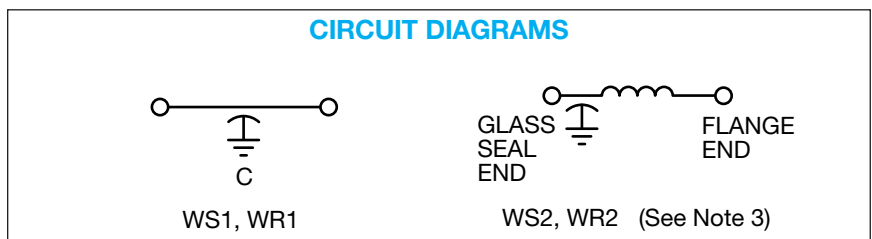
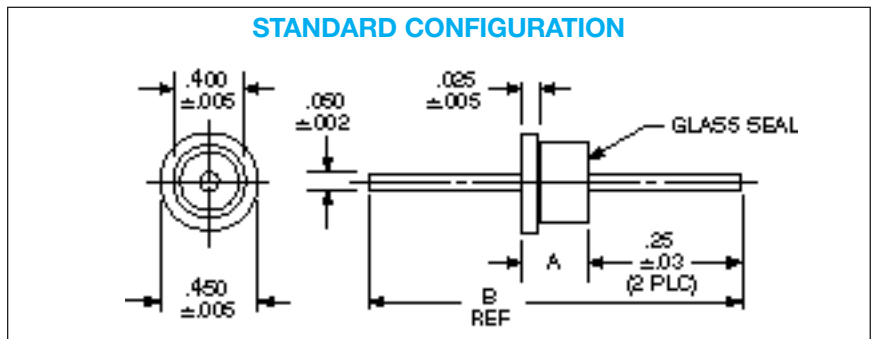

millimeters (inches)

0.05 (.002)	6.35 (.250)
0.13 (.005)	7.62 (.300)
0.64 (.025)	10.16 (.400)
0.8 (.03)	11.43 (.450)
1.27 (.050)	17.78 (.700)
5.08 (.200)	20.32 (.800)

(See Note 4)

Circuit Diagram	Dimensions	
	A ±.005	B Ref.
L	.300	.800
C	.200	.700

Notes:

1. Outline drawing shows standard WS configuration. Also available with glass seal at the opposite end, WR reverse configuration.
2. MIL-F-28861/13 configuration “A” is equivalent to standard WS configuration. “B” is reverse WR configuration.
3. For WS2 or WR2 L-Section Filters inductor always positioned at epoxy-filled end.
4. Metric equivalent dimensions given for information only.

MIL-F-28861/13 (See Note 2)

Dash No.	Config.
001 through 008	A
009 through 016	B

Solder-In Style High Temp EMI Filters

WS/WR Series – .400 Dia. – Circuits Available – C & L

SPECIFICATIONS

AVX P/N	Current (A)	Circuit	DC Voltage	CAP Min.	Insertion Loss ¹ Per MIL-STD-220, +25°C					
					500 KHz	1 MHz	10 MHz	100 MHz	1000 MHz	10 GHz
WS1C2-154H	15	C	50	0.150 µF	17	24	38	50	70	70
WS1C2-504H	15	C	50	0.500 µF	26	34	42	58	70	70
WS1C2-754H	15	C	50	0.750 µF	31	37	43	62	70	70
WS1C2-125H	15	C	50	1.200 µF	33	37	52	70	70	70
WS2C2-154H	15	L	50	0.150 µF	17	26	40	53	70	70
WS2C2-504H	15	L	50	0.500 µF	26	36	44	60	70	70
WS2C2-754H	15	L	50	0.750 µF	31	40	44	64	70	70
WS2C2-125H	15	L	50	1.200 µF	33	38	53	70	70	70
WS1N2-704H	15	C	70	0.700 µF	30	36	41	60	70	70
WS2N2-704H	15	L	70	0.700 µF	30	38	42	62	70	70
WS1A2-154H	15	C	100	0.150 µF	17	24	38	50	70	70
WS1A2-504H	15	C	100	0.500 µF	26	34	42	58	70	70
WS1A2-754H	15	C	100	0.750 µF	31	37	43	62	70	70
WS1A2-105H	15	C	100	1.000 µF	31	40	48	64	70	70
WS2A2-154H	15	L	100	0.150 µF	17	26	40	53	70	70
WS2A2-504H	15	L	100	0.500 µF	26	34	44	60	70	70
WS2A2-754H	15	L	100	0.750 µF	31	40	44	64	70	70
WS2A2-105H	15	L	100	1.000 µF	31	41	50	65	70	70
WS1L2-503H	15	C	200*	0.050 µF	7	15	34	42	70	70
WS1L2-154H	15	C	200*	0.150 µF	17	24	38	50	70	70
WS2L2-503H	15	L	200*	0.050 µF	7	15	34	44	70	70
WS2L2-154H	15	L	200*	0.150 µF	17	26	40	53	70	70
WS1E2-103H	15	C	400	0.010 µF	–	4	20	34	50	60
WS1E2-503H	15	C	400	0.050 µF	7	15	34	44	70	70
WS2E2-103H	15	L	400	0.010 µF	–	4	20	35	55	60
WS2E2-503H	15	L	400	0.050 µF	7	15	34	44	70	70

* Rated 200 VDC or 125 VAC/400 Hz.

¹ Insertion loss limits are based on theoretical values. Actual measurements may vary due to internal capacitor resonances and other design constraints.

NOTE: AVX Filters' Standard configurations (e.g. ZS, YS, XS, WS) have the hermetic glass seal opposite the flange end. All parts are capable of the reverse configuration with the glass seal at the flange end. All parameters are otherwise identical. The part number changes from "S" to "R" (e.g., standard = ZS1C2-153H; reverse = ZR1C2-153H).

For special multi-unit assemblies see Multi-Component Filter Brackets section.

Advanced Technology Filters



Miniature, Subminiature & Microminiature

APPLICATIONS

AVX's Miniature filter line breaks the "small" size barrier. These ultraminiature products, available as solder-in or screw-in style, have case diameters as low as .073". Threaded filters will allow substitution, flexibility of placement and simple installation, while solder-in parts will provide hermeticity of your microcircuit packages. Now, with capacitance values of up to 50,000 pF, "C", "L" or "T" circuits, superior insertion loss over on-board filtering, variety of ultra small and lightweight sizes, you can meet all "mission critical" objectives. World's smallest and most complete miniature EMI filter line is especially well suited for microwave industry, medical electronics, avionics instrumentation, satellites or other applications where space is at premium.

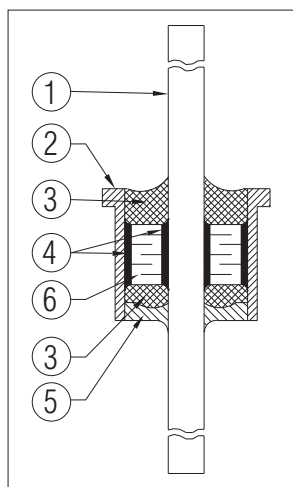
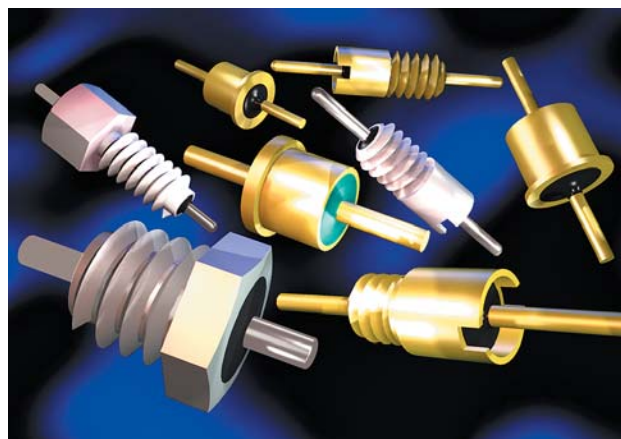

FEATURES

- World's smallest filters, a "must" for avionics and space industry.
- Tiny size for miniaturization of microwave and telecom equipment.
- Hardware real-estate and weight reduction of up to 60%.
- Most complete product offering with solder-in or bolt installation.
- Discoidal capacitor design to meet cost/reliability goals.

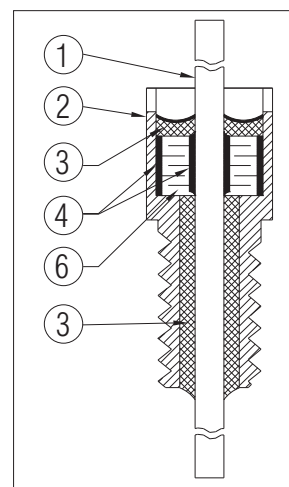

① - LEAD	② - CASE	③ - EPOXY
④ - SOLDER	⑤ - GLASS SEAL	⑥ - CAPACITOR



NOTE: Torque limiting tool with custom adapter available upon request.

SPECIFICATIONS

Mechanical

Material: Solder-In: Case and Leads:
Kovar per ASTM F-15
Screw-in: Case: CRS per ASTM-108
Leads: Copper clad steel
(1-64 & 2-56 Thd.)
Copper (4-40 & 8-36 Thd.)

Finish: Solder-in: Gold per Mil-G-45204
Screw-in: Gold per Mil-G-45204 (standard)
Silver optional (1-64 & 2-56 Thd.)
Silver per QQ-S-365 (standard)
Gold optional (4-40 & 8-36 Thd.)

Electrical

Capacitance: measured @ 1KHz and .1 to 1 VRMS, 25°C
Dissipation factor: 3% max.
Insulation resistance: 10,000 Mohms min. @ 25°C, WVDC;
1000 Mohms min. @ 125°C, WVDC
DC resistance: .02 ohm max.
Dielectric withstanding voltage: 200% of WVDC min.

EMI Filters



Miniature, Subminiature & Microminiature

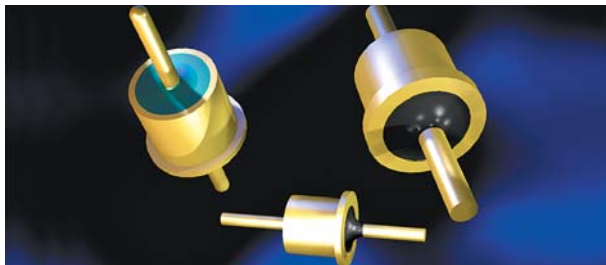

SPECIFICATIONS

AVX Part Number	Voltage Vdc (V)	Min. Cap (pF)	Current Idc (A)	MINIMUM NO LOAD INSERTION LOSS (db) @ 25°C PER MIL-STD-220					
				10 MHZ	30 MHZ	100 MHZ	300 MHZ	1 GHZ	10 GHZ
ZXS1C3-502	50	5000	1.5	15	22	35	45	55	60
ZXS1C3-272	50	2700	1.5	10	17	30	38	50	60
ZXS1A3-152	100	1500	1.5	5	12	25	33	45	55
ZXS1A3-102	100	1000	1.5	4	10	22	30	42	55
ZXS1A3-501	100	500	1.5	-	-	15	25	35	50
ZXS1A3-251	100	250	1.5	-	-	10	17	27	40
ZXS1B3-101	200	100	1.5	-	-	3	10	20	30
ZXS1B3-500	200	50	1.5	-	-	1	6	15	25
ZXS1B3-250	200	25	1.5	-	-	-	1	10	22
ZXS1B3-100	200	10	1.5	-	-	-	-	3	20
ZXS1B3-5R0	200	5	1.5	-	-	-	-	-	15
ZXS1B3-000	200	2 max.	1.5	-	-	-	-	-	-
ZYS1C3-273	50	27000	2.5	30	37	43	53	65	70
ZYS1C3-103	50	10000	2.5	20	27	37	47	60	65
ZYS1A3-502	100	5000	2.5	15	22	35	45	55	60
ZYS1A3-272	100	2700	2.5	10	17	30	38	50	60
ZYS1A3-152	100	1500	2.5	5	12	25	33	45	55
ZYS1B3-102	200	1000	2.5	4	10	22	30	42	55
ZYS1B3-501	200	500	2.5	-	-	15	25	35	50
ZYS1B3-251	200	250	2.5	-	-	10	17	27	40
ZYS1B3-101	200	100	2.5	-	-	3	10	20	30
ZYS1B3-500	200	50	2.5	-	-	1	6	15	25
ZYS1B3-250	200	25	2.5	-	-	-	1	10	22
ZYS1B3-100	200	10	2.5	-	-	-	-	3	20
ZYS1B3-5R0	200	5	2.5	-	-	-	-	-	15
ZYS1B3-000	200	2 max.	2.5	-	-	-	-	-	-
ZZS1C3-503	50	50000	5	35	40	45	55	70	70
ZZS1C3-273	50	27000	5	30	37	43	53	65	70
ZZS1A3-103	100	10000	5	20	27	37	47	60	65
ZZS1B3-502	200	5000	5	15	22	35	45	55	60
ZZS1B3-272	200	2700	5	10	17	30	38	50	60
ZZS1B3-152	200	1500	5	5	12	25	33	45	55
ZZS1B3-102	200	1000	5	4	10	22	30	42	55
ZZS1B3-501	200	500	5	-	-	15	25	35	50
ZZS1B3-251	200	250	5	-	-	10	17	27	40
ZZS1B3-101	200	100	5	-	-	3	10	20	30
ZZS1B3-500	200	50	5	-	-	1	6	15	25
ZZS1B3-250	200	25	5	-	-	-	1	10	22
ZZS1B3-100	200	10	5	-	-	-	-	3	20
ZZS1B3-5R0	200	5	5	-	-	-	-	-	15
ZZS1B3-000	200	2 max.	5	-	-	-	-	-	-

NOTE: Dimensions in inches (millimeters).

Terminals

Flattened at Glass Seal End Only

Configuration Options

Glass Seal

- Opposite Flange End – Standard
- At Flange End – Reversed

Change 3rd letter of part number from "S" to "R" for reversed configuration

Schematic

- "C" STANDARD
- "L1" AVAILABLE WITH EXTENDED CASE LENGTH

Bolt Style EMI Filters

SA Series – 4-40 Thread - Epoxy Sealed – Circuits Available – C & L

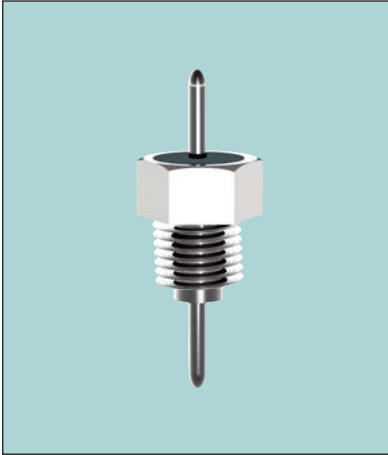

APPLICATIONS

The SA series provides effective filtering in the RF and MICROWAVE frequency spectrums from 10 MHz through 26 GHz. Designed for mounting in a tapped bulkhead or with the standard nut and lockwasher provided, it is ideal for high impedance circuits where large capacitance values are not practical. In the “L” section version an internal ferrite bead

element provides both inductance and series resistance (lossy characteristic) which improves insertion loss and provides superior transient performance. The SA series comes with a standard .020 diameter beryllium copper lead. Alternate lead lengths, diameters of .016 or .026 and alternate materials in steel or half-hard copper are available.

CHARACTERISTICS

- Meets or exceeds the applicable portions of MIL-F-28861/6. See QPL listings.
- Smallest screwbody filter available.
- Features rugged monolithic discoidal capacitor construction.
- Epoxy seal on both ends.

SPECIFICATIONS

1. Plating: Silver standard – Electro-tin or gold available
2. Material:
 - Case: Cold rolled steel
 - Leads: Beryllium copper (steel or half/hard copper leads available)
3. Operating Temperature Range: -55°C to +125°C
4. Insulation Resistance:
 - At 25°C: 1,000 megohm-microfarad min., or 100,000 megohms min., whichever is less
 - At 125°C: 100 megohm-microfarad min., or 10,000 megohms min., whichever is less
5. Dielectric Withstanding Voltage (DWW):
 - R-level designs: 2.0 times rated DC voltage
 - Class B, Class S designs: 2.5 times rated DC voltage
6. DC Resistance (DCR): .02 ohm, maximum
7. Dissipation Factor (DF): 3% maximum
8. Rated DC Current: 5 Amps, maximum
9. Recommended Mounting Torque: 32 oz-in. ± 4 oz-in.
10. Supplied with mounting nut and lockwasher - See Filter Design Guide Screw and Locking Washer Table
11. Insertion Loss for the “C” and “L” sections are equivalent due to the saturation characteristic of the ferrite bead element at rated current. At lower currents the “L” becomes much more effective.

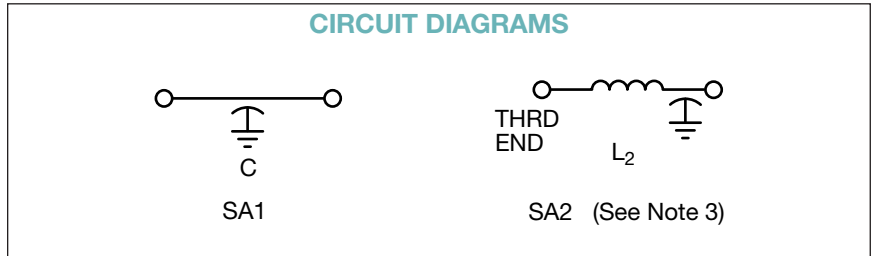
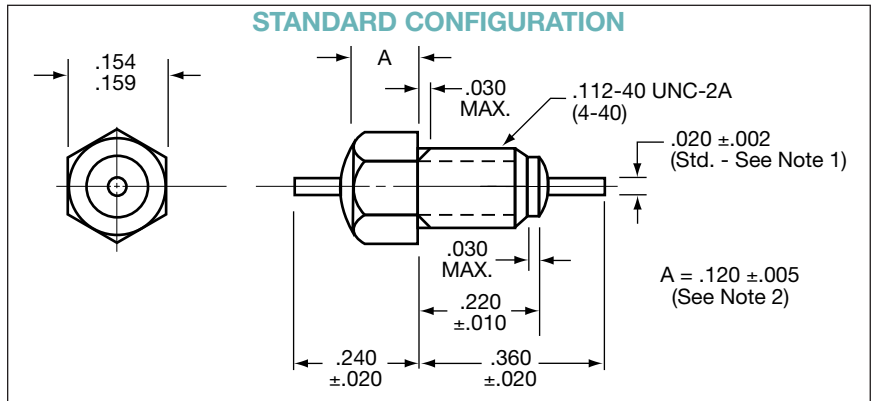

millimeters (inches)	
0.05 (.002)	3.05 (.120)
0.13 (.005)	3.68 (.145)
0.25 (.010)	3.91 (.154)
0.41 (.016)	4.04 (.159)
0.51 (.020)	5.59 (.220)
0.66 (.026)	6.10 (.240)
0.76 (.030)	9.14 (.360)
2.84 (.112)	— —

(See Note 4)

Notes:

1. Standard catalog designs have .020" dia. lead. MIL-F-28861/6 calls for .026" dia. .026" dia. will not be supplied unless specified.
2. "A" dimension of .120 ± .005 will satisfy M28861/6-003 requirement for .145 ± .030. All "SA" series are supplied A = .120 ± .005.
3. All SA2 L-Section Filters have inductor (bead) at threaded end.
4. Metric equivalent dimensions given for information only.

Bolt Style EMI Filters

SA Series – 4-40 Thread - Epoxy Sealed – Circuits Available – C & L



SPECIFICATIONS

AVX P/N	CKT	CAP	DC Voltage	DCR (Ω)	Insertion Loss ¹ Per MIL-STD-220, +25°C					
					1 MHz	10 MHz	100 MHz	200 MHz	1 GHz	10 GHz
SA1C1-102	C	1000 pF	50	0.020	–	4	20	25	25	55
SA1C1-502	C	5000 pF	50	0.020	–	15	34	41	42	55
SA1C1-103	C	0.010 μ F	50	0.020	4	21	35	42	50	70
SA1C1-273	C	0.027 μ F	50	0.020	10	30	39	43	65	70
SA1C1-503	C	0.050 μ F	50	0.020	15	35	42	45	70	70
SA2C1-102	L2	1000 pF	50	0.020	–	4	20	27	30	60
SA2C1-502	L2	5000 pF	50	0.020	–	15	35	41	45	60
SA2C1-103	L2	0.010 μ F	50	0.020	4	21	35	44	50	70
SA2C1-273	L2	0.027 μ F	50	0.020	10	30	50	45	65	70
SA2C1-503	L2	0.050 μ F	50	0.020	15	37	45	45	70	70
SA1A1-102	C	1000 pF	100	0.020	–	4	20	25	25	55
SA1A1-502	C	5000 pF	100	0.020	–	15	35	41	42	55
SA1A1-103	C	0.010 μ F	100	0.020	4	21	35	42	50	70
SA1A1-273	C	0.027 μ F	100	0.020	10	30	39	43	65	70
SA1A1-453	C	0.045 μ F	100	0.020	14	35	42	45	70	70
SA2A1-102	L2	1000 pF	100	0.020	–	4	20	27	30	60
SA2A1-502	L2	5000 pF	100	0.020	–	15	35	41	45	60
SA2A1-103	L2	0.010 μ F	100	0.020	4	21	35	44	50	70
SA2A1-273	L2	0.027 μ F	100	0.020	10	30	50	45	70	70
SA2A1-453	L2	0.045 μ F	100	0.020	14	37	45	45	70	70
SA1B1-102	C	1000 pF	200	0.020	–	4	20	25	25	55
SA1B1-502	C	5000 pF	200	0.020	–	15	34	41	42	55
SA1B1-103	C	0.010 μ F	200	0.020	4	21	35	42	50	70
SA2B1-102	L2	1000 pF	200	0.020	–	4	20	27	30	60
SA2B1-502	L2	5000 pF	200	0.020	–	15	35	41	45	60
SA2B1-103	L2	0.010 μ F	200	0.020	4	21	35	44	50	70

¹ Insertion loss limits are based on theoretical values.
Actual measurements may vary due to internal capacitor resonances and other design constraints.

Bolt Style EMI Filters

SB Series – 8-32 Thread - Epoxy Sealed –

Circuits Available – C, L, π

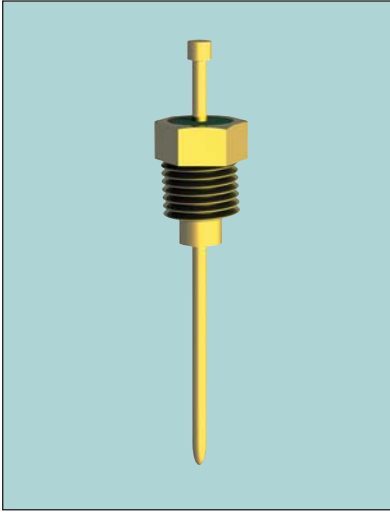

APPLICATIONS

The SB series provides improved filtering in the HF through MICROWAVE frequency spectrums from 1 MHz through 10 GHz. Also designed for mounting in a tapped bulkhead or with the standard nut and lockwasher provided, it is ideal for medium to high impedance circuits where large

capacitance values are not practical. In the “L” and “ π ” section versions an internal ferrite bead element provides both inductance and series resistance (lossy characteristic) which improves the insertion loss rolloff to 40 dB and 60 dB per decade respectively.

CHARACTERISTICS

- Designed to meet or exceed the applicable portions of MIL-F-28861/7. See QPL listings.
- π design offers steeper insertion loss rolloff.
- Features rugged monolithic discoidal capacitor construction.
- Epoxy seal on both ends.

SPECIFICATIONS

1. Plating: Silver standard – Electro-tin or gold available
2. Material:
Case: Cold rolled steel
Leads: Half/hard copper
3. Operating Temperature Range:
-55°C to +125°C
4. Insulation Resistance:
At 25°C: 1,000 megohm-microfarad min., or 100,000 megohms min., whichever is less
At 125°C: 100 megohm-microfarad min., or 10,000 megohms min., whichever is less
5. Dielectric Withstanding Voltage (DWW):
R-level designs:
2.0 times rated DC voltage
Class B, Class S designs:
2.5 times rated DC voltage
6. DC Resistance (DCR): .01 ohm, maximum
7. Dissipation Factor (DF): 3% maximum
8. Rated DC Current: 10 Amps, maximum
9. Recommended Mounting Torque:
64 oz-in. \pm 4 oz-in.
10. Supplied with mounting nut and lockwasher - See Filter Design Guide Screw and Locking Washer Table
11. Insertion Loss for the “C”, “L” and “ π ” circuits are equivalent due to the saturation characteristic of the ferrite bead element at full rated current. At lower currents the “L” and “ π ” become much more effective.

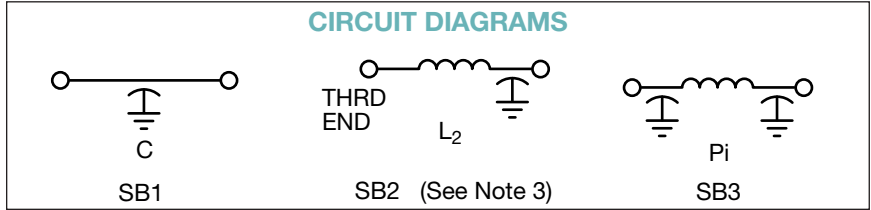
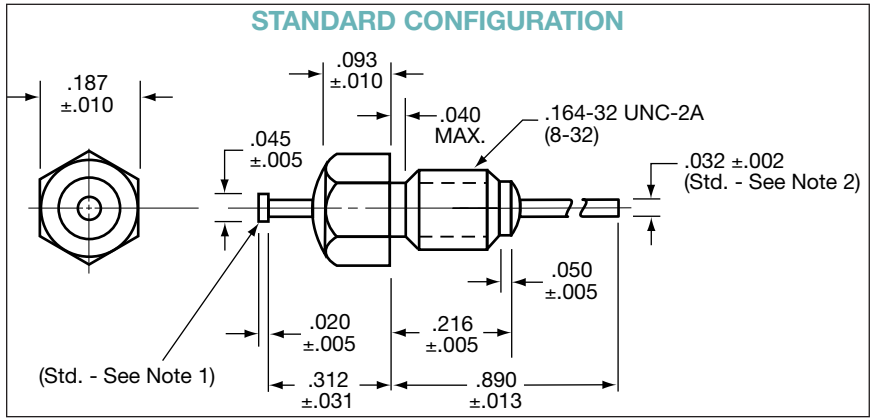

millimeters (inches)

0.05 (.002)	1.14 (.045)
0.13 (.005)	1.27 (.050)
0.18 (.007)	1.85 (.073)
0.25 (.010)	2.36 (.093)
0.33 (.013)	4.17 (.164)
0.38 (.015)	4.75 (.187)
0.51 (.020)	5.49 (.216)
0.64 (.025)	6.35 (.250)
0.76 (.030)	7.11 (.280)
0.79 (.031)	7.92 (.312)
0.81 (.032)	22.61 (.890)
1.02 (.040)	—

(See Note 4)

Notes:

1. Nailhead standard, straight lead available.
2. Lead diameters other than .032" available.
3. All SB2 L-Section Filters have inductor (bead) at threaded end.
4. Metric equivalent dimensions given for information only.

Bolt Style EMI Filters

SB Series – 8-32 Thread - Epoxy Sealed – Circuits Available – C, L, π



SPECIFICATIONS

AVX P/N	CKT	CAP	DC Voltage	DCR (Ω)	Insertion Loss ¹ Per MIL-STD-220, +25°C					
					1 MHz	10 MHz	100 MHz	200 MHz	1 GHz	10 GHz
SB1C1-102	C	1000 pF	50	0.010	–	4	20	25	40	50
SB1C1-502	C	5000 pF	50	0.010	–	15	34	41	50	55
SB1C1-103	C	0.010 μ F	50	0.010	4	21	35	40	55	60
SB1C1-273	C	0.027 μ F	50	0.010	10	30	39	45	65	70
SB1C1-503	C	0.050 μ F	50	0.010	15	35	42	50	70	70
SB2C1-273	L2	0.027 μ F	50	0.010	10	30	50	54	65	70
SB2C1-503	L2	0.050 μ F	50	0.010	15	36	54	60	70	70
SB3C1-323	π	0.032 μ F	50	0.010	12	30	60	70	70	70
SB1A1-102	C	1000 pF	100	0.010	–	4	20	25	40	50
SB1A1-502	C	5000 pF	100	0.010	–	15	34	41	50	55
SB1A1-103	C	0.010 μ F	100	0.010	4	21	35	40	55	60
SB1A1-273	C	0.027 μ F	100	0.010	10	30	39	45	65	70
SB1A1-503	C	0.050 μ F	100	0.010	15	35	42	50	70	70
SB2A1-103	L2	0.010 μ F	100	0.010	4	21	35	38	65	70
SB2A1-273	L2	0.027 μ F	100	0.010	10	30	50	54	70	70
SB3A1-152	π	1500 pF	100	0.010	–	8	20	45	70	70
SB3A1-123	π	0.012 μ F	100	0.010	–	12	60	70	70	70
SB3A1-153	π	0.015 μ F	100	0.010	–	17	37	43	70	70
SB1B1-102	C	1000 pF	200	0.010	–	4	20	25	40	50
SB1B1-502	C	5000 pF	200	0.010	–	15	34	41	50	55
SB2B1-102	L2	1000 pF	200	0.010	–	4	20	27	45	70
SB2B1-502	L2	5000 pF	200	0.010	–	15	35	41	55	70
SB3B1-202	π	2000 pF	200	0.010	–	8	42	58	70	70

¹ Insertion loss limits are based on theoretical values.
Actual measurements may vary due to internal capacitor resonances and other design constraints.

Bolt Style EMI Filters

SH Series – 10-32 Thread - Epoxy Sealed – Circuits Available – C, L, π

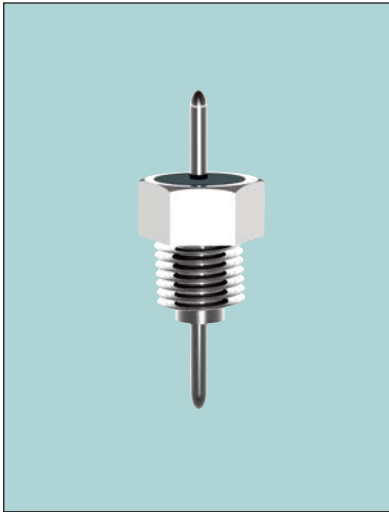

APPLICATIONS

The SH series provides intermediate filtering in the RF through MICROWAVE frequency spectrums from 100 KHz through 10 GHz. The larger hex size means that much higher values of capacitance are available in the feedthru style circuits and that a 125 VAC/400 Hz rating is available in certain values. Also designed for mounting in a tapped bulk-head or with the standard nut and lock-washer provided, it is optimum in medium

to low impedance circuits where significant amounts of capacitance to ground can be tolerated. In the “L” and “ π ” section versions an internal ferrite bead element provides both inductance and series resistance (lossy characteristic) which improves the insertion loss rolloff to 40 dB and 60 dB per decade respectively. Alternate lead diameters or lengths are available, both with and without a nailhead.

CHARACTERISTICS

- Equivalent to SB series π circuits and to SP series feedthru or “L” circuits.
- Conservatively rated for 125 VAC/400 Hz in certain values.
- π design offers steeper insertion loss rolloff.
- Features rugged monolithic discoidal capacitor construction.
- Epoxy seal on both ends.

SPECIFICATIONS

1. Plating: Silver standard – Electro-tin or gold available
2. Material:
 - Case: Cold rolled steel standard, brass available
 - Leads: Half/hard copper
3. Operating Temperature Range: -55°C to +125°C
4. Insulation Resistance:
 - At 25°C: 1,000 megohm-microfarad min., or 100,000 megohms min., whichever is less
 - At 125°C: 100 megohm-microfarad min., or 10,000 megohms min., whichever is less
5. Dielectric Withstanding Voltage (DWW):
 - R-level designs: 2.0 times rated DC voltage
 - Class B, Class S designs: 2.5 times rated DC voltage
6. DC Resistance (DCR): .01 ohm, maximum
7. Dissipation Factor (DF): 3% maximum
8. Rated DC Current: 10 Amps, maximum
9. Recommended Mounting Torque: 64 oz-in. \pm 4 oz-in.
10. Supplied with mounting nut and lock-washer - See Filter Design Guide Screw and Locking Washer Table
11. Insertion Loss for the “C”, “L” and “ π ” circuits are equivalent due to the saturation characteristic of the ferrite bead element at full rated current. At lower currents the “L” and “ π ” become much more effective.

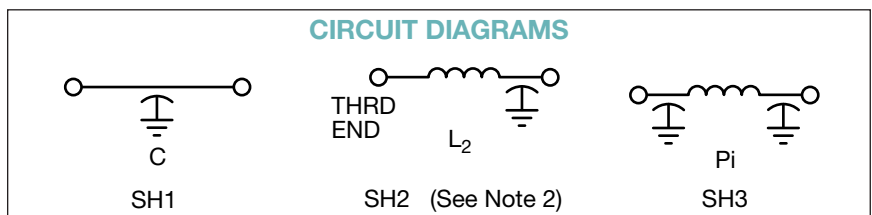
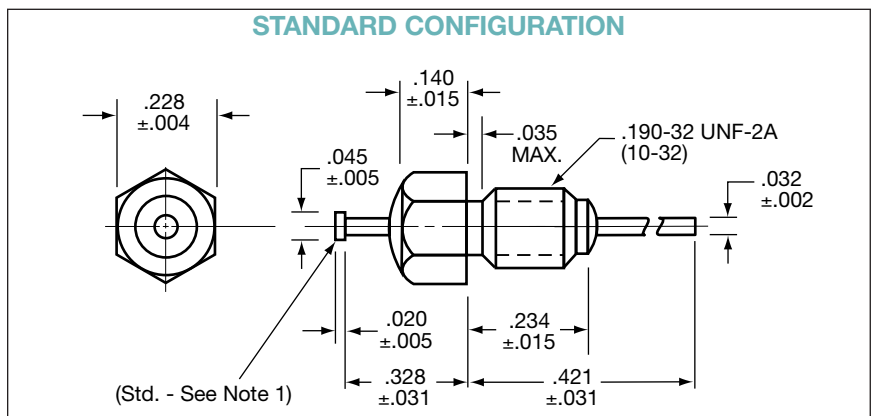

millimeters (inches)

0.05 (.002)	3.56 (.140)
0.10 (.004)	4.83 (.190)
0.13 (.005)	5.79 (.228)
0.38 (.015)	5.94 (.234)
0.51 (.020)	8.33 (.328)
0.79 (.031)	10.69 (.421)
0.81 (.032)	— —

(See Note 3)

Notes:

1. Nailhead standard, straight lead available.
2. All SH2 L-Section Filters have inductor (bead) at threaded end.
3. Metric equivalent dimensions given for information only.

Bolt Style EMI Filters

SH Series – 10-32 Thread - Epoxy Sealed – Circuits Available – C, L, π



SPECIFICATIONS

AVX P/N	CKT	CAP	DC Voltage	DCR (Ω)	Insertion Loss ¹ Per MIL-STD-220, +25°C					
					1 MHz	10 MHz	100 MHz	200 MHz	1 GHz	10 GHz
SH1C1-124	C	0.120 μ F	50	0.010	21	38	49	60	70	70
SH1C1-204	C	0.200 μ F	50	0.010	28	39	52	60	70	70
SH2C1-124	L2	0.120 μ F	50	0.010	21	38	52	70	70	70
SH2C1-204	L2	0.200 μ F	50	0.010	28	39	54	70	70	70
SH3C1-303	π	0.030 μ F	50	0.010	10	28	58	70	70	70
SH1A1-503	C	0.050 μ F	100	0.010	15	35	42	50	70	70
SH1A1-104	C	0.100 μ F	100	0.010	20	38	48	53	70	70
SH2A1-503	L2	0.050 μ F	100	0.010	15	36	50	60	70	70
SH2A1-104	L2	0.100 μ F	100	0.010	20	39	52	65	70	70
SH3A1-123	π	0.012 μ F	100	0.010	–	12	60	70	70	70
SH1L1-102	C	1000 pF	200*	0.010	–	4	20	25	40	50
SH1L1-502	C	5000 pF	200*	0.010	–	15	34	41	45	55
SH1L1-103	C	0.010 μ F	200*	0.010	4	21	35	38	60	65
SH1L1-253	C	0.025 μ F	200*	0.010	8	28	36	44	64	70
SH2L1-102	L2	1000 pF	200*	0.010	–	4	20	27	45	55
SH2L1-502	L2	5000 pF	200*	0.010	–	15	35	41	55	65
SH2L1-103	L2	0.010 μ F	200*	0.010	4	21	36	40	60	65
SH3B1-202	π	2000 pF	200	0.010	–	8	42	58	70	70

* Rated 200 VDC or 125 VAC/400 Hz

¹ Insertion loss limits are based on theoretical values.
Actual measurements may vary due to internal capacitor resonances and other design constraints.

Bolt Style EMI Filters

SP Series – 12-32 Thread - Epoxy Sealed – Circuits Available – C, L, π

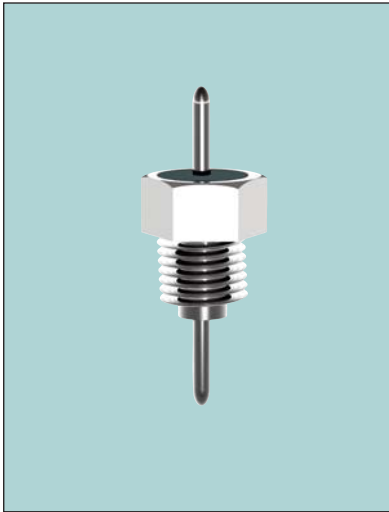

APPLICATIONS

The SP series provides increased filtering in the HF through MICROWAVE frequency spectrums from 100 KHz through 10 GHz. The larger hex size means that much higher values of capacitance are available and that a 125 VAC/400 Hz rating is available in certain values. Also designed for mounting in a tapped bulk-head or with the standard nut and lock-washer provided, it is optimum in medium

to low impedance circuits where significant amounts of capacitance to ground can be tolerated. In the “L” and “ π ” section versions an internal ferrite bead element provides both inductance and series resistance (lossy characteristic) which improves the insertion loss rolloff to 40 dB and 60 dB per decade respectively.

Alternate lead diameters or lengths are available both with and without a nailhead.

CHARACTERISTICS

- Designed to meet or exceed the applicable portions of MIL-F-28861/9. See QPL listing.
- Conservatively rated for 125 VAC/400 Hz in certain values.
- π design offers steeper insertion loss rolloff.
- Features rugged monolithic discoidal capacitor construction.
- Epoxy seal on both ends.

SPECIFICATIONS

1. Plating: Silver standard – Electro-tin or gold available
2. Material:
 - Case: Cold rolled steel standard, brass available
 - Leads: Half/hard copper
3. Operating Temperature Range: -55°C to +125°C
4. Insulation Resistance:
 - At 25°C: 1,000 megohm-microfarad min., or 100,000 megohms min., whichever is less
 - At 125°C: 100 megohm-microfarad min., or 10,000 megohms min., whichever is less
5. Dielectric Withstanding Voltage (DWW):
 - R-level designs: 2.0 times rated DC voltage
 - Class B, Class S designs: 2.5 times rated DC voltage
6. DC Resistance (DCR): .01 ohm, maximum
7. Dissipation Factor (DF): 3% maximum
8. Rated DC Current: 10 Amps, maximum
9. Recommended Mounting Torque: 64 oz-in. \pm 4 oz-in.
10. Supplied with mounting nut and lock-washer - See Filter Design Guide Screw and Locking Washer Table
11. Insertion Loss for the “C”, “L” and “ π ” circuits are equivalent due to the saturation characteristic of the ferrite bead element at full rated current. At lower currents the “L” and “ π ” become much more effective.

STANDARD CONFIGURATION

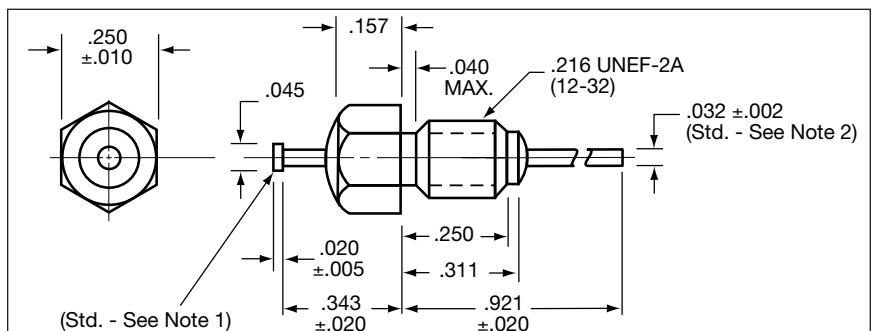

ALTERNATE CONFIGURATION (SC SERIES)

millimeters (inches)

0.05 (.002)	2.36 (.093)
0.13 (.005)	3.99 (.157)
0.18 (.007)	4.75 (.187)
0.25 (.010)	5.49 (.216)
0.51 (.020)	6.12 (.241)
0.58 (.023)	6.35 (.250)
0.79 (.031)	7.90 (.311)
0.81 (.032)	8.71 (.343)
1.02 (.040)	9.45 (.372)
1.14 (.045)	9.73 (.383)
1.60 (.063)	23.39 (.921)
1.85 (.073)	—

(See Note 4)

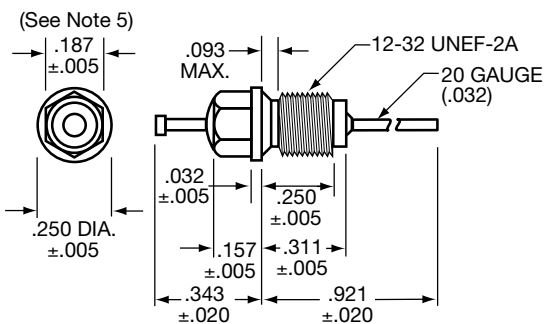

Notes:

1. Nailhead standard, straight lead available.
2. Lead diameters other than .032" available.
3. SP2 L-Section Filters have inductor (bead) at threaded end.
4. Metric equivalent dimensions given for information only.
5. Small-hex version may be specified for selected capacitance/voltage ratings. Contact AVX Filters Engineering for availability.

CIRCUIT DIAGRAMS

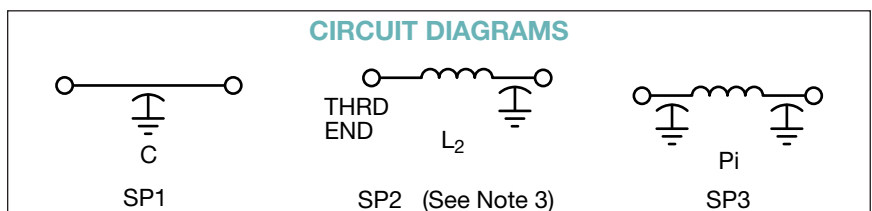

Bolt Style EMI Filters

SP Series – 12-32 Thread - Epoxy Sealed – Circuits Available – C, L, π



SPECIFICATIONS

AVX P/N	CKT	CAP	DC Voltage	DCR (Ω)	Insertion Loss ¹ Per MIL-STD-220, +25°C					
					1 MHz	10 MHz	100 MHz	200 MHz	1 GHz	10 GHz
SP1C1-204	C	0.200 μ F	50	0.010	26	39	52	60	70	70
SP2C1-204	L2	0.200 μ F	50	0.010	26	38	65	70	70	70
SP3C1-124	π	0.120 μ F	50	0.010	20	38	70	70	70	70
SP1A1-503	C	0.050 μ F	100	0.010	15	35	38	50	70	70
SP1A1-104	C	0.100 μ F	100	0.010	20	38	48	53	70	70
SP2A1-503	L2	0.050 μ F	100	0.010	15	36	54	60	70	70
SP3A1-753	π	0.075 μ F	100	0.010	18	38	70	70	70	70
SP1L1-102	C	1000 pF	200*	0.010	–	4	20	25	40	50
SP1L1-502	C	5000 pF	200*	0.010	–	15	34	41	50	55
SP1L1-103	C	0.010 μ F	200*	0.010	4	21	35	40	55	60
SP1L1-253	C	0.025 μ F	200*	0.010	8	28	36	44	64	70
SP2L1-102	L2	1000 pF	200*	0.010	–	4	20	27	45	70
SP2L1-502	L2	5000 pF	200*	0.010	–	15	35	41	55	70
SP2L1-103	L2	0.010 μ F	200*	0.010	4	21	35	38	65	70
SP3B1-152	π	1500 pF	200	0.010	–	8	20	45	70	70
SP3B1-123	π	0.012 μ F	200	0.010	–	12	60	70	70	70

* Rated 200 VDC or 125 VAC/400 Hz

¹ Insertion loss limits are based on theoretical values.
Actual measurements may vary due to internal capacitor
resonances and other design constraints.

Bolt Style EMI Filters

SN Series – 12-32 Thread - Hermetically Sealed – Circuits Available – C, L, π

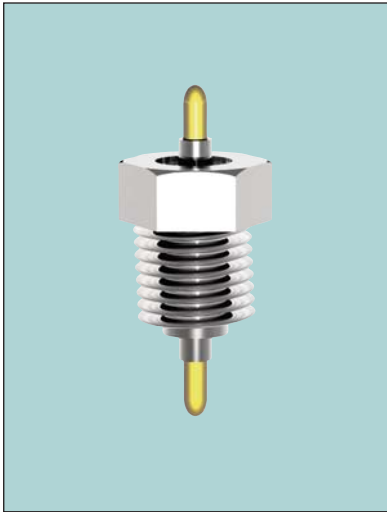

APPLICATIONS

The SN series offers effective filtering from 1 MHz to 10 GHz. Glass sealed on both ends for hermeticity, this series is impervious to high moisture, solvents, or other severe environmental conditions commonly encountered in military applications. It is designed for bulkhead mounting with nut and lockwasher supplied.

The feedthru designs yield constant filtering as current level is increased from

no-load to full rated load. They are most effective when placed in high impedance circuits. The π -section designs exhibit sharper roll-off in filter characteristic and perform effectively when used in medium to low impedance circuits.

Alternate lead configurations or special capacitance values and voltage ratings may be ordered.

CHARACTERISTICS

- The hermetic bolt-style design was developed to meet or exceed the applicable portions of MIL-F-28861/10. The filter is assembled with a glass hermetic seal on both ends. The rugged monolithic capacitor element is a low inductance design that yields superior

bypass performance. The π -section design contains two capacitor elements together with a ferrite bead inductor.

- Certain feedthru designs are rated for 115 VAC/400 Hz applications. The 200 VDC π -section design is rated for DC applications only.

SPECIFICATIONS

- Plating: Silver standard – Electro-tin or gold available
- Material:
 - Case: Cold rolled steel standard, brass available
 - Leads: Copper nailhead standard. Only available in .032" diameter. Beryllium copper lead available. Straight lead available.
- Operating Temperature Range: -55°C to +125°C
- Electrical Characteristics:
 - Capacitance: Guaranteed Minimum Value (GMV) as listed
 - Insulation Resistance:
 - At 25°C: 1,000 megohm-microfarad min., or 100,000 megohms min., whichever is less
 - At 125°C: 100 megohm-microfarad min., or 10,000 megohms min., whichever is less
 - Dielectric Withstanding Voltage (DWW):
 - R-level designs: 2.0 times rated voltage
 - Class B, Class S designs: 2.5 times rated voltage
 - DC Resistance (DCR): .01 ohm, maximum
 - Voltage Drop: 0.1 volt, maximum
 - Dissipation Factor (DF): 3% maximum
 - Rated Current: 10 Amps, maximum
- Seal: In accordance with MIL-F-28861. Leakage rate for Class S designs shall not exceed 1×10^{-7} atm cc/sec.
- Marking: Standard (AVX symbol, AVX part number)
- Installation: Filter is supplied with mounting nut and lockwasher. The recommended mounting torque is 64 oz-in. \pm 4 oz-in. Refer to the "Installation and Handling" section for additional information.

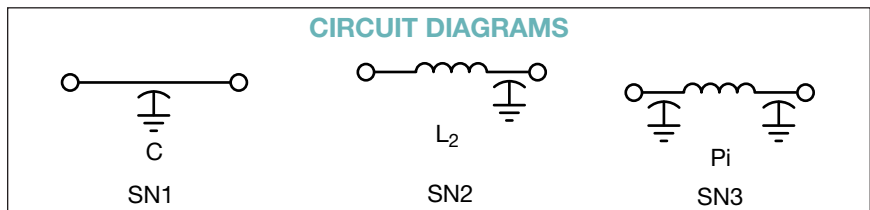
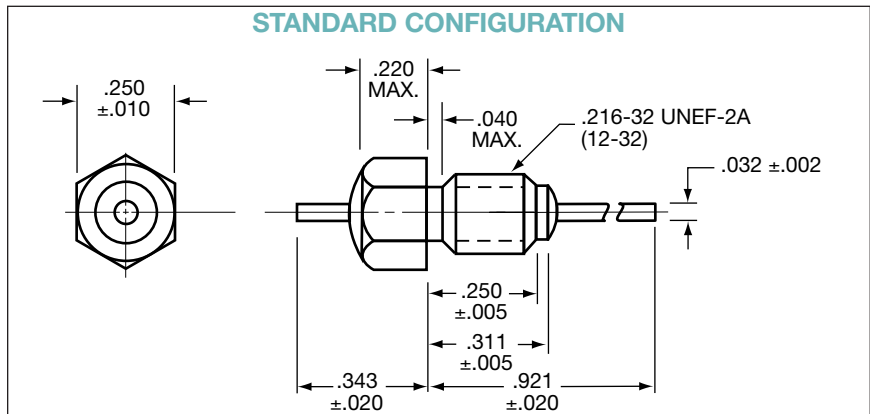

millimeters (inches)

0.05 (.002)	1.85 (.073)
0.13 (.005)	3.99 (.157)
0.18 (.007)	5.49 (.216)
0.25 (.010)	6.12 (.241)
0.51 (.020)	6.35 (.250)
0.58 (.023)	7.90 (.311)
0.79 (.031)	8.71 (.343)
0.81 (.032)	9.45 (.372)
1.02 (.040)	9.73 (.383)
1.14 (.045)	23.39 (.921)
1.60 (.063)	—

(See Note 1)

Notes:

- Metric equivalent dimensions given for information only.

Bolt Style EMI Filters

SN Series – 12-32 Thread - Hermetically Sealed – Circuits Available – C, L, π



SPECIFICATIONS

AVX P/N	CKT	CAP	Voltage	DCR (Ω)	Insertion Loss ¹ Per MIL-STD-220, +25°C					
					1 MHz	10 MHz	100 MHz	200 MHz	1 GHz	10 GHz
SN1C1-204	C	0.200 μ F	50	0.010	26	39	52	60	70	70
SN2C1-204	L2	0.200 μ F	50	0.010	26	38	65	70	70	70
SN3C1-124	π	0.120 μ F	50	0.010	20	38	70	70	70	70
SN1A1-503	C	0.050 μ F	100	0.010	15	35	42	50	70	70
SN1A1-104	C	0.100 μ F	100	0.010	20	38	48	53	70	70
SN2A1-503	L2	0.050 μ F	100	0.010	15	36	54	60	70	70
SN3A1-753	π	0.075 μ F	100	0.010	18	38	70	70	70	70
SN1L1-102	C	1000 pF	200*	0.010	–	4	20	25	40	50
SN1L1-502	C	5000 pF	200*	0.010	–	15	34	41	50	55
SN1L1-103	C	0.010 μ F	200*	0.010	4	21	35	40	55	60
SN1L1-253	C	0.025 μ F	200*	0.010	8	28	36	44	64	70
SN2L1-102	L2	1000 pF	200*	0.010	–	4	20	27	45	70
SN2L1-502	L2	5000 pF	200*	0.010	–	15	35	41	55	70
SN2L1-103	L2	0.010 μ F	200*	0.010	4	21	35	38	65	70
SN3B1-152	π	1500 pF	200	0.010	–	8	20	45	70	70
SN3B1-123	π	0.012 μ F	200	0.010	–	12	60	70	70	70

* Rated 200 VDC or 125 VAC/400 Hz

¹ Insertion loss limits are based on theoretical values.
Actual measurements may vary due to internal capacitor
resonances and other design constraints.

Advanced Technology Filters



Miniature, Subminiature & Microminiature

APPLICATIONS

AVX's Miniature filter line breaks the "small" size barrier. These ultraminiature products, available as solder-in or screw-in style, have case diameters as low as .073". Threaded filters will allow substitution, flexibility of placement and simple installation, while solder-in parts will provide hermeticity of your microcircuit packages. Now, with capacitance values of up to 50,000 pF, "C", "L" or "T" circuits, superior insertion loss over on-board filtering, variety of ultra small and lightweight sizes, you can meet all "mission critical" objectives. World's smallest and most complete miniature EMI filter line is especially well suited for microwave industry, medical electronics, avionics instrumentation, satellites or other applications where space is at premium.

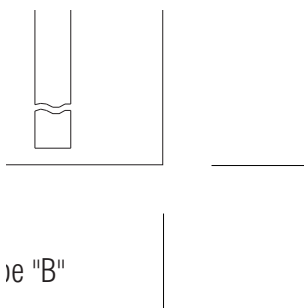
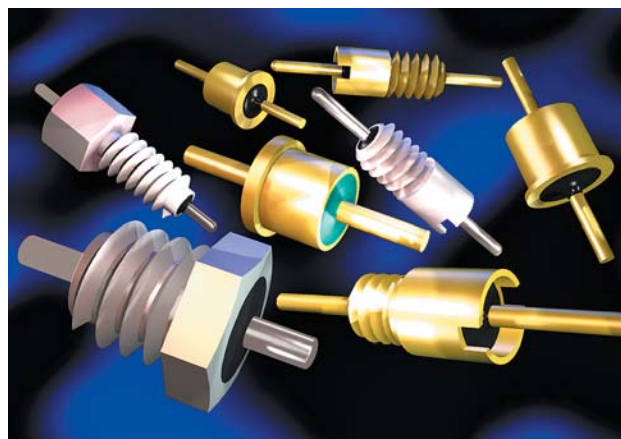

FEATURES

- World's smallest filters, a "must" for avionics and space industry.
- Tiny size for miniaturization of microwave and telecom equipment.
- Hardware real-estate and weight reduction of up to 60%.
- Most complete product offering with solder-in or bolt installation.
- Discoidal capacitor design to meet cost/reliability goals.

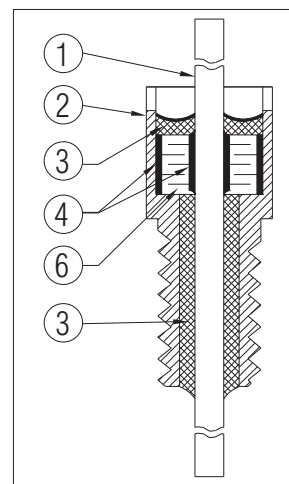

- | | | |
|------------|----------------|---------------|
| ① - LEAD | ② - CASE | ③ - EPOXY |
| ④ - SOLDER | ⑤ - GLASS SEAL | ⑥ - CAPACITOR |

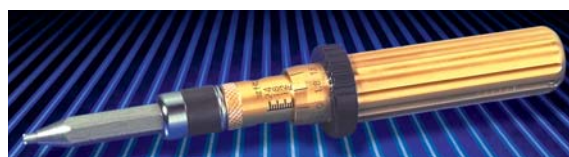

NOTE: Torque limiting tool with custom adapter available upon request.

SPECIFICATIONS

Mechanical

Material: Solder-In: Case and Leads:
Kovar per ASTM F-15
Screw-in: Case: CRS per ASTM-108
Leads: Copper clad steel
(1-64 & 2-56 Thd.)
Copper (4-40 & 8-36 Thd.)

Finish: Solder-in: Gold per Mil-G-45204
Screw-in: Gold per Mil-G-45204 (standard)
Silver optional (1-64 & 2-56 Thd.)
Silver per QQ-S-365 (standard)
Gold optional (4-40 & 8-36 Thd.)

Electrical

Capacitance: measured @ 1KHz and .1 to 1 VRMS, 25°C
Dissipation factor: 3% max.
Insulation resistance: 10,000 Mohms min. @ 25°C, WVDC;
1000 Mohms min. @ 125°C, WVDC
DC resistance: .02 ohm max.
Dielectric withstanding voltage: 200% of WVDC min.

EMI Filters



Miniature, Subminiature & Microminiature

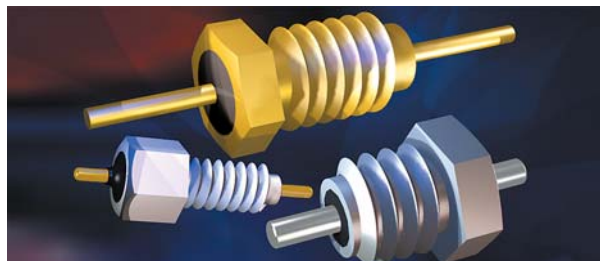

SCREW-IN STYLE, C TYPE ⁴⁻⁴⁰/₈₋₃₆ THD.

SPECIFICATIONS

AVX Part Number	Voltage Vdc (V)	Min. Cap (pF)	Current Idc (A)	MINIMUM NO LOAD INSERTION LOSS (db) @ 25°C PER MIL-STD-220					
				1 MHZ	10 MHZ	100 MHZ	300 MHZ	1 GHZ	10 GHZ
SA1C3-503	50	50000	10	15	35	45	55	70	70
SA1A3-273	100	27000	10	10	30	43	53	65	70
SA1A3-103	100	10000	10	4	20	37	47	60	65
SA1B3-502	200	5000	10	-	15	35	45	55	60
SA1B3-272	200	2700	10	-	10	30	38	50	60
SA1B3-152	200	1500	10	-	5	25	33	45	55
SA1B3-102	200	1000	10	-	4	22	30	42	55
SA1B3-501	200	500	10	-	-	15	25	35	50
SA1B3-251	200	250	10	-	-	10	17	27	40
SA1B3-101	200	100	10	-	-	3	10	20	30
SA1B3-500	200	50	10	-	-	1	6	15	25
SA1B3-250	200	25	10	-	-	-	1	10	22
SA1B3-100	200	10	10	-	-	-	-	3	20
SA1B3-5R0	200	5	10	-	-	-	-	-	15

SA1C1-104	50	100000	10	20	40	50	60	70	70
SA1A1-503	100	50000	10	15	35	45	55	70	70
SA1A1-273	100	27000	10	10	30	43	53	65	70
SA1B1-103	200	10000	10	4	20	37	47	60	65
SA1B1-502	200	5000	10	-	15	35	45	55	60
SA1B1-272	200	2700	10	-	10	30	38	50	60
SA1B1-102	200	1000	10	-	4	22	30	42	55
SA1B1-501	200	500	10	-	-	15	25	35	50
SA1B1-251	200	250	10	-	-	10	17	27	40
SA1B1-101	200	100	10	-	-	3	10	20	30
SA1B1-500	200	50	10	-	-	1	6	15	25
SA1B1-250	200	25	10	-	-	-	1	10	22
SA1B1-100	200	10	10	-	-	-	-	3	20
SA1B1-5R0	200	5	10	-	-	-	-	-	15

SZ1C1-503	50	50000	10	15	35	45	55	70	70
SZ1A1-273	100	27000	10	10	30	43	53	65	70
SZ1A1-103	100	10000	10	4	20	37	47	60	65
SZ1B1-502	200	5000	10	-	15	35	45	55	60
SZ1B1-272	200	2700	10	-	10	30	38	50	60
SZ1B1-152	200	1500	10	-	5	25	33	45	55
SZ1B1-102	200	1000	10	-	4	22	30	42	55
SZ1B1-501	200	500	10	-	-	15	25	35	50
SZ1B1-251	200	250	10	-	-	10	17	27	40
SZ1B1-101	200	100	10	-	-	3	10	20	30
SZ1B1-500	200	50	10	-	-	1	6	15	25
SZ1B1-250	200	25	10	-	-	-	1	10	22
SZ1B1-100	200	10	10	-	-	-	-	3	20
SZ1B1-5R0	200	5	10	-	-	-	-	-	15

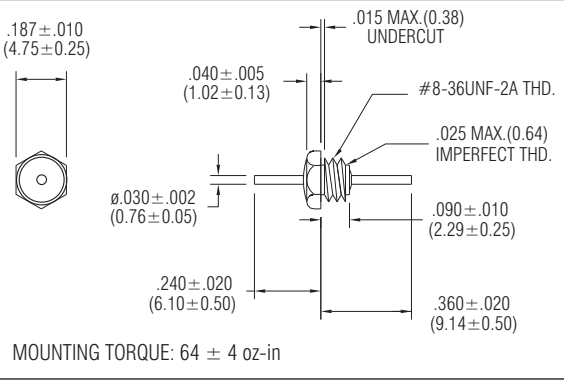
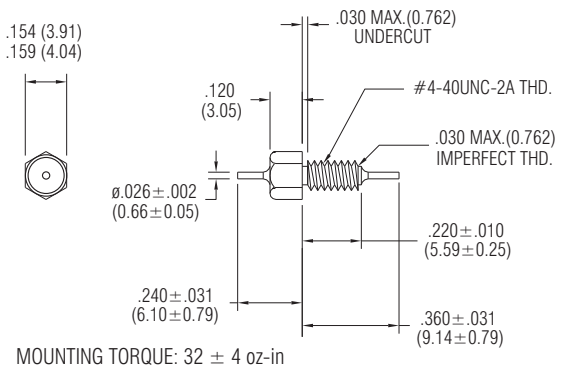
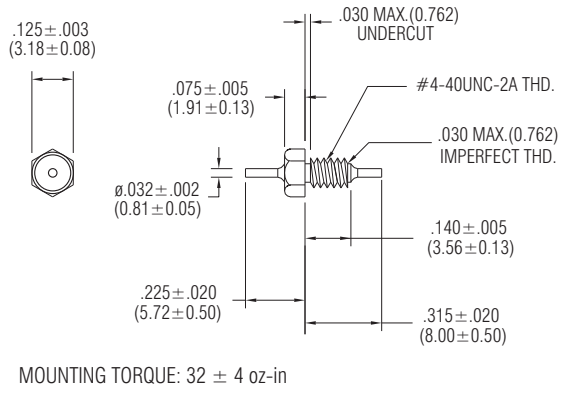

NOTE: Dimensions in inches (millimeters).

Leads

- Custom lead lengths and materials available
- Chamfered or rounded lead tips for mating with connectors

CONFIGURATION OPTIONS

Schematic

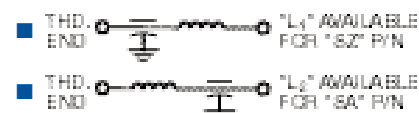

Cylindrical Style EMI Filters

BL Series – .375 Dia. – Button Epoxy Sealed – Circuits Available – C & L

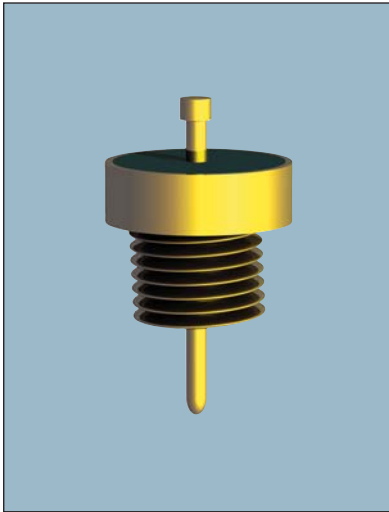

APPLICATIONS

The BL series offers effective filtering from 30 KHz up through 1 GHz. It offers epoxy resin seals on both ends in order to optimize volumetric efficiency and reduce cost. Where severe moisture environments exist the slightly larger companion BK series is recommended as it incorporates a glass to metal hermetic seal at both ends. The BL series is designed for bulk-head mounting in a slotted hole with nut and lockwasher supplied. This series is ideal for low to medium impedance

circuits where large amounts of capacitance to ground can be tolerated. In the “L” section version an internal ferrite bead element provides both inductance and series resistance (lossy characteristic) which improves insertion loss at lower current ratings and provides superior transient performance.

Alternate lead configurations or special capacitance values may be ordered.

Custom packages or filter arrays utilizing the BL series can be furnished.

CHARACTERISTICS

- Internal ferrite bead provides inductance for the L-section version.

- High DC current rating: 15 Amps.

SPECIFICATIONS

- Case/Terminal Plating:
Electro-tin standard – Gold or silver available
- Material:
Case: Brass Standard – Steel available
End Seal: Epoxy
Terminals: Copper nailhead standard
- Operating Temperature Range:
-55°C to +125°C
- Electrical Characteristics:
 - Rated Voltage: See chart
 - Insulation Resistance:
At 25°C: 1,000 megohm-microfarad min., or 50,000 megohms min., whichever is less, at the rated DC voltage
At 125°C: 100 megohm-microfarad min., or 5,000 megohms min., whichever is less
 - Dielectric Withstanding Voltage (DWV):
R-level designs:
2.0 times rated DC voltage
Class B designs:
2.5 times rated DC voltage
 - Capacitance: Values listed in chart are “guaranteed minimum value” (GMV)
- Marking:
Standard Marking: AVX, AVX part number, lot code
BL2 only: Letter “L” denotes ferrite bead inductor at threaded end
See Reliability Codes section for definition of Reliability Level marking. See How to Order section for part number construction.
- Installation:
 - Mounting Torque:
44 oz-in. ± 4 oz-in.
 - Refer to “Installation, Handling, Hardware Options” section of the catalog.

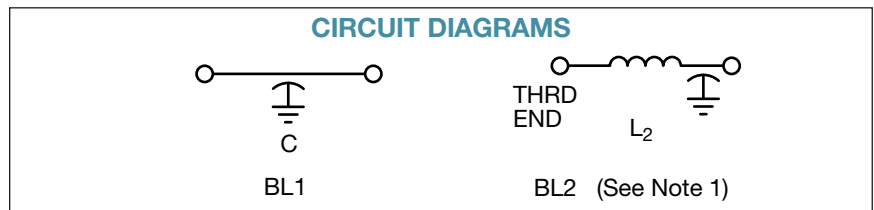
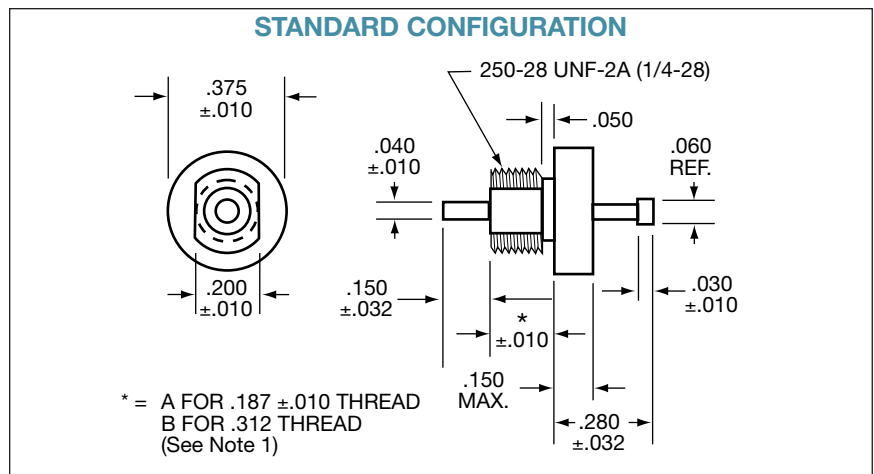

millimeters (inches)

.25 (.010)	2.54 (.100)
.76 (.030)	3.81 (.150)
.81 (.032)	4.57 (.180)
1.02 (.040)	5.08 (.200)
1.52 (.060)	9.53 (.375)

(See Note 2)

Notes:

1. All BL2 L-Section Filters have inductor (bead) at threaded end.
2. Metric equivalent dimensions given for information only.

Cylindrical Style EMI Filters

BL Series – .375 Dia. – Button Epoxy Sealed – Circuits Available – C & L



SPECIFICATIONS

AVX P/N	CKT	CAP (μ F)	DC Voltage	Insertion Loss ¹ Per MIL-STD-220, +25°C						
				30 KHz	150 KHz	300 KHz	1 MHz	10 MHz	100 MHz	1 GHz
BL1CA-754	C	0.750	50	11	24	30	40	40	64	70
BL1CA-105	C	1.000	50	12	24	30	40	40	65	70
BL1CA-125	C	1.200	50	15	28	33	40	40	70	70
BL1CA-145	C	1.400	50	15	28	33	40	40	70	70
BL2CA-754	L2	0.750	50	11	24	30	40	40	64	70
BL2CA-105	L2	1.000	50	12	24	30	40	40	65	70
BL2CA-125	L2	1.200	50	15	28	33	40	40	70	70
BL2CA-145	L2	1.400	50	15	28	33	40	40	70	70
BL1AA-504	C	0.500	100	6	19	25	36	40	60	70
BL1AA-754	C	0.750	100	11	24	30	40	40	64	70
BL1AA-105	C	1.000	100	12	24	30	40	40	65	70
BL1AA-125	C	1.200	100	15	28	33	40	40	70	70
BL2AA-504	L2	0.500	100	6	19	25	36	40	60	70
BL2AA-754	L2	0.750	100	11	24	30	40	40	64	70
BL2AA-105	L2	1.000	100	12	24	30	40	40	65	70
BL2AA-125	L2	1.200	100	15	28	33	40	40	70	70
BL1BA-103	C	0.010	200	–	–	–	2	20	40	55
BL1LA-753	C	0.075	200*	–	–	7	18	37	46	70
BL1LA-154	C	0.150	200*	–	10	16	26	40	52	70
BL2BA-103	L2	0.010	200	–	–	–	2	20	40	55
BL2LA-753	L2	0.075	200*	–	–	7	18	37	51	70
BL2LA-154	L2	0.150	200*	–	10	16	26	40	52	70

* Also rated 125 VAC/400 Hz

¹ Insertion loss limits are based on theoretical values.
Actual measurements may vary due to internal capacitor resonances and other design constraints.

Cylindrical Style EMI Filters

BK Series – .375/.410 Dia. – Button Hermetically Sealed

Circuits Available – C & L



APPLICATIONS

The BK series offers effective filtering from 500 KHz to 10 GHz. Glass sealed for hermeticity, this low profile series is impervious to high moisture, solvents, or other severe environmental conditions commonly encountered in military applications. It is designed for bulkhead mounting in a slotted hole with nut and lockwasher supplied. This series is ideal for low to medium impedance circuits where large amounts of capacitance to

ground can be tolerated. In the “L” section version an internal ferrite bead element provides both inductance and series resistance (lossy characteristic) which improves insertion loss and provides superior transient performance.

Alternate lead configurations or special capacitance values may be ordered.

Custom packages or filter arrays utilizing the BK series can be furnished.

CHARACTERISTICS

- .410 Dia. version (AK) meets or exceeds the applicable requirements of MIL-F-28861/1. See QPL listings.
- Glass hermetic seal on both ends.
- Internal ferrite bead provides inductance for the L-section version.
- High DC current rating: 15 Amps

SPECIFICATIONS

- Case/Terminal Plating:
Electro-tin standard – Silver or gold available
- Material:
Case: Brass standard – Steel available
End Seal: Mild steel
Terminals: Nickel-iron alloy
- Operating Temperature Range:
-55°C to +125°C
- Electrical Characteristics:
 - Rated Voltage: See chart
 - Insulation Resistance:
At 25°C: 1,000 megohm-microfarad min., or 50,000 megohms, whichever is less, at the rated DC voltage
At 125°C: 100 megohm-microfarad min., or 5,000 megohms, whichever is less
 - Dielectric Withstanding Voltage (DWV):
R-level designs:
2.0 times rated DC voltage
Class B, Class S designs:
2.5 times rated DC voltage
 - Capacitance: Values listed in chart are “guaranteed minimum value” (GMV)
- Marking:
Standard Marking: AVX, AVX part number, lot code
BK2 only: Letter “L” denotes ferrite bead inductor at threaded end
See Reliability Codes section for definition of Reliability Level marking. See How to Order section for part number construction.
- Installation:
 - Mounting Torque:
44 oz-in. ± 4 oz-in.
 - Refer to “Installation, Handling, Hardware Options” section of the catalog.

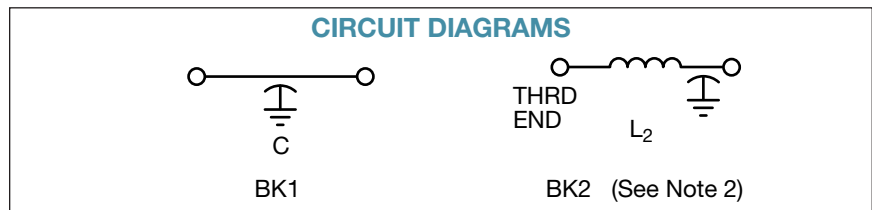
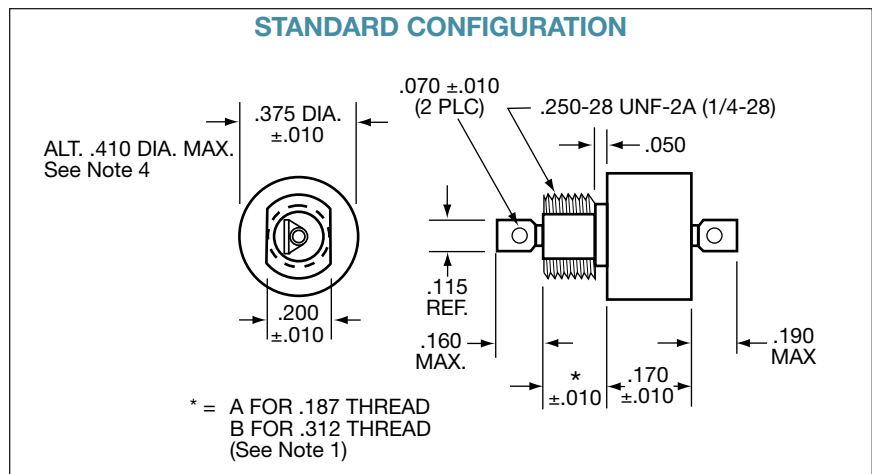

millimeters (inches)

.25 (.010)	4.75 (.187)
1.27 (.050)	4.83 (.190)
1.78 (.070)	5.08 (.200)
2.92 (.115)	7.93 (.312)
3.81 (.150)	9.53 (.375)
4.32 (.170)	—

(See Note 3)
(See Note 1)

Notes:

1. Thread length option. Standard part numbers shown (e.g., BK1CA-103) are .187" thread length. Optional .312 length available. (e.g., BK1CB-103).
2. Ferrite bead inductor at threaded end (BK2 only).
3. Metric equivalent dimensions given for information only.
4. .410 Dia. (identified as AK) is required for all hi-rel tested parts (e.g., MIL-F-28861/1 series).

Cylindrical Style EMI Filters

BK Series – .375/.410 Dia. – Button Hermetically Sealed
Circuits Available – C & L



SPECIFICATIONS

AVX P/N	CKT	CAP (μ F)	DC Voltage	Insertion Loss ¹ Per MIL-STD-220, +25°C						
				30 KHz	150 KHz	300 KHz	1 MHz	10 MHz	100 MHz	1 GHz
BK1CA-125	C	1.200	50	15	28	33	40	40	70	70
BK1CB-125	C	1.200	50	15	28	33	40	40	70	70
BK2CA-125	L2	1.200	50	15	28	33	40	40	70	70
BK2CB-125	L2	1.200	50	15	28	33	40	40	70	70
BK1NA-704	C	0.700	70	10	24	30	40	40	64	70
BK1NB-704	C	0.700	70	10	24	30	40	40	64	70
BK2NA-704	L2	0.700	70	10	24	30	40	40	64	70
BK2NB-704	L2	0.700	70	10	24	30	40	40	64	70
BK1AA-103	C	0.010	100	–	–	–	2	20	40	55
BK1AA-454	C	0.450	100	6	19	25	36	40	60	70
BK1AB-454	C	0.450	100	6	19	25	36	40	60	70
BK1AA-754	C	0.750	100	11	24	30	40	40	64	70
BK1AA-105	C	1.000	100	12	24	30	40	40	65	70
BK2AA-454	L2	0.450	100	6	19	25	36	40	60	70
BK2AB-454	L2	0.450	100	6	19	25	36	40	60	70
BK2AA-754	L2	0.750	100	11	24	30	40	40	64	70
BK2AA-105	L2	1.000	100	12	24	30	40	40	65	70
BK1HA-254	C	0.250	150	–	14	20	31	40	56	70
BK1HB-254	C	0.250	150	–	14	20	31	40	56	70
BK2HA-254	L2	0.250	150	–	14	20	31	40	56	70
BK2HB-254	L2	0.250	150	–	14	20	31	40	56	70
BK1LA-753	C	0.075	200*	–	–	7	18	37	46	70
BK1LA-154	C	0.150	200*	–	10	16	26	40	52	70
BK1LB-154	C	0.150	200*	–	10	16	26	40	52	70
BK2BA-203	L2	0.020	200*	–	–	–	7	25	40	60
BK2LA-753	L2	0.075	200*	–	–	7	18	37	51	70
BK2LA-154	L2	0.150	200*	–	10	16	26	40	52	70
BK2LB-154	L2	0.150	200*	–	10	16	26	40	52	70

* Also rated 125 VAC/400 Hz

¹ Insertion loss limits are based on theoretical values.
Actual measurements may vary due to internal capacitor resonances and other design constraints.

Cylindrical Style EMI Filters

CK Series – .375 Dia. – Button Hermetically Sealed – Circuits Available – C & L



APPLICATIONS

The CK series offers effective filtering from 100 KHz to 10 GHz. Glass sealed for hermeticity, this medium profile series is impervious to high moisture, solvents, or other severe environmental conditions commonly encountered in military applications. It is designed for bulkhead mounting in a slotted hole with nut and lockwasher supplied. This series is ideal for low to medium impedance circuits where large amounts of capacitance to

ground can be tolerated. In the “L” section version an internal ferrite bead element provides both inductance and series resistance (lossy characteristic) which improves insertion loss and provides superior transient performance.

Alternate lead configurations or special capacitance values may be ordered.

Custom packages or filter arrays utilizing the CK series can be furnished.

CHARACTERISTICS

- Meets or exceeds the applicable requirements of MIL-F-15733, and the environmental/test requirements of MIL-F-28861.
- Glass hermetic seal on both ends.
- Internal ferrite bead provides inductance

for the L-section version.

- High DC current rating: 15 Amps.
- High capacitance values available.
- Conservatively rated for 125 VAC/400 Hz in certain values.

SPECIFICATIONS

- Case/Terminal Plating:
Electro-tin standard – Silver or gold available
- Material:
Case: Brass standard – Steel available
End Seal: Mild steel
Terminals: Nickel-iron alloy
- Operating Temperature Range:
-55°C to +125°C
- Electrical Characteristics:
 - Rated Voltage: See chart
 - Insulation Resistance:
At 25°C: 1,000 megohm-microfarad min., or 50,000 megohms min., whichever is less, at the rated DC voltage
At 125°C: 100 megohm-microfarad min., or 5,000 megohms min., whichever is less
 - Dielectric Withstanding Voltage (DWV):
R-level designs:
2.0 times rated DC voltage
Class B, Class S designs:
2.5 times rated DC voltage
 - Capacitance: Values listed in chart are “guaranteed minimum value” (GMV)
- Marking:
Standard Marking: AVX, AVX part number, rated current, voltage, lot code
B. CK2 only: Letter “L” to denote ferrite bead inductor at threaded end
C. See Reliability Codes section for definition of Reliability Level marking. See How to Order section for part number construction.
- Installation:
 - Mounting Torque: 44 oz-in. ± 4 oz-in.
 - Refer to “Installation, Handling, Hardware Options” section of the catalog.

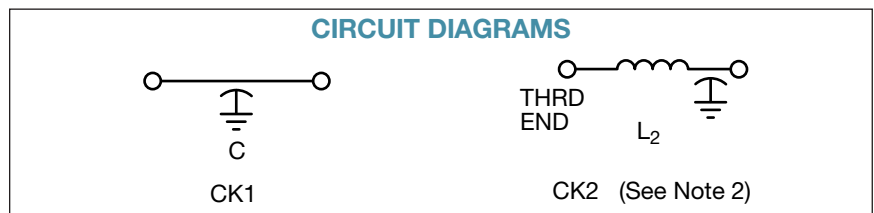
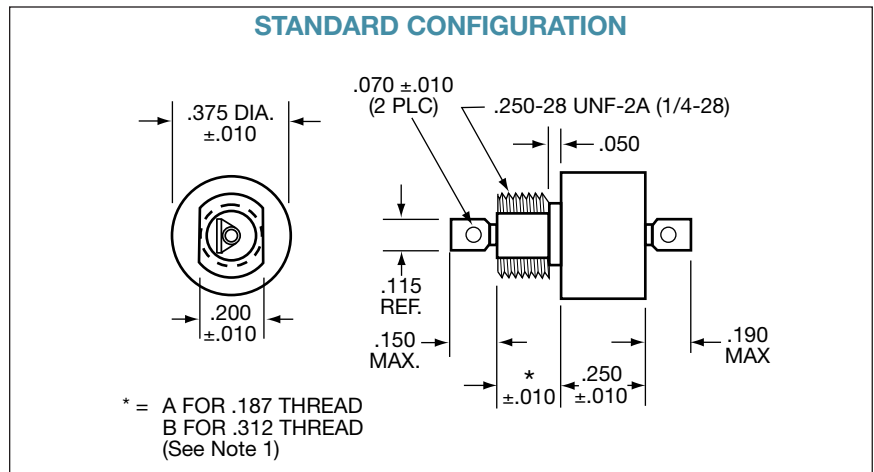

millimeters (inches)

0.25 (.010)	4.83 (.190)
1.27 (.050)	5.08 (.200)
1.78 (.070)	6.35 (.250)
2.92 (.115)	7.93 (.312)
3.81 (.150)	9.53 (.375)
4.75 (.187)	—

(See Note 3)

Notes:

- Thread length option.
EXAMPLE: CK1CA-103 (.187 thrd. L)
CK1CB-103 (.312 thrd. L).
- All CK2 L-Section Filters have inductor (bead) at threaded end.
- Metric equivalent dimensions given for information only.

Cylindrical Style EMI Filters

CK Series – .375 Dia. – Button Hermetically Sealed – Circuits Available – C & L



SPECIFICATIONS

AVX P/N	Current (A)	CKT	CAP (μ F)	DC Voltage	Insertion Loss ¹ Per MIL-STD-220, +25°C						
					30 KHz	150 KHz	500 KHz	1 MHz	10 MHz	100 MHz	1 GHz
CK1CA-754	15	C	0.750	50	11	24	30	40	40	64	70
CK1CA-105	15	C	1.000	50	12	24	30	40	40	65	70
CK1CA-145	15	C	1.400	50	15	28	33	40	40	70	70
CK1CA-205	15	C	2.000	50	16	30	35	43	45	70	70
CK2CA-754	15	L2	0.750	50	11	24	30	40	40	64	70
CK2CA-105	15	L2	1.000	50	12	24	30	40	40	65	70
CK2CA-145	15	L2	1.400	50	15	28	33	40	40	70	70
CK2CA-205	15	L2	2.000	50	16	30	35	43	45	70	70
CK1AA-504	15	C	0.500	100	–	16	26	34	42	58	70
CK1AA-754	15	C	0.750	100	11	24	30	40	40	64	70
CK1AA-105	15	C	1.000	100	12	24	30	40	40	65	70
CK1AA-185	15	C	1.800	100	15	28	33	41	45	70	70
CK2AA-504	15	L2	0.500	100	–	16	26	36	44	60	70
CK2AA-754	15	L2	0.750	100	11	24	30	40	40	64	70
CK2AA-105	15	L2	1.000	100	12	24	30	40	40	65	70
CK2AA-185	15	L2	1.800	100	15	28	33	41	45	70	70
CK1BA-103	15	C	0.010	200	–	–	–	2	20	40	55
CK1LA-753	15	C	0.075	200*	–	–	7	18	37	46	70
CK1BA-104	15	C	0.100	200	–	–	14	24	38	50	70
CK1LA-154	15	C	0.150	200*	–	10	16	26	40	52	70
CK1BA-304	15	C	0.300	200	–	15	23	32	40	56	70
CK1BA-504	15	C	0.500	200	6	19	25	36	40	58	70
CK2BA-103	15	L2	0.010	200	–	–	–	2	20	40	55
CK2LA-753	15	L2	0.075	200*	–	–	7	18	37	51	70
CK2BA-104	15	L2	0.100	200	–	–	14	24	38	50	70
CK2LA-154	15	L2	0.150	200*	–	10	16	26	40	52	70
CK2BA-304	15	L2	0.300	200	–	15	23	32	40	56	70
CK2BA-504	15	L2	0.500	200	6	19	25	36	40	60	70

* Also rated 125 VAC/400 Hz

¹ Insertion loss limits are based on theoretical values.
Actual measurements may vary due to internal capacitor resonances and other design constraints.

Cylindrical Style EMI Filters

GK Series – .375/.410 Dia.

Hermetically Sealed – Circuits Available – C, L, π , T



APPLICATIONS

The GK series offers effective filtering from 30 KHz to 10 GHz. Glass sealed for hermeticity, this series is impervious to high moisture, solvents, or other severe environmental conditions commonly encountered in military applications. It is designed for bulkhead mounting in a slotted hole with nut and lockwasher supplied.

The “L” and “T” configurations are designed to provide effective attenuation over a wide range of circuit impedances. For current ratings under 10 Amps toroidal wound

inductor elements offer increased filter performance and protection against circuit transients. Data showing the actual inductance versus various levels of DC or AC bias current are available as well as the attenuation in any combination of source and load impedances.

Alternate lead configurations or special capacitance/inductance values may be ordered.

Custom packages or filter arrays utilizing the GK series can be furnished.

CHARACTERISTICS

- .410 Dia. version (HK) meets or exceeds the applicable requirements of MIL-F-28861/2,/3,/4,/5. See QPL listing.
- Glass hermetic seal on both ends.
- Wound toroidal inductor used in current ratings up through 5 Amps. Ferrite bead inductor used in 10 and 15 Amp designs.
- High DC current rating: 15 Amps.
- High capacitance values available.

SPECIFICATIONS

- | | | |
|---|--|---|
| <p>1. Case/Terminal Plating:
Electro-tin standard –
Silver or gold available</p> <p>2. Material:
Case: Brass standard – Steel available
End Seal: Mild steel
Terminals: Nickel-iron alloy</p> <p>3. Operating Temperature Range:
-55°C to +125°C</p> <p>4. Electrical Characteristics:
A. Rated Voltage and Current: See chart
B. Insulation Resistance:
At 25°C: 1,000 megohm-microfarad min., or 50,000 megohms min., whichever is less, at the rated DC voltage
At 125°C: 100 megohm-microfarad min., or 5,000 megohms min., whichever is less</p> | <p>C. Dielectric Withstanding Voltage (DWV):
R-level designs:
2.0 times rated DC voltage
Class B, Class S designs:
2.5 times rated DC voltage</p> <p>D. Capacitance: Total capacitance listed in chart for each filter type is “guaranteed minimum value” (GMV)</p> <p>5. Marking:
Standard Marking: AVX, AVX part number, rated current, voltage, lot code, schematic
NOTE: Schematic to indicate location of inductor (standard or reverse) for GK2 L-Section Filters.</p> | <p>See Reliability Codes section for definition of Reliability Level marking. See How to Order section for part number construction.</p> <p>6. Installation:
A. Mounting Torque: 44 oz-in. \pm 4 oz-in.
B. Refer to “Installation, Handling, Hardware Options” section of the catalog.</p> |
|---|--|---|

Cylindrical Style EMI Filters

GK Series – .375/.410 Dia.

Hermetically Sealed – Circuits Available – C, L, π , T



STANDARD CONFIGURATION

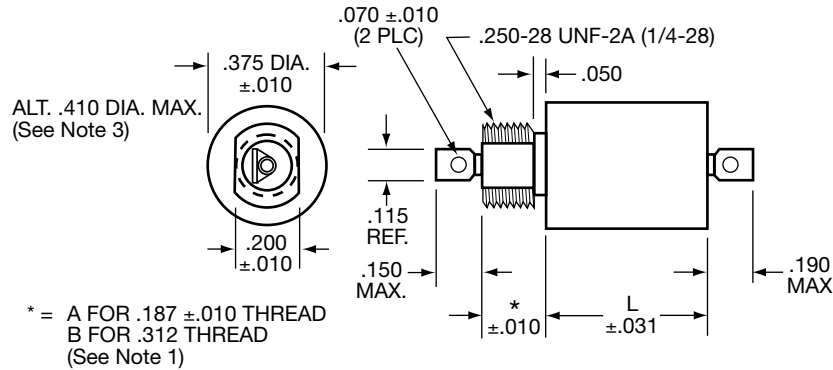

CIRCUIT DIAGRAMS

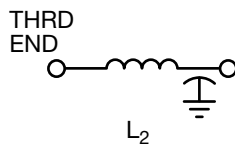

GK2 - Standard

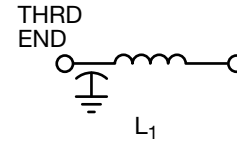

GK2 - Reverse

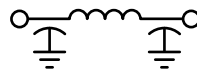

GK3

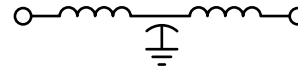

GK4

millimeters (inches)

0.25 (.010)	4.75 (.187)
0.79 (.031)	4.83 (.190)
1.27 (.050)	5.08 (.200)
1.78 (.070)	7.93 (.312)
2.92 (.115)	9.53 (.375)
3.81 (.150)	13.72 (.540)

(See Note 2)

Notes:

1. Thread length option. Standard part numbers shown (e.g., GK2BA-S02) are .187" thread length. Optional .312 length available (e.g., GK2BB-S02).
2. Metric equivalent dimensions given for information only.

3. All QPL MIL-F-28861, and Hi-rel, will be supplied with .410 diameter (HK). See applicable slash sheet for mechanical dimensions.

* = A for .187 ±.010 Thread
 B for .312 Thread
 (See Note 1)

Cylindrical Style EMI Filters

GK Series – .375/.410 Dia. – Hermetically Sealed – Circuits Available – L, π , T



SPECIFICATIONS

AVX P/N	Current (A)	CKT	L. dim	DCR (Ω)	Insertion Loss ¹ Per MIL-STD-220, +25°C							
					10 KHz	30 KHz	150 KHz	300 KHz	1 MHz	10 MHz	100 MHz	1 GHz
50 VDC, 1.4 μF												
GK2CA-S01	0.06	L2	0.540	12.00	16	44	70	70	70	70	70	70
GK2CA-S02	0.10	L2	0.540	10.00	15	34	62	70	70	70	70	70
GK2CA-S03	0.15	L2	0.540	4.000	7	24	52	64	70	70	70	70
GK2CA-S04	0.25	L2	0.540	4.000	6	25	53	65	70	70	70	70
GK2CA-S05	0.30	L2	0.540	0.500	5	16	35	45	66	70	70	70
GK2CA-S06	0.45	L2	0.540	0.300	5	15	33	44	65	70	70	70
GK2CA-S07	0.50	L2	0.540	1.000	5	16	41	54	70	70	70	70
GK2CA-S08	1.00	L2	0.540	0.250	5	15	31	42	63	70	70	70
GK2CA-S09	2.00	L2	0.540	0.063	5	15	28	35	51	70	70	70
GK2CA-S10	3.00	L2	0.540	0.027	5	15	28	34	45	70	70	70
GK2CA-S12	10.0	L2	0.540	0.008	5	15	28	34	44	52	65	65
GK3CA-P02	0.10	π	0.540	10.00	12	44	70	70	70	70	70	70
GK3CA-P04	0.25	π	0.540	4.000	8	36	70	70	70	70	70	70
GK3CA-P07	0.50	π	0.540	1.000	7	24	66	70	70	70	70	70
GK3CA-P08	1.00	π	0.540	0.250	5	15	54	70	70	70	70	70
GK3CA-P09	2.00	π	0.540	0.063	5	15	40	60	70	70	70	70
GK3CA-P10	3.00	π	0.540	0.027	5	15	30	50	70	70	70	70
GK3CA-P12	10.0	π	0.540	0.008	5	15	28	34	40	52	70	70
GK4CA-T08	1.00	T	1.020	0.500	5	16	34	56	70	70	70	70
GK4CA-T09	2.00	T	1.020	0.090	5	15	26	37	61	70	70	70
GK4CA-T16	4.00	T	1.020	0.030	5	15	26	34	47	70	70	70
GK4CA-T12	10.0	T	1.020	0.008	5	17	27	34	44	60	70	70

¹ Insertion loss limits are based on theoretical values. Actual measurements may vary due to internal capacitor resonances and other design constraints.

NOTE: All "L2" circuits are also available as "L1". Insertion loss and other parameters are identical. Only the part number changes (e.g., L2 = GK2LA-S04, L1 = GK2LA-R04).

Cylindrical Style EMI Filters

GK Series – .375/.410 Dia. – Hermetically Sealed –

Circuits Available – L, π , T



SPECIFICATIONS

AVX P/N	Current (A)	CKT	L. dim	CAP (μ F)	DCR (Ω)	Insertion Loss ¹ Per MIL-STD-220, +25°C									
						15 KHz	30 KHz	50 KHz	100 KHz	150 KHz	300 KHz	1 MHz	10 MHz	100 MHz	1 GHz
70 VDC, .7–1.4 μF															
GK2NA-S02	0.10	L2	0.540	0.700	1.700	9	20	29	41	48	60	70	70	70	70
GK2NA-S05	0.30	L2	0.540	0.700	0.770	6	15	23	35	42	54	70	70	70	70
GK2NA-S07	0.50	L2	0.540	0.700	0.360	5	12	19	29	36	48	69	70	70	70
GK2NA-S08	1.00	L2	0.540	0.700	0.140	5	11	15	21	26	36	55	70	70	70
GK2NA-S10	3.00	L2	0.540	0.700	0.050	5	10	14	20	24	31	45	70	70	70
GK2NA-S11	5.00	L2	0.540	0.700	0.015	–	–	–	14	17	24	36	60	70	70
GK2NA-S12	10.0	L2	0.540	0.700	0.008	–	10	14	20	24	30	40	40	64	70
GK3NA-P02	0.10	π	0.540	1.400	1.700	15	36	50	69	79	80	80	80	80	80
GK3NA-P05	0.30	π	0.540	1.400	0.770	–	29	44	62	73	80	80	80	80	80
GK3NA-P07	0.50	π	0.540	1.400	0.360	–	21	37	56	67	80	80	80	80	80
GK3NA-P08	1.00	π	0.540	1.400	0.140	–	–	20	46	57	75	80	80	80	80
GK3NA-P10	3.00	π	0.540	1.400	0.050	–	–	–	17	36	51	80	80	80	80
GK3NA-P11	5.00	π	0.540	1.400	0.015	–	–	–	–	16	38	75	80	80	80
GK3NA-P12	10.0	π	0.540	1.400	0.008	5	15	20	24	28	34	40	52	80	80
GK4NA-T08	1.00	T	1.020	0.750	–	–	10	15	21	26	49	70	70	70	70
GK4NA-T09	2.00	T	1.020	0.750	–	–	10	13	17	20	32	55	70	70	70
GK4NA-T16	4.00	T	1.020	0.750	–	–	9	12	15	19	29	42	70	70	70
GK4NA-T12	10.0	T	1.020	0.750	–	–	9	12	15	19	28	38	55	70	70

¹ Insertion loss limits are based on theoretical values.
Actual measurements may vary due to internal capacitor resonances and other design constraints.

NOTE: All “L2” circuits are also available as “L1”.
Insertion loss and other parameters are identical.
Only the part number changes
(e.g., L2 = GK2LA-S04, L1 = GK2LA-R04).

Cylindrical Style EMI Filters

GK Series – .375/.410 Dia. – Hermetically Sealed –

Circuits Available – L, π



SPECIFICATIONS

AVX P/N	Current (A)	CKT	L. dim	CAP (μ F)	DCR (Ω)	Insertion Loss ¹ Per MIL-STD-220, +25°C							
						10 KHz	30 KHz	150 KHz	300 KHz	1 MHz	10 MHz	100 MHz	1 GHz
100 VDC, .45–1.4 μF													
GK2AA-S01	0.06	L2	0.540	1.40	12.00	15	44	70	70	70	70	70	70
GK2AA-S02	0.10	L2	0.540	1.40	10.00	12	34	62	70	70	70	70	70
GK2AA-S03	0.15	L2	0.540	1.40	4.000	7	24	52	64	70	70	70	70
GK2AA-S05	0.30	L2	0.540	1.40	0.500	–	14	35	45	66	70	70	70
GK2AA-S06	0.45	L2	0.540	1.40	0.300	–	14	33	44	65	70	70	70
GK2AA-S07	0.50	L2	0.540	1.40	1.000	–	16	41	54	70	70	70	70
GK2AA-S09	2.00	L2	0.540	1.40	0.063	–	15	28	35	51	70	70	70
GK2AA-S12	10	L2	0.540	1.40	0.008	–	14	28	33	44	52	70	70
GK3AA-P02	0.10	π	0.540	1.00	10.00	12	40	70	70	70	70	70	70
GK3AA-P07	0.50	π	0.540	1.00	1.000	–	18	60	70	70	70	70	70
GK3AA-P09	2.00	π	0.540	1.00	0.063	–	9	36	53	70	70	70	70
GK3AA-P12	10.0	π	1.020	1.00	0.008	–	9	24	29	40	70	70	70
GK4AA-T08	1.00	T	1.020	0.75	0.500	–	10	25	49	70	70	70	70
GK4AA-T09	2.00	T	1.020	0.75	0.090	–	10	20	32	56	70	70	70
GK4AA-T16	4.00	T	1.020	0.75	0.030	–	10	19	29	42	70	70	70
GK4AA-T12	10.0	T	1.020	0.75	0.008	–	9	19	28	39	58	65	65
GK2AA-S04	0.25	L2	0.540	0.45	1.500	–	–	38	50	60	60	60	60
GK3AA-P04	0.25	π	0.540	0.90	1.500	–	–	64	80	80	80	80	80
GK2AA-S08	1.00	L2	0.540	0.45	0.250	–	–	23	34	55	60	60	60
GK3AA-P08	1.00	π	0.540	0.90	0.250	–	–	52	70	80	80	80	80
GK2AA-S10	3.00	L2	0.540	0.45	0.050	–	–	18	27	45	60	60	60
GK3AA-P10	3.00	π	0.540	0.90	0.050	–	–	25	51	80	80	80	80
GK2AA-S11	5.00	L2	0.540	0.45	0.015	–	–	17	24	36	60	60	60
GK3AA-P11	5.00	π	0.540	0.90	0.015	–	–	–	38	75	80	80	80

¹ Insertion loss limits are based on theoretical values.
Actual measurements may vary due to internal capacitor resonances and other design constraints.

NOTE: All “L2” circuits are also available as “L1”.
Insertion loss and other parameters are identical.
Only the part number changes
(e.g., L2 = GK2LA-S04, L1 = GK2LA-R04).

Cylindrical Style EMI Filters

GK Series – .375/.410 Dia. – Hermetically Sealed –

Circuits Available – L, π , T



SPECIFICATIONS

AVX P/N	Current (A)	CKT	L. dim	CAP (μ F)	DCR (Ω)	Insertion Loss ¹ Per MIL-STD-220, +25°C							
						100 KHz	150 KHz	300 KHz	1 MHz	10 MHz	100 MHz	1 GHz	
150 VDC, .25–.50 μF													
GK2HA-S02	0.10	L2	0.540	0.250	1.700	32	39	51	60	60	60	70	
GK2HA-S05	0.30	L2	0.540	0.250	0.770	25	30	44	60	60	60	70	
GK2HA-S07	0.50	L2	0.540	0.250	36.00	20	26	39	59	60	60	70	
GK2HA-S08	1.00	L2	0.540	0.250	14.00	12	16	26	48	60	60	70	
GK2HA-S10	3.00	L2	0.540	0.250	0.050	11	15	20	36	60	60	70	
GK2HA-S11	5.00	L2	0.540	0.250	0.015	8	12	20	32	60	60	70	
GK2HA-S12	10.0	L2	0.540	0.250	0.008	6	12	20	32	40	56	70	
GK3HA-P02	0.10	π	0.540	0.500	1.700	49	60	70	80	80	80	80	
GK3HA-P05	0.30	π	0.540	0.500	0.770	43	53	70	80	80	80	80	
GK3HA-P07	0.50	π	0.540	0.500	0.360	37	48	66	80	80	80	80	
GK3HA-P08	1.00	π	0.540	0.500	0.140	28	40	58	80	80	80	80	
GK3HA-P10	3.00	π	0.540	0.500	0.050	–	–	38	70	80	80	80	
GK3HA-P11	5.00	π	0.540	0.500	0.015	–	–	20	63	80	80	80	
GK3HA-P12	10.0	π	0.540	0.500	0.008	–	–	15	35	60	80	80	
GK4HA-T08	1.00	T	1.020	0.250	0.500	15	23	42	70	80	80	80	
GK4HA-T09	2.00	T	1.020	0.250	0.090	9	13	32	50	70	80	80	
GK4HA-T16	4.00	T	1.020	0.250	0.030	6	10	21	40	60	80	80	
GK4HA-T12	10.0	T	1.020	0.250	0.006	–	9	21	28	44	60	80	
200 VDC, .15–.36 μF													
AVX P/N	Current (A)	CKT	L. dim	CAP (μ F)	DCR (Ω)	10 KHz	30 KHz	150 KHz	300 KHz	1 MHz	10 MHz	100 MHz	1 GHz
GK2BA-S02	0.10	L2	0.540	0.150	10.00	–	21	50	61	70	70	70	70
GK2BA-S04	0.25	L2	0.540	0.150	0.400	–	11	39	51	70	70	70	70
GK2BA-S07	0.50	L2	0.540	0.150	1.000	–	3	29	41	63	70	70	70
GK2BA-S08	1.00	L2	0.540	0.150	0.250	–	–	18	28	49	70	70	70
GK2BA-S09	2.00	L2	0.540	0.150	0.063	–	–	15	21	38	70	70	70
GK2BA-S10	3.00	L2	0.540	0.150	0.027	–	–	15	21	31	70	70	70
GK2BA-S12	10.0	L2	0.540	0.150	0.008	–	–	15	21	31	51	60	60
GK3BA-P02	0.10	π	0.540	0.360	10.00	–	21	61	70	70	70	70	70
GK3BA-P04	0.25	π	0.540	0.360	4.000	–	10	52	68	70	70	70	70
GK3BA-P07	0.50	π	0.540	0.360	1.000	–	–	44	63	70	70	70	70
GK3BA-P08	1.00	π	0.540	0.360	0.250	–	–	30	46	70	70	70	70
GK3BA-P09	2.00	π	0.540	0.360	0.063	–	–	16	33	63	70	70	70
GK3BA-P10	3.00	π	0.540	0.360	0.027	–	–	–	21	55	70	70	70
GK3BA-P12	10.0	π	0.540	0.360	0.008	–	–	–	20	30	60	70	70
GK4BA-T08	1.00	T	1.020	0.150	0.500	–	3	17	42	70	70	70	70
GK4BA-T09	2.00	T	1.020	0.150	0.090	–	–	12	24	48	70	70	70
GK4BA-T16	4.00	T	1.020	0.150	0.030	–	–	12	21	34	70	70	70
GK4BA-T12	10.0	T	1.020	0.150	0.008	–	3	12	21	31	50	60	60

¹ Insertion loss limits are based on theoretical values.
Actual measurements may vary due to internal capacitor resonances and other design constraints.

NOTE: All “L2” circuits are also available as “L1”. Insertion loss and other parameters are identical.
Only the part number changes (e.g., L2 = GK2LA-S04, L1 = GK2LA-R04).

Cylindrical Style EMI Filters

GK Series – .375/.410 Dia. – Hermetically Sealed –

Circuits Available – L, Π , T



SPECIFICATIONS

AVX P/N	Current (A)	CKT	L. dim	CAP (μ F)	DCR (Ω)	Insertion Loss ¹ Per MIL-STD-220, +25°C							
						10 KHz	30 KHz	150 KHz	300 KHz	1 MHz	10 MHz	100 MHz	1 GHz
200 VDC (125 VAC/400 Hz) .15–.30 μF													
GK2LA-S02	0.10	L2	0.540	0.150	10.00	–	14	42	54	70	70	70	70
GK2LA-S07	0.50	L2	0.540	0.150	1.000	–	–	23	35	56	70	70	70
GK2LA-S09	2.00	L2	0.540	0.150	0.063	–	–	8	14	30	70	70	70
GK2LA-S12	10.0	L2	0.540	0.150	0.008	–	–	8	14	25	45	60	60
GK3LA-P02	0.10	Π	0.540	0.300	10.00	–	21	60	70	70	70	70	70
GK3LA-P07	0.50	Π	0.540	0.300	1.000	–	–	40	56	70	70	70	70
GK3LA-P10	3.00	Π	0.540	0.300	0.027	–	–	–	25	54	70	70	70
GK3LA-P12	10.0	Π	0.540	0.300	0.008	–	–	–	20	30	70	70	70
GK2LA-S04	0.25	L2	0.540	0.150	1.500	–	6	28	40	60	60	60	70
GK2LA-S08	1.00	L2	0.540	0.150	0.250	–	–	13	24	45	60	60	70
GK2LA-S10	3.00	L1	0.540	0.150	0.050	–	–	8	16	30	60	60	70
GK2LA-S11	5.00	L2	0.540	0.150	0.015	–	–	8	14	26	55	55	70
GK3LA-P04	0.25	Π	0.540	0.300	1.500	–	8	44	62	80	80	80	80
GK3LA-P08	1.00	Π	0.540	0.300	0.250	–	–	32	50	80	80	80	80
GK3LA-P10	3.00	Π	0.540	0.300	0.050	–	–	–	19	59	80	80	80
GK3LA-P11	5.00	Π	0.540	0.300	0.015	–	–	–	–	51	80	80	80
GK4LA-T08	1.00	T	1.020	0.150	0.500	–	–	10	36	66	70	70	70
GK4LA-T09	2.00	T	1.020	0.150	0.090	–	–	7	18	41	70	70	70
GK4LA-T16	4.00	T	1.020	0.150	0.030	–	–	8	15	27	70	70	70
GK4LA-T12	10.0	T	1.020	0.150	0.008	–	–	8	15	25	70	70	70

¹ Insertion loss limits are based on theoretical values.
Actual measurements may vary due to internal capacitor resonances and other design constraints.

NOTE: All “L2” circuits are also available as “L1”.
Insertion loss and other parameters are identical.
Only the part number changes
(e.g., L2 = GK2LA-S04, L1 = GK2LA-R04).

Cylindrical Style EMI Filters

JD Series – .690 Dia.

Hermetically Sealed – Circuits Available – C, L, π , T

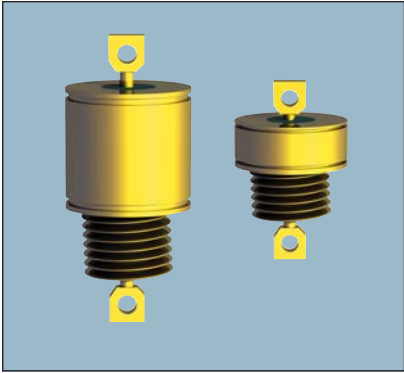

APPLICATIONS

The JD series offers effective filtering from 14 KHz to 10 GHz. The large diameter, increased length, restricted capacitance values and conservative dielectrics of the JD series are particularly important design features for 400 Hz AC applications where high reactive currents and the resultant heat dissipation must be controlled. Glass sealed on both ends for hermeticity, this series is impervious to high moisture, solvents, or other severe environmental conditions commonly encountered in military applications. It is designed for bulkhead mounting in a slotted hole with nut and lockwasher supplied.

The 230 VAC “T” section style is uniquely capable of handling very high pulse inrush currents or overvoltage conditions typical of EMP.

In addition, transient voltage suppression devices can be added to any of the JD circuit designs to provide complete circuit protection against EMP, lightning, or voltage spikes such as MIL-STD-704. These devices when combined with high frequency attenuation characteristics of the discoidal capacitor and toroidal

inductors offer significant performance advantages by suppressing and absorbing the EMP pulse over a very broad spectral range. Very high pulse currents will occur within the EMI filter, however, reradiation to sensitive electronic circuits is prevented by the fully shielded case design. In some cases a slight increase in the case length of the filter is required to provide space for the transient suppression device.

The “L”, and the “T” designs are designed to provide effective attenuation over a wide range of circuit impedances. For current ratings under 15 Amps toroidal wound inductor elements offer increased filter performance and protection against circuit transients. Data showing the actual inductance versus various levels of DC or AC bias current are available as well as the attenuation in any combination of source and load impedance.

Alternate lead configurations or special capacitance/inductance values may be ordered.

Custom packages or filter arrays utilizing the JD series can be furnished.

CHARACTERISTICS

- Designed to meet the requirements of DESC drawings 84083, 84084 and MIL-F-28861/16 and /17.
- Glass hermetic seal on both ends.
- Wound toroidal inductor used in designs up to 10 Amps. 15 Amp designs incorporate ferrite bead inductor.
- Superior heat dissipation for both 125 VAC and 230 VAC designs.

SPECIFICATIONS

1. Case/Terminal Plating:
Electro-tin standard – Silver or gold available
2. Material:
Case: Brass standard – Steel available
End Seal: Mild steel
Terminals: Nickel-iron alloy
3. Operating Temperature Range:
-55°C to +125°C
4. Electrical Characteristics:
 - A. Rated Voltage:
300 VDC/125 VAC, 400 Hz or 400 VDC/230 VAC, 400 Hz
 - B. Current Rating - see chart
 - C. Insulation Resistance:
At 25°C: 1,000 megohm-microfarad min., or 50,000 megohms min., whichever is less, at the rated DC voltage
At 125°C: 100 megohm-microfarad min., or 5,000 megohms min., whichever is less
 - D. Dielectric Withstanding Voltage (DWW):
R-level designs:
2.0 times rated DC voltage
Class B, Class S designs:
2.5 times rated DC voltage
3. Capacitance: Total capacitance listed in chart for each filter type is “guaranteed minimum value” (GMV)
5. Marking:
Standard Marking: AVX, AVX part number, rated voltage, current, lot number, schematic
NOTE: Schematic to indicate location of inductor (standard or reverse) for JD2 L-Section Filters. See Reliability Codes section for definition of Reliability Level marking. See How to Order section for part number construction.
6. Installation:
 - A. Mounting Torque: 60 oz-in. \pm 4 oz-in.
 - B. Refer to “Installation and Handling” section of Filter Design Guide

Cylindrical Style EMI Filters

JD Series – .690 Dia. – Hermetically Sealed –

Circuits Available – C, L, π , T



STANDARD CONFIGURATION

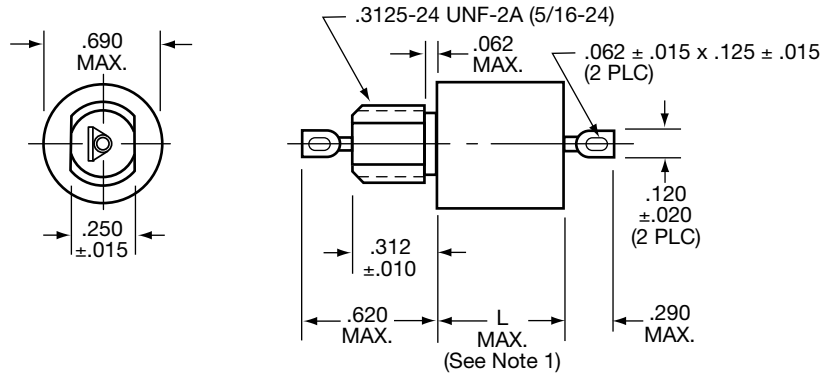

CIRCUIT DIAGRAMS

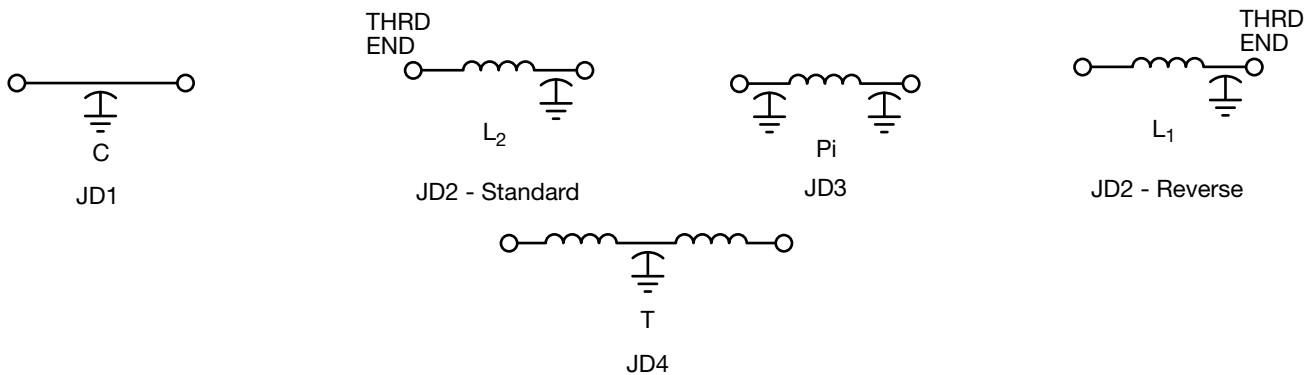

millimeters (inches)

0.08 (.003)	6.35 (.250)
0.13 (.005)	7.37 (.290)
0.18 (.007)	7.92 (.312)
0.25 (.010)	9.53 (.375)
0.38 (.015)	10.67 (.420)
0.51 (.020)	11.18 (.440)
0.56 (.022)	15.75 (.620)
1.14 (.045)	17.27 (.680)
1.57 (.062)	17.78 (.700)
2.36 (.093)	26.92 (1.060)
3.05 (.120)	30.61 (1.205)
3.18 (.125)	33.02 (1.300)

(See Note 2)

MIL-F-28861/17 (See P/N Table)

Dash No.	L Dimension Max.	Weight (grams) Max.
001	.700	18.0
002	1.060	20.0
003	1.060	20.0
004	1.060	20.0
005	1.060	20.0
006	1.060	20.0
007	1.060	20.0
008	1.060	20.0
009	1.060	20.0
010	1.060	20.0
011	1.060	20.0
012	1.205	29.0
013	1.205	29.0
014	1.205	29.0
015	1.205	29.0
016	1.205	29.0
017	1.300	29.0
018	1.300	29.0
019	1.300	29.0

MIL-F-28861/16 (See P/N Table)

Dash No.	L Dimension Max.
001	.700
002 through 011	1.060
012 through 016	1.205
017 through 019	1.300

Notes:

1. Refer to Part Number Table for L-Max for specific filter.
2. Metric equivalent dimensions given for information only.
3. All dimensions for JD series filters established per MIL-F-28861/16 and /17, and DESC 84083 and 84084 requirements.

Cylindrical Style EMI Filters

JD Series – .690 Dia. – Hermetically Sealed – Circuits Available – C, L, π , T



SPECIFICATIONS

AVX P/N	Current (A)	CKT	CAP (μ F)	DC Voltage	DCR (Ω)	L. dim	Insertion Loss ¹ Per MIL-STD-220, +25°C						
							50 KHz	150 KHz	300 KHz	1 MHz	10 MHz	100 MHz	1 GHz
100 VDC, 1.2–2.8 μF													
JD1AB-125	15.0	C	1.200	100	0.008	0.700	16	27	34	43	60	60	60
JD1AB-704	15.0	C	1.2000	100	0.008	0.700	10	19	28	40	50	60	60
JD2AB-S07	0.50	L2	1.400	100	0.300	1.060	21	40	58	70	70	70	70
JD2AB-S08	1.00	L2	1.400	100	0.210	1.060	19	37	55	70	70	70	70
JD2AB-S10	3.00	L2	1.400	100	0.030	1.060	16	26	37	55	70	70	70
JD2AB-S11	5.00	L2	1.400	100	0.007	1.060	15	25	34	46	70	70	70
JD2AB-S12	10.0	L2	1.400	100	0.006	1.060	15	24	34	44	70	70	70
JD3AB-P07	0.50	π	2.800	100	0.300	1.205	40	70	80	80	80	80	80
JD3AB-P08	1.00	π	2.800	100	0.210	1.205	35	68	80	80	80	80	80
JD3AB-P10	3.00	π	2.800	100	0.030	1.205	13	43	73	80	80	80	80
JD3AB-P11	5.00	π	2.800	100	0.007	1.205	–	26	63	80	80	80	80
JD3AB-P12	10.0	π	2.800	100	0.006	1.205	20	30	40	70	70	80	80
JD4AB-T08	1.00	T	1.400	100	0.500	1.400	21	48	70	70	70	70	70
JD4AB-T09	2.00	T	1.400	100	0.090	1.400	15	26	44	70	70	70	70
JD4AB-T16	4.00	T	1.400	100	0.030	1.400	15	24	35	50	70	70	70
JD4AB-T12	10.0	T	1.400	100	0.005	1.400	14	24	34	44	60	70	70
200 VDC, .45–.9 μF													
JD1BB-904	15.0	C	0.900	200	0.006	0.700	12	21	30	40	53	60	60
JD1BB-454	15.0	C	0.450	200	0.006	0.700	6	16	24	34	51	60	60
JD2BB-S07	0.50	L2	0.450	200	0.300	1.060	10	30	48	65	70	70	70
JD2BB-S08	1.00	L2	0.450	200	0.210	1.060	8	28	45	65	70	70	70
JD2BB-S10	3.00	L2	0.450	200	0.030	1.060	6	16	28	45	60	70	70
JD2BB-S11	5.00	L2	0.450	200	0.007	1.060	6	14	24	36	52	70	70
JD2BB-S12	10.0	L2	0.450	200	0.006	1.060	6	15	24	34	50	70	70
JD3BB-P07	0.50	π	0.900	200	0.300	1.205	15	50	70	80	80	80	80
JD3BB-P08	1.00	π	0.900	200	0.210	1.205	11	46	70	80	80	80	80
JD3BB-P10	3.00	π	0.900	200	0.030	1.205	–	18	50	80	80	80	80
JD3BB-P11	5.00	π	0.900	200	0.007	1.205	–	13	40	70	80	80	80
JD3BB-P12	10.0	π	0.900	200	0.006	1.205	9	20	30	40	55	80	80
JD4BB-T08	1.00	T	0.450	200	3.000	1.400	18	50	70	80	80	80	80
JD4BB-T09	2.00	T	0.450	200	0.210	1.400	12	48	70	80	80	80	80
JD4BB-T16	4.00	T	0.450	200	0.030	1.400	–	18	24	42	80	80	80
JD4BB-T12	10.0	T	0.450	200	0.006	1.400	–	12	22	34	70	80	80

¹ Insertion loss limits are based on theoretical values.
Actual measurements may vary due to internal capacitor resonances and other design constraints.

NOTE: All “L2” circuits are also available as “L1”.
Insertion loss and other parameters are identical.
Only the part number changes (e.g., L2 = GK2LA-S04,
L1 = GK2LA-R04).

Cylindrical Style EMI Filters

JD Series – .690 Dia. – Hermetically Sealed – Circuits Available – C, L, π , T



SPECIFICATIONS

AVX P/N	Current (A)	CKT	CAP (μ F)	DC Voltage	DCR (Ω)	L. dim	Insertion Loss ¹ Per MIL-STD-220, +25°C						
							50 KHz	150 KHz	300 KHz	1 MHz	10 MHz	100 MHz	1 GHz
300 VDC (125 VAC/400Hz*), .3–.36 μF													
JD1LB-304	15.0	C	0.300	300	0.008	0.700	7	16	22	32	46	58	70
JD2LB-S07	0.50	L2	0.300	300	0.330	1.060	13	28	40	60	60	70	70
JD2LB-S08	1.00	L2	0.300	300	0.150	1.060	6	24	37	56	60	70	70
JD2LB-S10	3.00	L2	0.300	300	0.026	1.060	7	17	24	42	70	70	70
JD2LB-S11	5.00	L2	0.300	300	0.013	1.060	7	16	22	34	68	70	70
JD2LB-S12	10.0	L2	0.300	300	0.008	1.060	7	16	20	30	56	70	70
JD3LB-P07	0.50	π	0.360	300	0.330	1.205	14	44	62	80	80	80	80
JD3LB-P08	1.00	π	0.360	300	0.150	1.205	–	37	56	80	80	80	80
JD3LB-P10	3.00	π	0.360	300	0.026	1.205	–	18	40	70	80	80	80
JD3LB-P11	5.00	π	0.360	300	0.013	1.205	–	–	25	60	80	80	80
JD3LB-P12	10.0	π	0.360	300	0.008	1.205	–	–	–	50	80	80	80
JD4LB-T08	1.00	T	0.300	300	0.070	1.400	6	18	28	58	70	70	70
JD4LB-T09	2.00	T	0.300	300	0.050	1.400	6	16	22	37	70	70	70
JD4LB-T16	4.00	T	0.300	300	0.030	1.400	6	16	20	34	70	70	70
JD4LB-T12	10.0	T	0.300	300	0.008	1.400	–	–	19	30	48	60	70
400 VDC (230 VAC/400Hz*), .15–.2 μF													
JD1EB-154	15.0	C	0.150	400	0.008	.700	–	10	16	26	40	52	70
JD2EB-S07	0.50	L2	0.150	400	0.330	1.060	5	24	32	50	60	70	70
JD2EB-S08	1.00	L2	0.150	400	0.150	1.060	–	19	30	46	60	70	70
JD2EB-S10	3.00	L2	0.150	400	0.026	1.060	–	11	19	36	60	70	70
JD2EB-S11	5.00	L2	0.150	400	0.013	1.060	–	10	16	28	54	70	70
JD2EB-S12	10.0	L2	0.150	400	0.008	1.060	–	10	16	25	48	70	70
JD3EB-P07	0.50	π	0.200	400	0.330	1.205	–	34	52	80	80	80	80
JD3EB-P08	1.00	π	0.200	400	0.150	1.205	–	27	46	74	80	80	80
JD3EB-P10	3.00	π	0.200	400	0.026	1.205	–	–	30	60	80	80	80
JD3EB-P11	5.00	π	0.200	400	0.013	1.205	–	–	12	50	80	80	80
JD3EB-P12	10.0	π	0.200	400	0.008	1.205	–	–	–	30	80	80	80
JD4EB-T08	1.00	T	0.150	400	0.070	1.300	–	12	25	48	70	70	70
JD4EB-T09	2.00	T	0.150	400	0.050	1.300	–	10	18	40	64	70	70
JD4EB-T16	4.00	T	0.150	400	0.030	1.300	–	10	16	31	58	70	70
JD4EB-T12	10.0	T	0.150	400	0.008	1.300	–	–	15	25	45	60	70

¹ Insertion loss limits are based on theoretical values.

* Actual measurements may vary due to internal capacitor resonances and other design constraints.

NOTE: All “L2” circuits are also available as “L1”.
Insertion loss and other parameters are identical.
Only the part number changes (e.g., L2 = GK2LA-S04,
L1 = GK2LA-R04).

Advanced Technology Filters



Miniature, Subminiature & Microminiature

APPLICATIONS

AVX's Miniature filter line breaks the "small" size barrier. These ultraminiature products, available as solder-in or screw-in style, have case diameters as low as .073". Threaded filters will allow substitution, flexibility of placement and simple installation, while solder-in parts will provide hermeticity of your microcircuit packages. Now, with capacitance values of up to 50,000 pF, "C", "L" or "T" circuits, superior insertion loss over on-board filtering, variety of ultra small and lightweight sizes, you can meet all "mission critical" objectives. World's smallest and most complete miniature EMI filter line is especially well suited for microwave industry, medical electronics, avionics instrumentation, satellites or other applications where space is at premium.

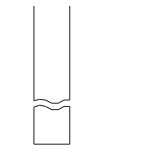
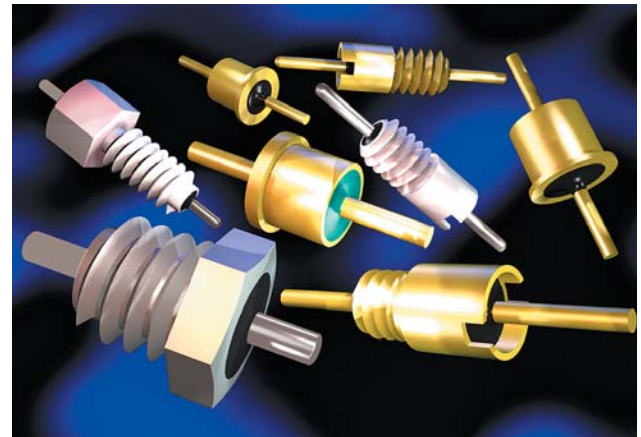

ie "B"

FEATURES

- World's smallest filters, a "must" for avionics and space industry.
- Tiny size for miniaturization of microwave and telecom equipment.
- Hardware real-estate and weight reduction of up to 60%.
- Most complete product offering with solder-in or bolt installation.
- Discoidal capacitor design to meet cost/reliability goals.

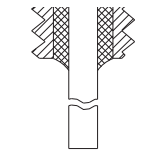

ie "A2"

- | | | |
|------------|----------------|---------------|
| ① - LEAD | ② - CASE | ③ - EPOXY |
| ④ - SOLDER | ⑤ - GLASS SEAL | ⑥ - CAPACITOR |



NOTE: Torque limiting tool with custom adapter available upon request.

SPECIFICATIONS

Mechanical

Material: Solder-In: Case and Leads:
Kovar per ASTM F-15
Screw-in: Case: CRS per ASTM-108
Leads: Copper clad steel
(1-64 & 2-56 Thd.)
Copper (4-40 & 8-36 Thd.)

Finish: Solder-in: Gold per Mil-G-45204
Screw-in: Gold per Mil-G-45204 (standard)
Silver optional (1-64 & 2-56 Thd.)
Silver per QQ-S-365 (standard)
Gold optional (4-40 & 8-36 Thd.)

Electrical

Capacitance: measured @ 1KHz and .1 to 1 VRMS, 25°C
Dissipation factor: 3% max.
Insulation resistance: 10,000 Mohms min. @ 25°C, WVDC;
1000 Mohms min. @ 125°C, WVDC
DC resistance: .02 ohm max.
Dielectric withstanding voltage: 200% of WVDC min.

EMI Filters



Miniature, Subminiature & Microminiature



SCREW-IN STYLE, C TYPE ¹⁻⁶⁴/₂₋₅₆ THD.

SPECIFICATIONS

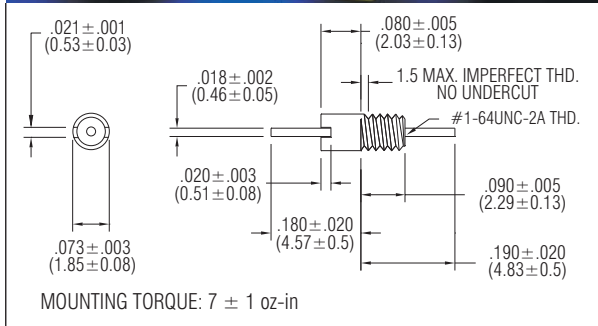

AVX Part Number	Voltage Vdc (V)	Min. Cap (pF)	Current Idc (A)	MINIMUM NO LOAD INSERTION LOSS (db) @ 25°C PER MIL-STD-220					
				10 MHZ	30 MHZ	100 MHZ	300 MHZ	1 GHZ	10 GHZ
SXD1C3-502	50	5000	3	15	22	35	45	55	60
SXD1C3-272	50	2700	3	10	17	30	38	50	60
SXD1A3-152	100	1500	3	5	12	25	33	45	55
SXD1A3-102	100	1000	3	4	10	22	30	42	55
SXD1A3-501	100	500	3	-	-	15	25	35	50
SXD1A3-251	100	250	3	-	-	10	17	27	40
SXD1B3-101	200	100	3	-	-	3	10	20	30
SXD1B3-500	200	50	3	-	-	1	6	15	25
SXD1B3-250	200	25	3	-	-	-	1	10	22
SXD1B3-100	200	10	3	-	-	-	-	3	20
SXD1B3-5R0	200	5	3	-	-	-	-	-	15

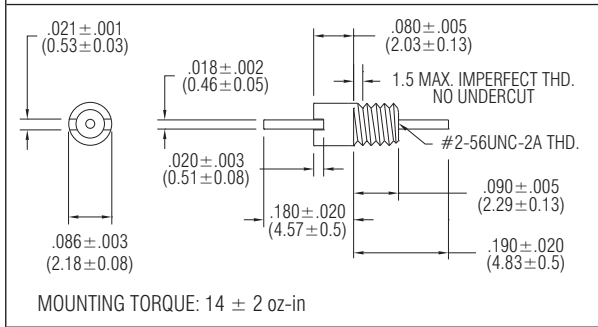

SYD1C3-502	50	5000	3	15	22	35	45	55	60
SYD1C3-272	50	2700	3	10	17	30	38	50	60
SYD1A3-152	100	1500	3	5	12	25	33	45	55
SYD1A3-102	100	1000	3	4	10	22	30	42	55
SYD1A3-501	100	500	3	-	-	15	25	35	50
SYD1A3-251	100	250	3	-	-	10	17	27	40
SYD1B3-101	200	100	3	-	-	3	10	20	30
SYD1B3-500	200	50	3	-	-	1	6	15	25
SYD1B3-250	200	25	3	-	-	-	1	10	22
SYD1B3-100	200	10	3	-	-	-	-	3	20
SYD1B3-5R0	200	5	3	-	-	-	-	-	15

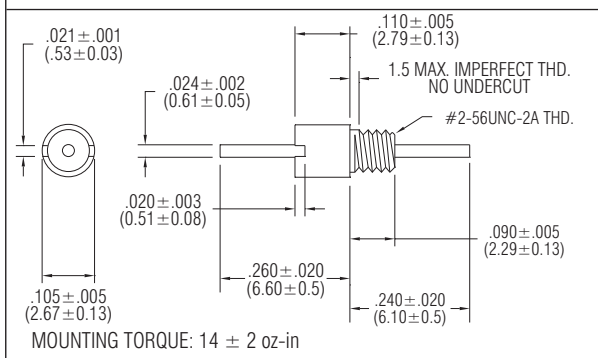

SZD1C3-273	50	27000	5	30	37	43	53	65	70
SZD1C3-103	50	10000	5	20	27	37	47	60	65
SZD1A3-502	100	5000	5	15	22	35	45	55	60
SZD1A3-272	100	2700	5	10	17	30	38	50	60
SZD1A3-152	100	1500	5	5	12	25	33	45	55
SZD1B3-102	200	1000	5	4	10	22	30	42	55
SZD1B3-501	200	500	5	-	-	15	25	35	50
SZD1B3-251	200	250	5	-	-	10	17	27	40
SZD1B3-101	200	100	5	-	-	3	10	20	30
SZD1B3-500	200	50	5	-	-	1	6	15	25
SZD1B3-250	200	25	5	-	-	-	1	10	22
SZD1B3-100	200	10	5	-	-	-	-	3	20
SZD1B3-5R0	200	5	5	-	-	-	-	-	15

NOTE: Dimensions in inches (millimeters). Torque limiting tool with custom adapter required for proper installation (see page 2)

CONFIGURATION OPTIONS

Terminals



“SZD” and “SYD” Parts Only
Slotted terminal available
on one or both sides

Mounting

- .090 Thd. Length Standard, intended for tapped hole feed through mounting
- .140 Thd. Length available for through hole mounting with hex nut

Schematic

- "C" STANDARD
- THD. END "L1" AVAILABLE WITH EXTENDED CASE LENGTH
-

AVX FILTERS SOLDER-IN STYLE FILTER

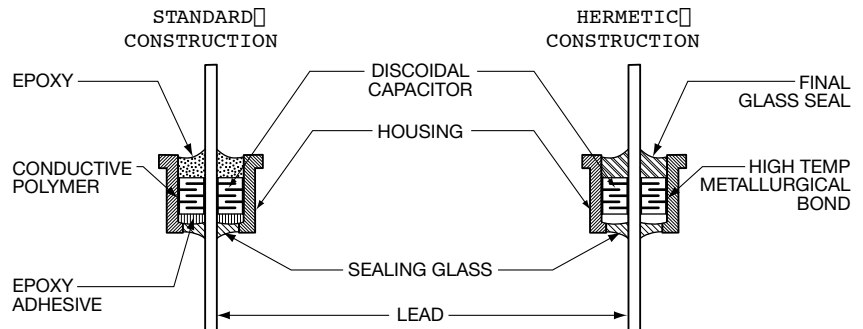
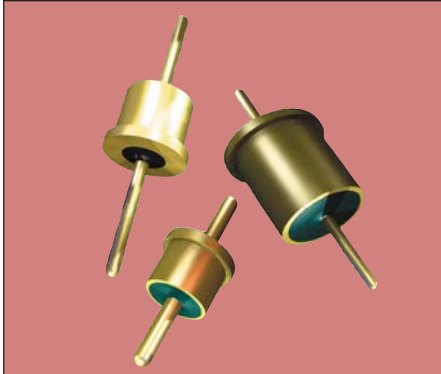

GENERAL DESCRIPTION

These are high frequency filters in space saving solder-in designs which will operate under harsh environments and meet the high reliability requirements of MIL-F-28861 without outgassing. AVX Filters Corporation has designed a filter which sets a new standard for the industry. These feed-thru filters are constructed with hi-rel semiconductor materials and rugged MLC discoidal capacitors. They are also manufactured at high temperatures (>500°C) without fluxes, epoxies or other polymers, thus eliminating failure mechanisms associated with conventional solder-ins. These solder-ins withstand short temperature excursions as high as 400°C, and can actually be operated at temperatures to 200°C. Available either as discrete packages in standard case sizes or as multiple filter brackets, all have hermetic glass-to-metal seals on both ends.

FEATURES

- Standard sizes
- Epoxy free construction
- Hermetic on both ends
- MIL-C-123 Discoidal Capacitor
- 400°C installation

STYLE

- Discrete, hermetically sealed solder-in filters

AVX Filters Series*

WQ: .400" Case Diameter

XQ: .250" Case Diameter

YQ: .165" Case Diameter

ZQ: .128" Case Diameter

*Equivalent to MIL-F-28861 Series FS70, FS71, FS72, FS73 and FS74

- Custom design available
- Multiple filter arrays
 - Custom bracket housing employing discrete hermetic filters
 - Custom rugged bracket housings with inter-rated hermetic filtered feed-thrus

SPECIFICATIONS

- Operating temperature range: -55°C to 200°C
- 400°C rated installation temperature
- Voltage range: 50 to 300 VDC/up to 200 VAC
- Capacitance Range: 10 pF to 1.4 mF
- Hermeticity: 1×10^{-7} ATM cm³/sec minimum
- Rated current: up to 25 amps
- Circuits: C
- Designed to meet or exceed requirements of MIL-F-28861

CHARACTERISTICS

- Rugged monolithic ceramic capacitor construction
- Capacitor attached with solderless, fluxless, high temperature metallurgical bond
- Hermetic glass-to-metal seals on both ends
- No epoxies, resins or polymers to outgas or degrade in harsh environments

Filter Plates



Custom Designed Filter Plates

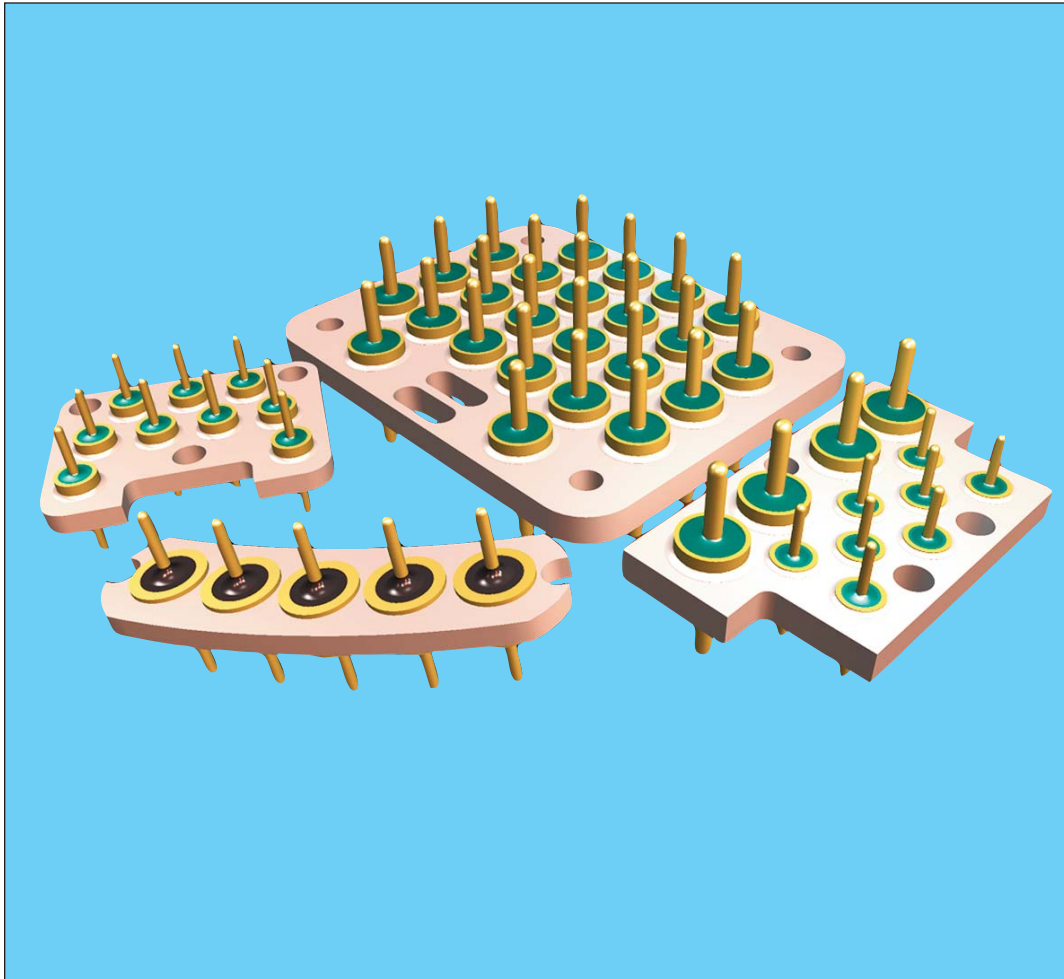

AVX solder-in style filters are designed to be soldered into bulkheads, plates, and/or assemblies similar to those depicted in the photograph above. AVX Filters will design and fabricate bracket arrays to your specific requirements or Source Control Drawing.

The mechanical stress and extreme temperatures encountered by the filters during installation into assemblies is normally the harshest environment they will experience during the life of a system.

If you are buying the discrete filters and doing the installation in house you should seriously consider:

- How much is it costing you to purchase burned-in and fully tested filters only to damage them during the installation procedure?
- How much is it costing you to test for component integrity after installation?
- How much is it costing you to rework damaged filter assemblies at your labor rates and overhead?
- How much is it costing you to contend with low assembly yields?
- How much is it costing you to inventory a larger number of line items than necessary?

AVX Filters will design and fabricate filter brackets:

- To your specific requirements.
- 100% tested and burned-in prior to delivery.
- Which utilize the superior solder-in style filters (Series ZZ, ZS, XS, WS) capable of withstanding installation temperatures up to 300°C, or
- Which utilize the new hermetic solder-in when harsh environments or other requirements call for true hermetic components.

A custom designed filter bracket will help:

- To reduce your yield losses.
- To eliminate filter rework in assemblies.
- To reduce system assembly costs.
- To minimize your inventory.

For additional information on filter brackets or design assistance, contact the AVX Filters Application Engineering Department.

SPECIFICATIONS AND CAPABILITIES

Size:

Basically unlimited. The physical size is determined by the quantity and style (WS, YS, etc.) of filters selected.

Construction:

Hand fabricated or machined metallic (steel, brass, aluminum, or other alloys) bracket.

Finish Options:

The bracket can be electro-tin plated, gold plated, anodized, chem film, painted, or as specified by the customer.

The individual filter terminals can be gold plated or solder coated.

Electrical Characteristics:

The following electrical parameters are governed by the individual types of filters selected or as dictated by the customer's Source Control Drawing or specific application.

- Voltage Rating
- Current Rating
- Insulation Resistance
- DWV
- DC Resistance
- Insertion Loss
- Operating Temperature

Discrete Components:

The number of components, individual circuits, can range from 2 to 200 filters of different styles and/or electrical characteristics (WS, YS, etc.) and can be combined to form a single custom assembly.

Discrete Component Testing:

QPL and/or QPL equivalents can be utilized.

Discoidal capacitors can be designed and tested to the requirements of MIL-C-123.

The individual filters can be specified with MIL-F-15733, AVX Filters Level R, MIL-F-28861 Class B or Class S reliability levels (see Reliability section of catalog for description) or as dictated by the customer's Source Control Drawing or specific application.

Bracket Assembly:

The complete bracket assembly can be tested to similar requirements as the individual filters.

Hermeticity:

Some brackets are more cost effective and volumetrically efficient as non-hermetic assemblies where application allows.

Most brackets can be manufactured to provide a hermetic barrier (glass-to-metal seal) on one side of the assembly.

There are true hermetic brackets, glass-to-metal seals on both sides available, but only in a capacitive circuit.

Installation Temperature:

Filter bracket assemblies are capable of withstanding installation temperatures up to 300°C.

Additional Assembly Operations:

Wiring harnesses or flex cables can be attached to the complete assembly and completely tested prior to delivery.

Environmental Considerations:

Capable of meeting the applicable portions of MIL-STD-202 and MIL-STD-810.

High Reliability

M28861 SCREENING

The Group A sequence as outlined in MIL-F-28861 is performed on a 100% basis whenever Reliability Codes for Class S or Class B are specified by the customer. Differences

between Class S and Class B screening are shown in the descriptions.

S-CLASS, B-CLASS TESTING

Test	MIL-STD-202 (method)	Description
Thermal Shock	107, cond. A	S-class: 5 cycles from -55°C to +125°C. Through-hole mounting required. B-class: as above except mounting not required.
Burn-in	108	S-class: 168 hours minimum at 2.0X rated voltage, 125°C polarity reversal for the first 24-72 hours; fused B/I circuit for each filter. B-class: 164 ± 4 hours at 2.0X rated voltage.
Dielectric Withstanding Voltage	301	S-class, B-class: 2.5X rated DC voltage for 5 seconds minimum, 1 minute maximum, 50 mA charging current.
Insulation Resistance	302, cond. A	S-class: test at 100 VDC or rated, V, whichever is less. Pass/fail limits are also based upon 125°C reading from first 50 pieces. B-class: same as above, except omit pass/fail as per 50 piece calculation.
Capacitance and D.F.	305	S-class, B-class: test 1000 ± 100 Hz, 0.1 to 1.2 VRMS
Insertion Loss	—	S-class, B-class: per MIL-STD 220 at load, no-load as specified.
DC Resistance	303	S-class, B-class: test is optional if DC Voltage Drop Test performed.
Voltage Drop	—	S-class, B-class: M28861 para. 4.6.6.1 (AC rated), para 4.6.6.2 (DC rated)
Radiographic Inspect.	209	S-class, B-class: 2 views required with 10X examination images.
Seal Test	112	S-class: condition C, B-class: condition A or D
Visual and Mechanical	—	S-class: M28861 para 4.6.1.2 which includes element, subassembly, and pre-cap inspections, B-class: M28861 para 4.6.3 for external visual only.
Solderability	208	S-class, B-class: 5 samples.

R-LEVEL SCREENING

The test sequence outlined below is performed whenever AVX Filters R-level screening is specified. Each filter lot is subjected to the tests in the order shown on a 100% basis.

Summary data is provided for R-level Screening and is included with shipment.

R-LEVEL TESTING

Test	MIL-STD-202 (method)	Description
Thermal Shock	107, cond. A	5 cycles from -55°C to +125°C.
Burn-in	108, cond. A	100 hours at 1.4 times rated voltage, ±125°C.
Dielectric Withstanding Voltage	301	Twice (2X) rated DC voltage for 5 ± 1 sec at 25°C, 50 mA maximum charging current.
Insulation Resistance	302, cond. A	Testing performed at rated DC voltage. The 125°C value shall be 10% of the specified IR at 25°C.
Seal Test	112, cond. A	Gross leak test. Not applicable to epoxy-sealed units.
Depolarization	—	1 hour at 150°C. No voltage applied.
Capacitance and D.F.	305	Test signal 1KHz, 1.0 VRMS.
DC Resistance	303	DCR measured in lieu of voltage drop.
Insertion Loss	—	Per MIL-F-15733 para 4.6.9.1 (check test)
Visual and Mechanical	—	Per MIL-F-15733 para. 4.6.1

Screw & Locking Washer Table



HEX NUT AND INTERNAL TOOTH LOCKWASHER

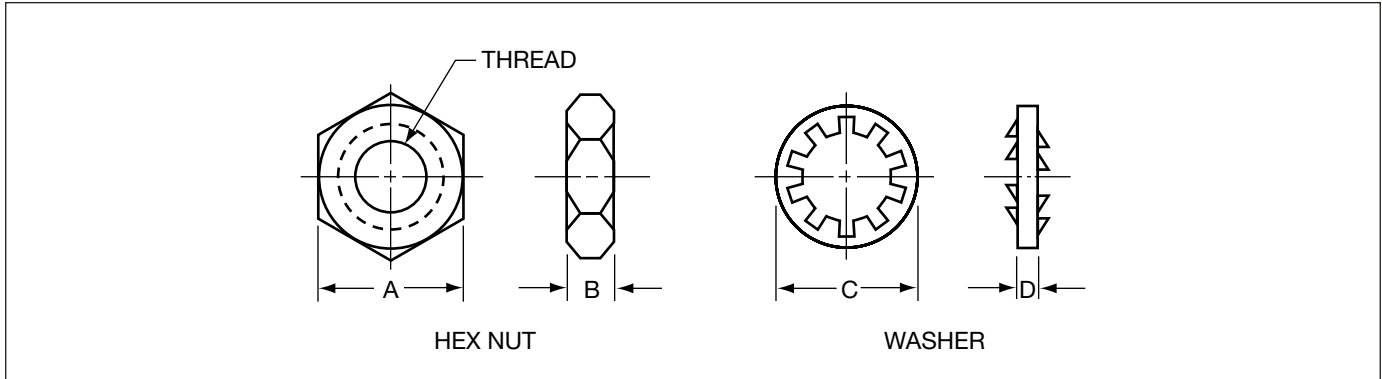

Size Thread		Hex Nut		Lockwasher	
		A	B	C	D
4-40 UNC-2B (.112-40)	(STD)	<u>.187*</u> .180	<u>.067*</u> .057	<u>.225*</u> .215	<u>.020*</u> .010
	(ALT)	<u>.257</u> .241	<u>.083</u> .073	<u>.265</u> .255	<u>.018</u> .012
8-32 UNC-2B (.164-32)	(STD)	<u>.250*</u> .241	<u>.083*</u> .073	<u>.285*</u> .275	<u>.025*</u> .015
	(ALT)	<u>.313</u> .307	<u>.114</u> .104	<u>.336</u> .325	<u>.025</u> .015
10-32 UNF-2B (.190-32)	(STD)	<u>.250</u> .241	<u>.080</u> .070	<u>.311</u> .300	<u>.023</u> .013
	(ALT)	<u>.345</u> .336	<u>.130</u> .120	<u>.381</u> .370	<u>.027</u> .017
12-32 UNEF-2B (.216-32)	(STD)	<u>.250</u> .241	<u>.083</u> .073	<u>.383</u> .372	<u>.023</u> .013
	(ALT)	<u>.250*</u> .241	<u>.073*</u> .063	<u>.383*</u> .372	<u>.023*</u> .013
1/4-28 UNF-2B (.250-28)		<u>.311*</u> .308	<u>.096*</u> .091	<u>.408*</u> .396	<u>.021*</u> .015
5/16-24 UNF-2B (.312-24)		<u>.377*</u> .365	<u>.096*</u> .091	<u>.435*</u> .425	<u>.027*</u> .017

*Used for MIL-F-28861 units.

Thread	Recommended Mounting Torque
(.112-40) 4-40 UNC-2A	32 oz-in. ± 4 oz-in.
(.164-32) 8-32 UNC-2A	64 oz-in. ± 4 oz-in.
(.190-32) 10-32 UNC-2A	64 oz-in. ± 4 oz-in.
(.216-32) 12-32 UNEF-2A	64 oz-in. ± 4 oz-in.
(.250-28) 1/4-28 UNF-2A	44 oz-in. ± 4 oz-in.
(.312-24) 5/16-24 UNF-2A	60 oz-in. ± 4 oz-in.

C FEED-THRU FILTER		<p>A feedthru is a low inductance device, acting as a bypass feedthru capacitor to ground. It works well with a high impedance load and source. For assured contact, it should be soldered directly to a bulkhead or a connector base.</p>
L FILTER		<p>This adds a series-inductive element to the bypass feedthru capacitor connected to ground. Because of the inductor, it can be connected to a low impedance source or load. This filter may be used to link a low impedance source to a high impedance load, or vice versa, with the feedthru capacitor facing the high impedance circuit.</p>
π FILTER		<p>This filter contains two feedthru capacitors connected to ground with an inductor in-between. It presents a low impedance to both the source and load, and has a sharper roll-off than either the feed-thru or L-section designs. With feedthru capacitors as outer elements, this filter is best suited for high impedance load and source applications.</p>
T FILTER		<p>This filter forms a 'T' with two inductors and a feedthru capacitor connected to ground. Like the π Filter, it has a sharper roll-off than a feedthru or an L-section design. With inductors as outer elements, the T-section is intended for applications with a low impedance load and source. It also finds application where transient conditions may occur (EMP, lighting, etc).</p>

INSERTION LOSS

The insertion loss values specified throughout this catalog are based upon an industry standard of full load and balanced 50 ohm system in accordance with MIL-STD-220A (at +25°C). The actual attenuation performance in other circuits will vary significantly with different values of source and load impedance.

The insertion loss values in this catalog may appear to be significantly lower than that of comparable filters in certain other competitor catalogs. The reason for this is that AVX Filters takes into account both component and circuit resonances and adjusts the table values such that the insertion loss will not drop below straight lines drawn between each data point in a semilog graph.

**I.L. vs. FREQUENCY
(FOR VARIOUS FILTER CONFIGURATIONS)**

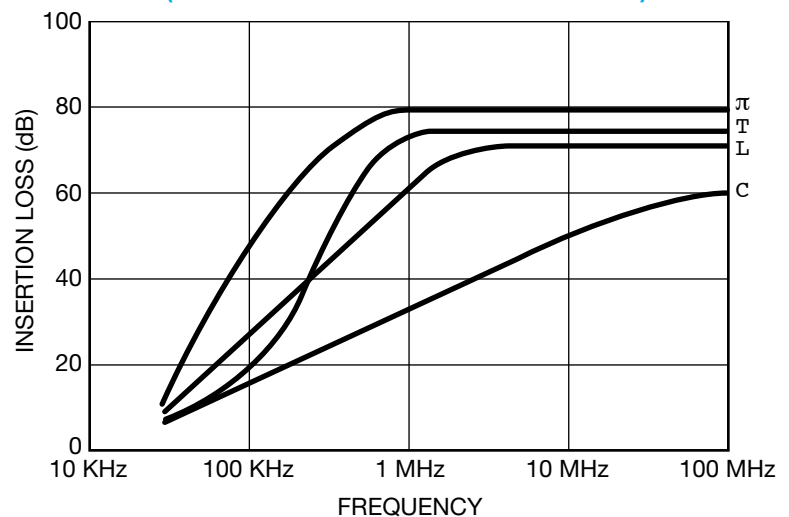

INSTALLATION, HANDLING, HARDWARE OPTIONS

GENERAL

Proper Electrical Operation Requires:

- Good filter/case ground.
- Design layout where filter is installed directly into conductive shield or enclosure.
- Minimizing holes, slots, or other penetrations of the shield near the filter.

Installation Precautions

- Although EMI/RFI filters can withstand temperature extremes, rapid heat-up or cool-down can crack the internal ceramic capacitor.
 - Pre-heating of the filter prior to soldering should be performed whenever possible.
 - Forced-air cooling after soldering is not recommended.

Avoid Mechanical Stress

- Do not use pliers or other gripping tools capable of exerting excessive pressure on filter case.
- Do not alter the lead or terminal flag either before or after soldering.

SPECIFIC RECOMMENDATIONS

Hi-Temp Solder-In Style Filter

- Small case design sensitive to excessive heating.
- 150°C preheat prior to solder installation using supplied solder preform highly recommended.
- Vapor phase reflow (VPR) soldering with integral preheat is preferred.
- Infrared (IR) and hot plate soldering may also be used.
- Temperature should be increased to solder temperature (300°C, max.) at a controlled rate of 2°C per second.
- Time at max. temperature should be kept at a minimum and should never exceed 30 seconds.
- When soldering leads using an iron:
 - Iron tip temperature should not exceed 460°F (60/40 solder recommended).
 - Use a small iron, 15-20 watts, and do not apply heat for longer than 10 seconds.
 - Use of heat sink clip when lead length permits is recommended.
- Do not expose leads to torque stresses by moving wires after soldering to lead. The glass hermetic seal may be damaged.

- Do not cut or form filter leads.
 - Mechanical stress may be transmitted to the discoidal capacitor.
 - The glass hermetic seal may be damaged.
 - Contact AVX Filters regarding custom lead lengths to accommodate your requirements.

Bolt-Style Filters

- Do not exceed recommended nut mounting torques listed on next page. NOTE: it is preferable to keep to the low side of torque range when installing filters into threaded mounting holes.
- On epoxy sealed bolt-style units AVX Filters recommends conformal coating of the units after installation to improve moisture resistance.
- Observe same precautions listed for hi-temp filter when soldering to filter center pin.
- Do not bend filter center pin.

Cylindrical-Style Filters

- Observe recommended nut mounting torque as per the table on next page.
 - BK, CK, GK – series filters (1/4-28 UNF-2A) require 44 ± 4 oz-in.
 - JD series (5/16-24 UNF-2A) require 60 ± 4 oz-in.
- The terminal flags should not be subjected to mechanical stress during or after leadwire installation. The glass hermetic seal may be adversely affected.
- Use care in soldering to the terminal flags. An 18-30 watt soldering iron is recommended. CAUTION: the use of a large wattage iron without temperature control may cause reflow of the high-temperature solder used to seal the terminal. This could result in the loss of hermeticity for the filter.

HARDWARE OPTIONS

General

- Necessary mounting hardware is supplied with all filters.
- Hex nut and lockwasher plating will be as per filter case specified.
- Refer to table for hardware selection. Standard hardware (“STD”) will be supplied unless otherwise requested. MIL-F-28861 filters will be shipped with MIL-F-28861 hardware.

**Only ZXS, ZYS, and ZZS are RoHS compliant and leadfree.
All other products are considered Not RoHS Compliant unless otherwise indicated**

There have been many questions raised regarding the differences between MIL-F-15733 and MIL-F-28861. To clarify these differences we have incorporated the following

Analysis Chart which compares the differences between these two military specifications.

ANALYSIS MIL-F-15733 vs. MIL-F-28861			
Characteristics	MIL-F-15733	MIL-F-28861	
	Filter Design/Construction	Filter Design/Construction	
		Class B	Class S
CASE	Standard	Standard	Standard
CAPACITOR (Discoidal) • Dielectrics • K • VTL • Cap Range	Standard X7R, Z5U 2200-10K N/A Max Cap/Case Size	Special Design BR 2K max +15%, -40% Limited Cap/Case Size Conservation Design	Special Design BX 2K max +15%, -25% (when design permits) Limited Cap/Case Size & MIL-C-123 Req'ts Conservative Design
	Testing	Testing	
GROUP A • Test • PDA (parts defective allowed)	MIL-STD-105, 1.0% AQL None	100% Test 10%	100% Test Thermal Shock, Burn-in*, IR & DWV-2% each test Cap, Volt. Drop, Insertion Loss <u>-3% max</u> combined Total 10% max
X-RAY	None	MIL-STD-202 Method 209	MIL-STD-202 Method 209
LEAK TEST	Condition "A" Gross Leak	Condition "A" Gross Leak PDA 10% max	Condition "A" Gross Leak Condition "C" Fine Leak PDA 10% max
BURN-IN	None generally. A few slash sheets require 1.4 x rated voltage	160 Hrs. @ 2 x rated voltage — Resistor protected	168 Hrs. (250 Hrs. max) @ 2 x rated voltage - Fuse protected *PDA .2% max lasts 50 Hrs.
INSERTION LOSS	1.0% AQL	100%	100%
SOLDERABILITY	None	MIL-STD-202 Method 208 5 Samples	MIL-STD-202 Method 208 5 Samples

Notes

NOTE 1: CAPACITANCE CODE

All AVX Filters part numbers, with exception of certain cylindrical styles, show total filter capacitance using the 3-digit EIA code. The first two digits are significant: the last digit is the multiplier.

Example: 103=10000 picofarads
125=1200000 picofarads
(1.2 microfarads)

It is important to note that π filters and multisection filters are described using the EIA code from the standpoint of total capacitance. Capacitance is understood to be specified as “guaranteed minimum value” (GMV) unless otherwise specified. AVX Filters can supply $\pm 20\%$ or other specified tolerances at an additional charge. Contact AVX Filters Applications Engineering for further information.

NOTE 2: RELIABILITY CODES

The customer must select the reliability code to be consistent with the filter application. As a minimum, all catalog filters are available as R-level designs.

Options:

- “-” signifies an R-level filter design without the optional R-level high-rel screening
- “R” R-level design with optional R-level high-rel screening also specified
- “B” Class B design with Group A screening per M28861 for Class B filters
- “S” Class S design with Group A screening per M28861 for Class S (space grade) filters

Please refer to the catalog section on Reliability for additional information on how to select reliability codes.

NOTE 3: SPECIAL DESIGN CODE (ASSIGNED BY AVX FILTERS)

A special suffix to the standard part number will be added by AVX Filters Applications Engineering to describe special designs or designs that are controlled by customer specifications. It is important to note that even in those instances where a customer drawing describes a standard catalog design it is AVX Filters policy to assign a special part number to the customer drawing for configuration control.

NOTE 4: VOLTAGE CODES AND FILTER VOLTAGE RATINGS

IMPORTANT: please contact AVX Filters Applications Engineering when considering DC-rated filter designs for possible use in AC applications. As a general rule, DC designs may be derated for AC applications. Let us assist you.

The voltage code letters must be selected consistent with the capabilities as outlined in the product selection tables for a given filter type. It is important to note that the same code letter may signify a different voltage rating depending upon filter type. For example: the “L” code signifies a 200 VDC/125 VAC rating for a bolt-style filter, but it describes a 300 VDC/125 VAC design when applied to a JD-style filter.

NOTE 5: TERMINAL AND LEADWIRE CODES

Non-standard terminal configurations including special materials or finishes are available. Please indicate a description and/or outline drawing when requesting a non-standard terminal (code “3”).

NOTE 6: SPECIAL INFORMATION FOR CYLINDRICAL STYLE FILTERS

L-section filter designs must be specified with regard to “standard” or “reverse” configuration. The L-section filter is normally utilized with the capacitor on the high impedance side of the circuit and the inductor looking into the low impedance side. Compact filter types such as the BK2 or CK2 button filters with ferrite bead inductors are only supplied with the bead assembled into the threaded end. GK2 and JD2 L-section filters are normally supplied with a schematic or other marking to indicate location of the inductor.

AC-rated catalog designs incorporate reduced values of capacitance to limit reactive current heating (and subsequent filter temperature rise) to safe levels. Do not specify a DC-rated filter with larger capacitance for an AC application without contacting AVX Filters Applications Engineering.

How To Order



Part Number Construction

SOLDER-IN STYLE

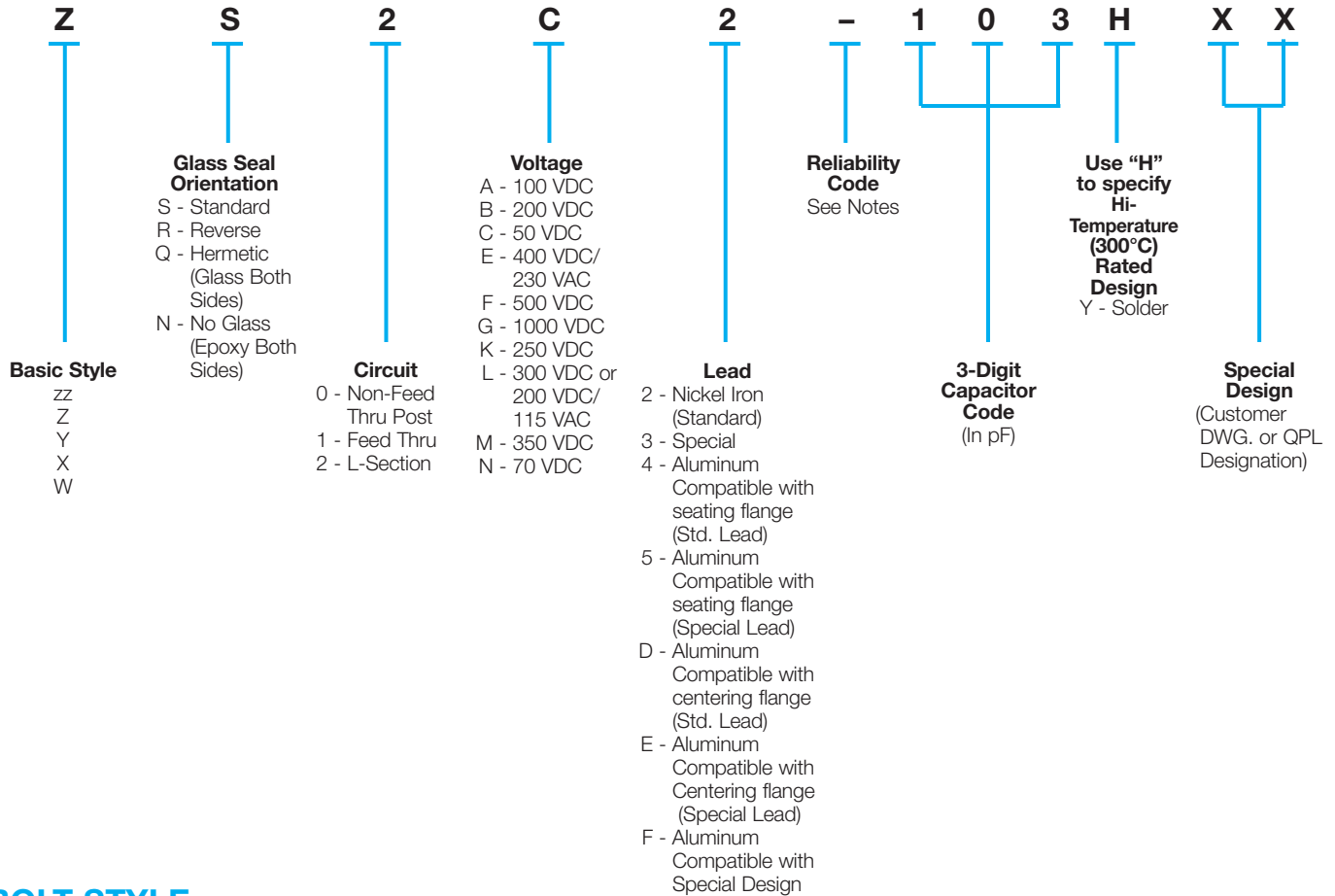

BOLT STYLE

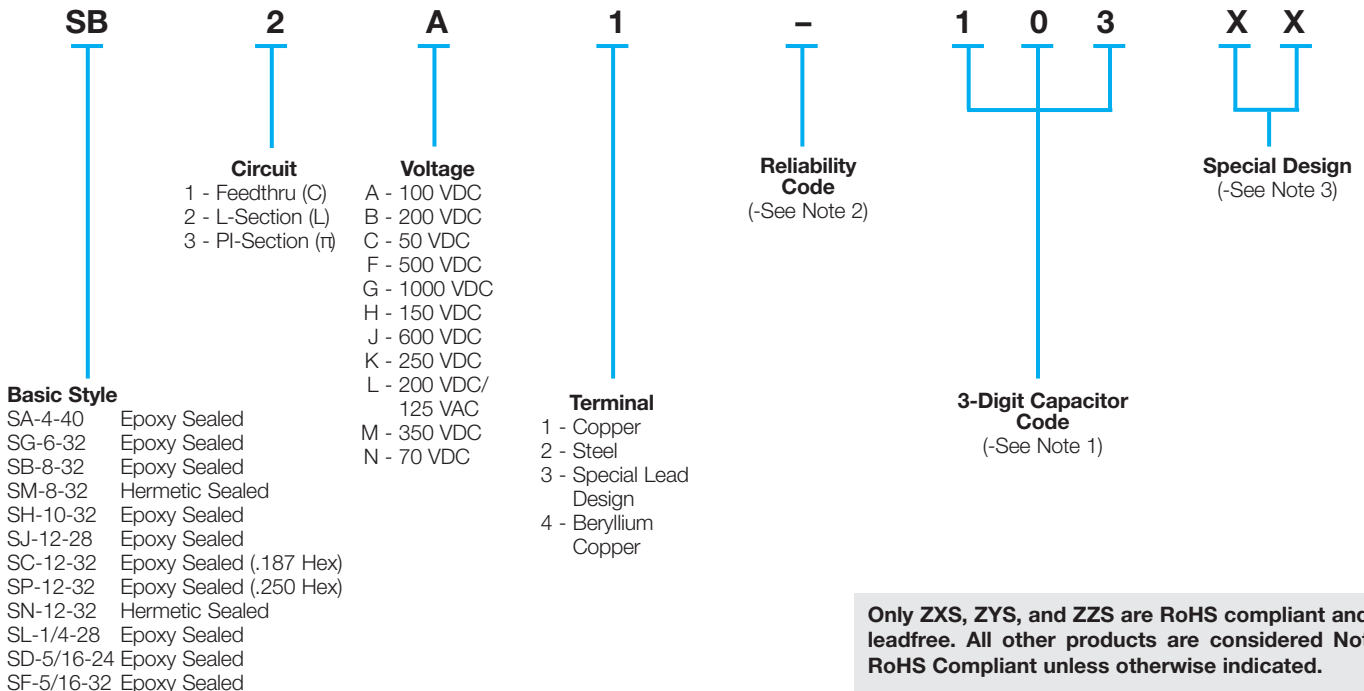

Only ZXS, ZYS, and ZZS are RoHS compliant and leadfree. All other products are considered Not RoHS Compliant unless otherwise indicated.

How To Order



Part Number Construction

CYLINDRICAL STYLE

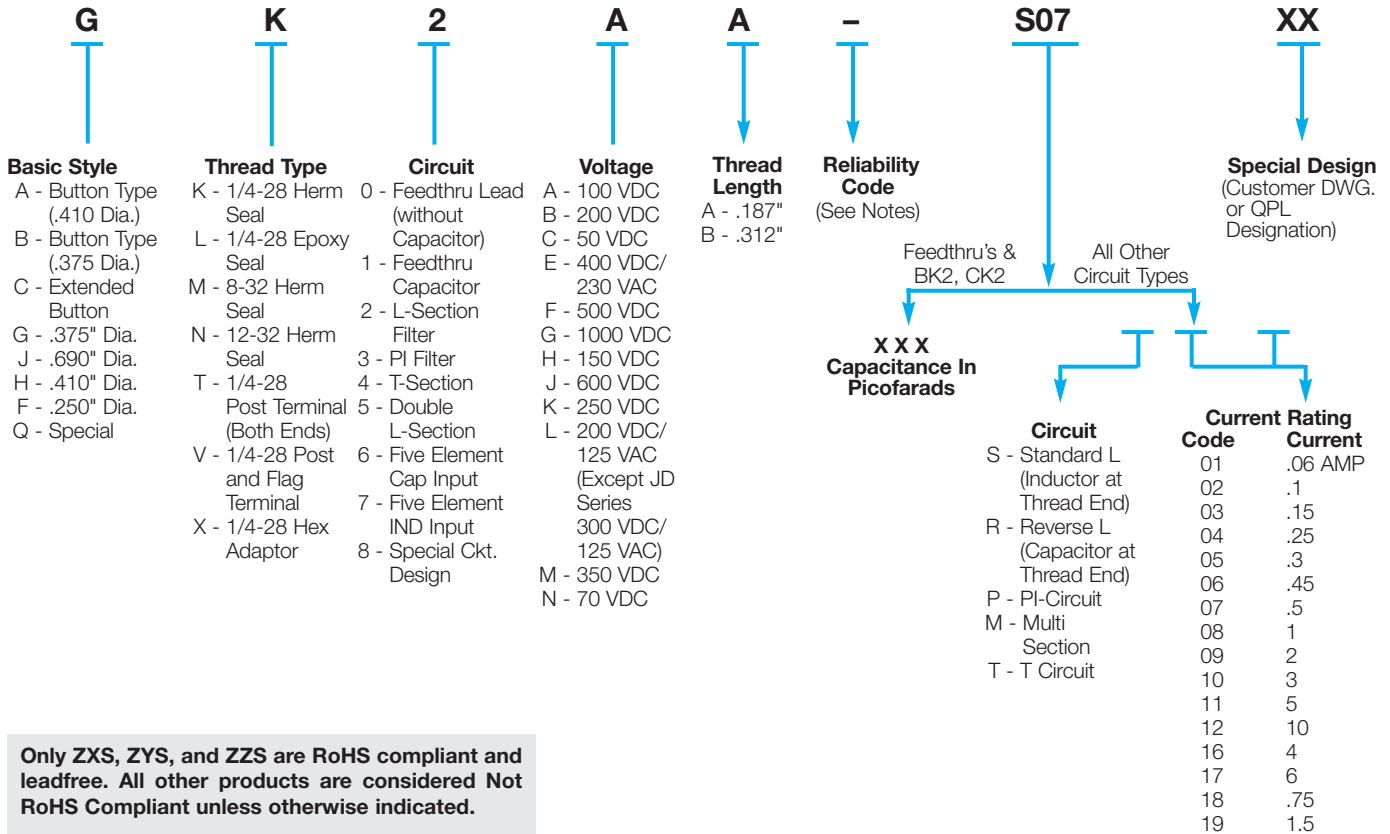

Only ZXS, ZYS, and ZZS are RoHS compliant and leadfree. All other products are considered Not RoHS Compliant unless otherwise indicated.

Please contact the factory for Filter Plates and other custom product part numbers.

NOTICE: Specifications are subject to change without notice. Contact your nearest AVX Sales Office for the latest specifications. All statements, information and data given herein are believed to be accurate and reliable, but are presented without guarantee, warranty, or responsibility of any kind, expressed or implied. Statements or suggestions concerning possible use of our products are made without representation or warranty that any such use is free of patent infringement and are not recommendations to infringe any patent. The user should not assume that all safety measures are indicated or that other measures may not be required. Specifications are typical and may not apply to all applications.

AMERICAS

AVX Greenville, SC
Tel: 864-967-2150

AVX Northwest, WA
Tel: 360-699-8746

AVX Midwest, IN
Tel: 317-861-9184

AVX Mid/Pacific, CA
Tel: 408-988-4900

AVX Northeast, MA
Tel: 617-479-0345

AVX Southwest, CA
Tel: 949-859-9509

AVX Canada
Tel: 905-238-3151

AVX South America
Tel: +55-11-4688-1960

EUROPE

AVX Limited, England
Tel: +44-1276-697000

AVX S.A.S., France
Tel: +33-1-69-18-46-00

AVX GmbH, Germany
Tel: +49-0811-95949-0

AVX SRL, Italy
Tel: +39-02-614-571

AVX Czech Republic
Tel: +420-57-57-57-521

AVX/ELCO UK
Tel: +44-1638-675000

ELCO Europe GmbH
Tel: +49-2741-299-0

AVX S.A., Spain
Tel: +34-91-63-97-197

AVX Benelux
Tel: +31-187-489-337

ASIA-PACIFIC

**AVX/Kyocera (S) Pte Ltd.,
Singapore**
Tel: +65-6286-7555

**AVX/Kyocera, Asia, Ltd.,
Hong Kong**
Tel: +852-2363-3303

**AVX/Kyocera Yuhan Hoesa,
South Korea**
Tel: +82-2785-6504

**AVX/Kyocera HK Ltd.,
Taiwan**
Tel: +886-2-2656-0258

**AVX/Kyocera (M) Sdn Bhd,
Malaysia**
Tel: +60-4228-1190

**AVX/Kyocera International
Trading Co. Ltd.,
Shanghai**
Tel: +86-21-3255 1933

**AVX/Kyocera Asia Ltd.,
Shenzen**
Tel: +86-755-3336-0615

**AVX/Kyocera International
Trading Co. Ltd.,
Beijing**
Tel: +86-10-6588-3528

**AVX/Kyocera India
Liaison Office**
Tel: +91-80-6450-0715

ASIA-KED

(KYOCERA Electronic Devices)

KED Hong Kong Ltd.
Tel: +852-2305-1080/1223

**KED Hong Kong Ltd.
Shenzen**
Tel: +86-755-3398-9600

**KED Company Ltd.
Shanghai**
Tel: +86-21-3255-1833

**KED Hong Kong Ltd.
Beijing**
Tel: +86-10-5869-4655

KED Taiwan Ltd.
Tel: +886-2-2950-0268

**KED Korea Yuhan Hoesa,
South Korea**
Tel: +82-2-783-3604/6126

**KED (S) Pte Ltd.
Singapore**
Tel: +65-6509-0328

**Kyocera Corporation
Japan**
Tel: +81-75-604-3449

Contact:



<http://www.avx.com>

S-USM0M1114-C