

GXCAS Technology

High-Accuracy Digital Temperature Sensor IC

DESCRIPTION

The GXTS03 is GXCAS's new high accuracy digital temperature sensor. Its functionality includes enhanced signal processing, two distinctive and user selectable I2C addresses and communication speeds of up to 1 MHz. The DFN package has a footprint of 3 x 3 mm² while keeping a height of 0.75 mm. This allows for integration of the GXTS03 into a great variety of applications. Additionally, the wide supply voltage range of 1.6 V to 5.5 V guarantees compatibility with a wide range of applications.

FEATURES

- Fully calibrated and linearized digital output
- Wide supply voltage range, from 1.6 V to 5.5 V
- I2C Interface with communication speeds up to 1MHz and two user selectable addresses
- Typical accuracy of $\pm 0.3\text{ }^{\circ}\text{C}$
- Very fast start-up and measurement time
- Measures Temperatures from $-45\sim 130\text{ }^{\circ}\text{C}$
- $\pm 0.1\text{ }^{\circ}\text{C}$ Accuracy from $35\text{ }^{\circ}\text{C}$ to $+45\text{ }^{\circ}\text{C}$
Thermometer Resolution is 16 Bits
- Converts Temperature to 16-Bit Digital Word in 2ms
- 8-Pin DFN package

Content

1	Sensor Performance.....	2
2	Specifications	3
3	Pin Assignment	5
4	Operation and Communication.....	6
5	Package Outline.....	12
6	Recommended Land Pattern.....	14
7	Ordering Information.....	14

PIN CONFIGURATIONS

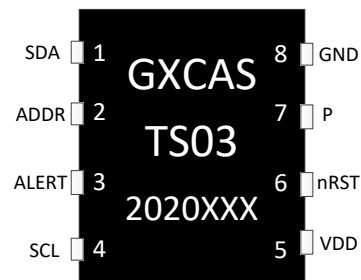

1 Sensor Performance

1.1 Temperature Sensor Performance

Parameter	Condition	Value	Units
Accuracy tolerance	typ., 35°C to 45°C	±0.1	°C
Accuracy tolerance	typ., 0°C to 90°C	±0.3	°C
Repeatability	Low	0.24	°C
	Medium	0.12	°C
	High	0.06	°C
Resolution	Typ.	0.015	°C
Specified Range	-	-40 to 125	°C
Response time	$\tau_{63\%}$	>1	s
Long Term Drift	max	<0.02	°C/y

Table 1 Temperature sensor specification.

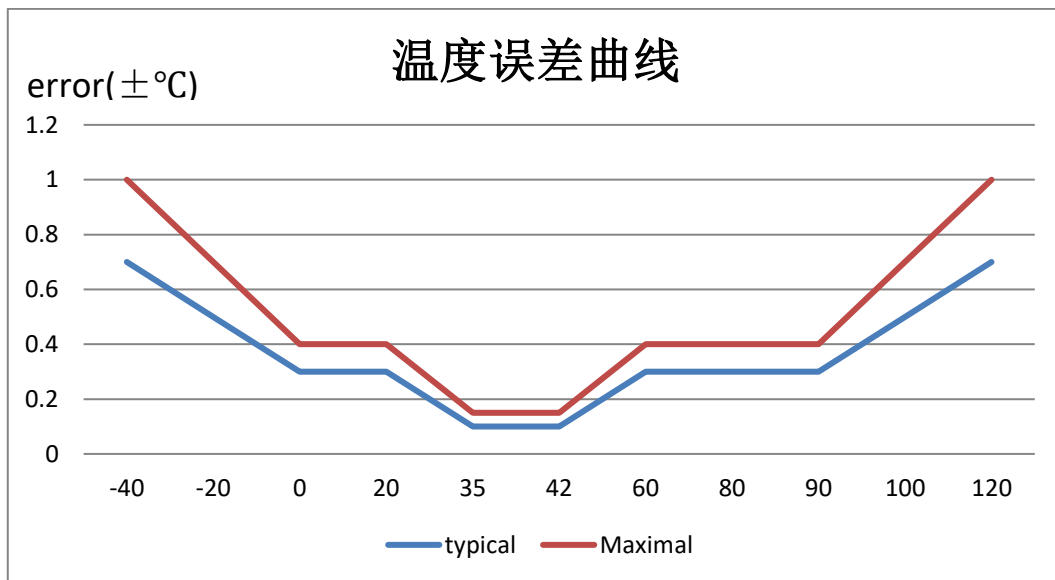

Figure 2 Temperature accuracy of the GXTS03 sensor.

2 Specifications

2.1 Electrical Specifications

Parameter	Symbol	Condition	Min.	Typ.	Max.	Units	Comments
Supply voltage	V _{DD}		1.6	3.3	5.5	V	
Power-up/down level	V _{POR}		2.2	2.3	2.4	V	
Slew rate change of the supply voltage	V _{DD,slew}		-	-	20	V/ms	Voltage changes on the VDD line between V _{DD,min} and V _{DD,max} should be slower than the maximum slew rate
Supply current	I _{DD}	idle state (single shot mode)	-	0.15	2.0	μA	Current when sensor is not performing a measurement during single shot mode
		idle state (periodic data acquisition mode)	-	45	70	μA	Current when sensor is not performing a measurement during periodic data acquisition mode
		Measuring	-	600	1200	μA	Current consumption while sensor is measuring
		Average	-	2	5	μA	Current consumption (operation with one measurement per second at lowest repeatability, single shot mode)
Alert Output driving strength	IOH		0.8x V _{DD}	1.5x V _{DD}	2.1x V _{DD}	mA	See also section 3.5

Table 2 Electrical specifications, valid at 25°C and typical VDD.

2.2 Timing Specification for the Sensor System

Parameter	Symbol	Conditions	Min.	Typ.	Max.	Units	Comments
Power-up time	t _{PU}	After hard reset, V _{DD} ≥ V _{POR}	-	0.5	1	ms	Time between V _{DD} reaching V _{POR} and sensor entering idle state
Soft reset time	t _{SR}	After soft reset.	-	0.5	1	ms	Time between ACK of soft reset command and sensor entering idle state
Duration of reset pulse	t _{RESETN}		350	-	-	ns	See section 3.6
Measurement duration	t _{MEAS,l}	Low repeatability		2	4	ms	The three repeatability modes differ with respect to measurement duration, noise level and energy consumption
	t _{MEAS,m}	Medium repeatability		4.5	6	ms	
	t _{MEAS,h}	High repeatability		12.5	15	ms	

Table 3 System timing specification, valid from -40 °C to 125 °C and 1.6 V to 5.5 V.

2.3 Absolute Minimum and Maximum Ratings

Stress levels beyond those listed in Table 4 may cause permanent damage to the device or affect the reliability of the sensor. These are stress ratings only and functional operation of the device at these conditions is not guaranteed.

Parameter	Rating	Units
Supply voltage V_{DD}	-0.3 to 6	V
Max Voltage on pins (pin 1 (SDA); pin 2 (ADDR); pin 3 (ALERT); pin 4 (SCL); pin 6 (nRESET))	-0.3 to $V_{DD}+0.3$	V
Input current on any pin	± 100	mA
Operating temperature range	-40 to 125	$^{\circ}\text{C}$
Storage temperature range	-40 to 150	$^{\circ}\text{C}$
ESD HBM (human body model) ⁴	4	kV
ESD CDM (charge device model) ⁵	750	V

Table 4 Minimum and maximum ratings; values may only be applied for short time periods.

⁴ Sensor in application configuration (pin 7 connected to VSS). ESD HBM 2 kV according to JEDEC JS-001.

⁵ According to JEDEC JS-002.
www.galaxy-cas.com

3 Pin Assignment

The GXT03 comes in a tiny 8-pin DFN package – see Table 5.

Pin	Name	Comments
1	SDA	Serial data; input / output
2	ADDR	Address pin; input; connect to either VDD or VSS, do not leave floating ADDR=0 I2C_address is 0X44 ADDR=1 I2C_address is 0X45
3	ALERT	Indicates alarm condition; output; must be left floating if unused
4	SCL	Serial clock; input / output
5	VDD	Supply voltage; input
6	nRESET	Reset pin active low; input; if not used it is recommended to left floating
7	P	No electrical function; recommended to connect to VSS
8	G	Ground

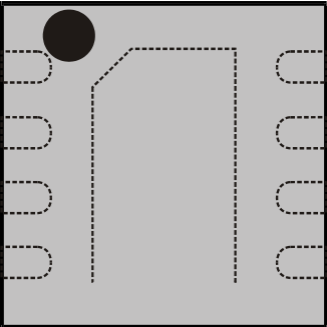

pull-up resistors (please refer to Figure 4). A device on the I2C bus must only drive a line to ground. The external pull-up resistors (e.g. $R_p=4.7\text{ k}\Omega$) are required to pull the signal high. For dimensioning resistor sizes please take bus capacity and communication frequency into account (see for example Section 7.1 of NXPs I2C Manual for more details⁶). It should be noted that pull-up resistors may be included in I/O circuits of microcontrollers. It is recommended to wire the sensor according to the application circuit as shown in Figure 4.

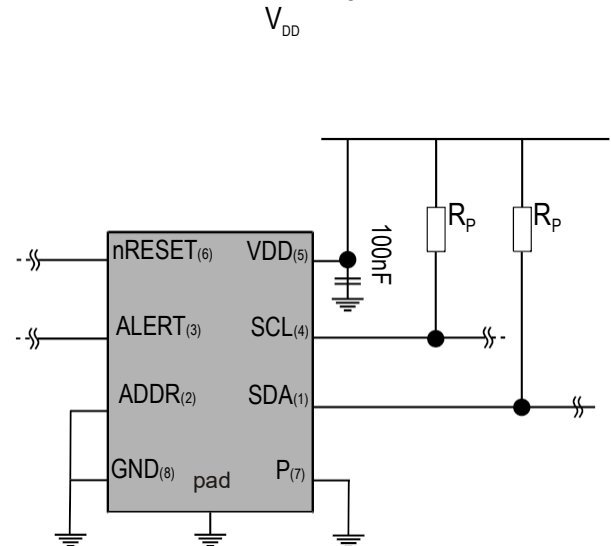

Figure 4 Typical application circuit. Please note that the positioning of the pins does not reflect the position on the real sensor. This is shown in Table 5.

4 Operation and Communication

The GXTS03 supports I2C fast mode (and frequencies up to 1000 kHz). Clock stretching can be enabled and disabled through the appropriate user command. For detailed information on the I2C protocol, refer to NXP I2C-bus specification⁷.

All GXTS03 commands and data are mapped to a 16-bit address space. Additionally, data and commands are protected with a CRC checksum. This increases communication reliability. The 16-bit commands to the sensor already include a 3-bit CRC checksum. Data sent from and received by the sensor is always succeeded by a 8-bit CRC.

In write direction it is mandatory to transmit the checksum, since the GXTS03 only accepts data if it is followed by the correct checksum. In read direction it is left to the master to read and process the checksum.

4.1 Power-Up and Communication Start

The sensor starts powering-up after reaching the power-up threshold voltage V_{POR} specified in Table 2. After reaching this threshold voltage the sensor needs the time t_{PU} to enter idle state. Once the idle state is entered it is ready to receive commands from the master (microcontroller).

Each transmission sequence begins with a START condition (S) and ends with a STOP condition (P) as described in the I2C-bus specification. The stop condition is optional. Whenever the sensor is powered up, but not performing a measurement or communicating, it automatically enters idle state for energy saving. This idle state cannot be controlled by the user.

4.2 Starting a Measurement

A measurement communication sequence consists of a START condition, the I2C write header (7-bit I2C device address plus 0 as the write bit) and a 16-bit measurement command. The proper reception of each byte is indicated by the sensor. It pulls the SDA pin low (ACK bit) after the falling edge of the 8th SCL clock to indicate the reception. A complete measurement cycle is depicted in Table 7.

With the acknowledgement of the measurement command, the GXTS03 starts measuring the temperature.

4.3 Measurement Commands for Single Shot Data Acquisition Mode

In this mode one issued measurement command triggers the acquisition of a 16-bit temperature value. During transmission that value is always followed by a CRC checksum, see section 4.4.

In single shot mode different measurement commands can be selected. The 16-bit commands are shown in Table 7. They differ with respect to repeatability (low, medium and high) and clock stretching (enabled or disabled).

The repeatability setting influences the measurement duration and thus the overall power consumption of the sensor. This is explained in section 2.2.

4.4 Readout of Measurement Results for Single Shot Mode

After the sensor has completed the measurement, the master can read the measurement result by sending a START condition followed by an I2C read header. The sensor will acknowledge the reception of the read header and send one byte of data (temperature) followed by one byte CRC checksum. Each byte must be acknowledged by the microcontroller with an ACK condition for the sensor to continue sending data. If the sensor does not receive an ACK from the master after any byte of data, it will not continue sending data.

After receiving the checksum for the temperature value a NACK and stop command should be sent by the master (see Table 7).

The I2C master can abort the read transfer with a NACK condition after any data byte if it is not interested in the CRC.

In case the user needs the temperature data but does not want to process CRC data, it is recommended to read the two temperature bytes, then the read transfer can be aborted with a NACK.

No Clock Stretching

When a command without clock stretching has been issued, the sensor responds to a read header with a not acknowledge (NACK), if no data is present.

Clock Stretching

When a command with clock stretching has been issued, the sensor responds to a read header with an ACK and subsequently pulls down the SCL line. The SCL line is pulled down until the measurement is complete. As soon as the measurement is complete, the sensor releases the SCL line and sends the measurement results.

Condition		Hex. code	
Repeatability	Clock stretching	MSB	LSB
High	enabled	0x2C	06
Medium			0D
Low			10
High	disabled	0x24	00
Medium			0B
Low			16

e.g. 0x2C06: high repeatability measurement with clock stretching enabled

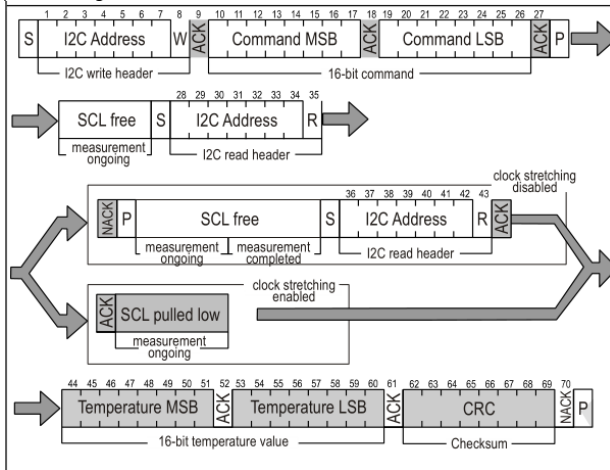

Table 7 Measurement commands in single shot mode (Clear blocks are controlled by the microcontroller, grey blocks by the sensor)

4.5 Measurement Commands for Periodic Data Acquisition Mode

In this mode one issued measurement command yields a stream of 16 bit temperature values.

In periodic mode different measurement commands can be selected. The corresponding 16 bit commands are shown in Table 8. They differ with respect to repeatability (low, medium and high) and data acquisition frequency (0.5, 1, 2, 4 & 10 measurements per second, mps). Clock stretching cannot be selected in this mode.

The data acquisition frequency and the repeatability setting influences the measurement duration and the current consumption of the sensor. This is explained in section 2.2 of this datasheet.

If a measurement command shall be issued, while the sensor is busy with a measurement (measurement durations see Table 3), it is recommended to issue a break command first (see section 4.7). Upon reception of the break command the sensor will finish the ongoing measurement and enter the single shot mode.

Condition		Hex. code	
Repeatability	mps	MSB	LSB
High	0.5	0x20	32
Medium			24
Low			2F
High	1	0x21	30
Medium			26
Low			2D
High	2	0x22	36
Medium			20
Low			2B
High	4	0x23	34
Medium			22
Low			29
High	10	0x27	37
Medium			21
Low			2A

e.g. 0x2130: 1 high repeatability mps - measurement per second

Table 8 Measurement commands for periodic data acquisition mode (Clear blocks are controlled by the microcontroller, grey blocks by the sensor). N.B.: At the highest mps setting self-heating of the sensor might occur.

4.6 Readout of Measurement Results for Periodic Mode

Transmission of the measurement data can be initiated through the fetch data command shown in Table 9. If no measurement data is present the I2C read header is responded with a NACK (Bit 9 in Table 9) and the communication stops. The fetch data command will deliver the same data until a new measurement updates the temperature value.

Command	Hex code
Fetch Data	0x E0 00

Table 9 Fetch Data command (Clear blocks are controlled by the microcontroller, grey blocks by the sensor)

4.7 Break command / Stop Periodic Data Acquisition Mode

The periodic data acquisition mode can be stopped using the break command shown in Table 10. It is recommended to stop the periodic data acquisition prior to sending another command (except Fetch Data command) using the break command. Upon reception of the break command the sensor enters the single shot mode, after finishing the ongoing measurement. This can take up to 15 ms, depending on the selected repeatability.

Command	Hex Code
Break	0x3093

Table 10 Break command (Clear blocks are controlled by the microcontroller, grey blocks by the sensor).

4.8 Reset

A system reset of the GXTS03 can be generated externally by issuing a command (soft reset) or by sending a pulse to the dedicated reset pin (nReset pin). Additionally, a system reset is generated internally during power-u. During the reset procedure the sensor will not process commands.

In order to achieve a full reset of the sensor without removing the power supply, it is recommended to use the nRESET pin of the GXTS03.

Interface Reset

If communication with the device is lost, the following signal sequence will reset the serial interface: While leaving SDA high, toggle SCL nine or more times. This must be followed by a Transmission Start sequence preceding the next command. This sequence resets the interface only. The status register preserves its content.

Soft Reset / Re-Initialization

The GXTS03 provides a soft reset mechanism that forces the system into a well-defined state without removing the power supply. When the system is in idle state the soft reset command can be sent to the GXTS03. This triggers the sensor to reset its system controller and reloads calibration data from the memory. In order to start the soft reset procedure the command as shown in Table 11 should be sent.

It is worth noting that the sensor reloads calibration data prior to every measurement by default.

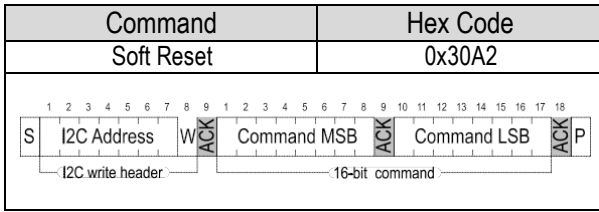

Table 11 Soft reset command (Clear blocks are controlled by the microcontroller, grey blocks by the sensor)

Reset through General Call

Additionally, a reset of the sensor can also be generated using the “general call” mode according to I2C-bus specification⁷. This generates a reset which is functionally identical to using the nReset pin. It is important to understand that a reset generated in this way is not device specific. All devices on the same I2C bus that support the general call mode will perform a reset. Additionally, this command only works when the sensor is able to process I2C commands. The appropriate command consists of two bytes and is shown in Table 12.

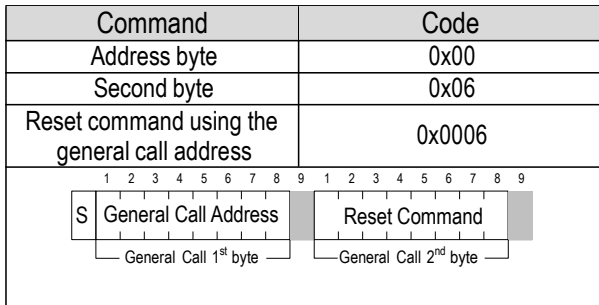

Table 12 Reset through the general call address (Clear blocks are controlled by the microcontroller, grey blocks by the sensor).

Reset through the nReset Pin

Pulling the nReset pin low (see Table 5) generates a reset similar to a hard reset. The nReset pin is internally connected to VDD through a pull-up resistor and hence active low. The nReset pin has to be pulled low for a minimum of 350 ns to generate a reset of the sensor.

Hard Reset

A hard reset is achieved by switching the supply voltage to the VDD Pin off and then on again. In order to prevent powering the sensor over the ESD diodes, the voltage to pins 1 (SDA), 4 (SCL) and 2 (ADDR) also needs to be removed.

4.10 Status Register

The status register contains information on the operational status of the heater, the alert mode and on the execution status of the last command and the last write sequence. The command to read out the status register is shown in Table 14 whereas a description of the content can be found in Table 16.

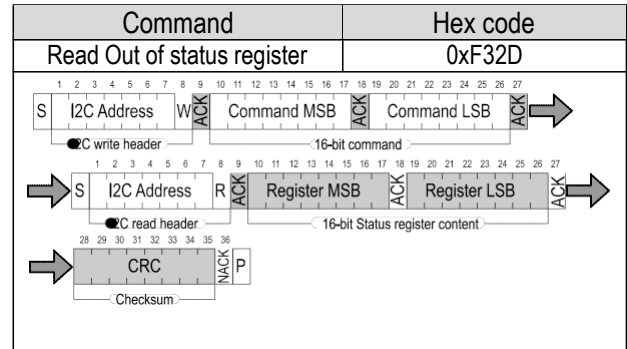

Clear Status Register

All flags (Bit 15, 10, 4) in the status register can be cleared (set to zero) by sending the command shown in Table 15.

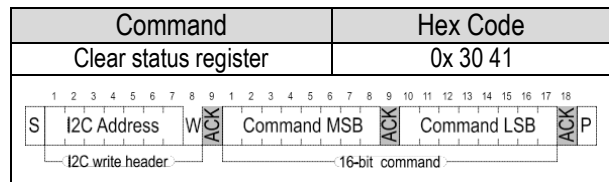

Table 15 Command to clear the status register (Clear blocks are controlled by the microcontroller, grey blocks by the sensor)

Bit	Field description	Default value
15	Alert pending status '0': no pending alerts '1': at least one pending alert	'1'
14	Reserved	'0'
13	Heater status '0': Heater OFF '1': Heater ON	'0'
12:11	Reserved	'00'
10	T tracking alert '0': no alert '1': alert	'0'
9:5	Reserved	'xxxx'
4	System reset detected '0': no reset detected since last 'clear status register' command '1': reset detected (hard reset, soft reset command or supply fail)	'1'
3:2	Reserved	'00'
1	Command status '0': last command executed successfully '1': last command not processed. It was either invalid, failed the integrated command checksum	'0'
0	Write data checksum status '0': checksum of last write transfer was correct '1': checksum of last write transfer failed	'0'

Table 16 Description of the status register.

4.11 Checksum Calculation

The 8-bit CRC checksum transmitted after each data word is generated by a CRC algorithm. Its properties are displayed in Table 17. The CRC covers the contents of the two previously transmitted data bytes. To calculate the checksum only these two previously transmitted data bytes are used.

Property	Value
Name	CRC-8
Width	8 bit
Protected data	read and/or write data
Polynomial	0x31 ($x^8 + x^5 + x^4 + 1$)
Initialization	0xFF
Reflect input	False
Reflect output	False
Final XOR	0x00
Examples	CRC (0xBEEF) = 0x92

Table 17 I2C CRC properties.

4.12 Conversion of Signal Output

Measurement data is always transferred as 16-bit values (unsigned integer). These values are already linearized and compensated for supply voltage effects. Converting those raw values into a physical scale can be achieved using the following formulas.

Temperature conversion formula (result in °C & °F):

$$T [^{\circ}\text{C}] = -45 + 175 \cdot \frac{S_T}{2^{16} - 1}$$

$$T [^{\circ}\text{F}] = -49 + 315 \cdot \frac{S_T}{2^{16} - 1}$$

S_T denotes the raw sensor output for temperature. The formulas work only correctly when S_T is used in decimal representation.

4.13 Communication Timing

Parameter	Symbol	Conditions	Min.	Typ.	Max.	Units	Comments
SCL clock frequency	f_{SCL}		0	-	1000	kHz	
Hold time (repeated) START condition	$t_{HD,STA}$	After this period, the first clock pulse is generated	0.24	-	-	μs	
LOW period of the SCL clock	t_{LOW}		0.65	-	-	μs	
HIGH period of the SCL clock	t_{HIGH}		0.26	-	-	μs	
SDA hold time	$t_{HD,DAT}$		60	-	250	ns	Transmitting data
			0	-	-	ns	Receiving data
SDA set-up time	$t_{SU,DAT}$		100	-	-	ns	
SCL/SDA rise time	t_R		-	-	300	ns	
SCL/SDA fall time	t_F		-	-	300	ns	
SDA valid time	$t_{VD,DAT}$		-	-	0.9	μs	
Set-up time for a repeated START condition	$t_{SU,STA}$		0.6	-	-	μs	
Set-up time for STOP condition	$t_{SU,STO}$		0.6	-	-	μs	
Capacitive load on bus line	CB		-	-	400	pF	
Low level input voltage	V_{IL}		-0.5	-	$0.3 \times V_{DD}$	V	
High level input voltage	V_{IH}		$0.7 \times V_{DD}$	-	$1 \times V_{DD}$	V	
Low level output voltage	V_{OL}	3 mA sink current	-	-	0.66	V	

Table 18 Communication timing specifications for I2C fm (fast mode), Specification are at 25°C and typical VDD . The numbers above are values according to the I2C Specification (UM10204, Rev. 6, April 4, 2014).

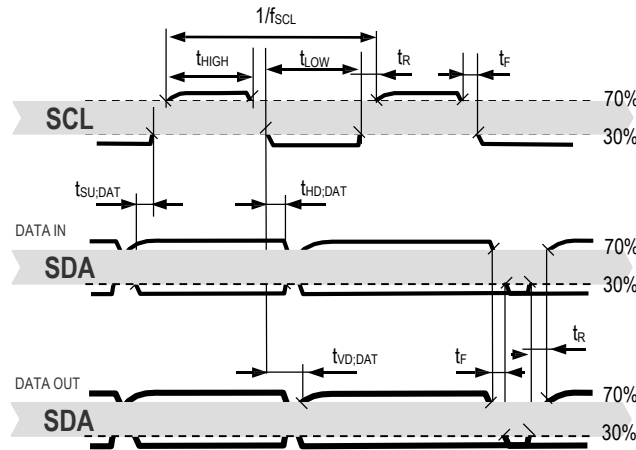
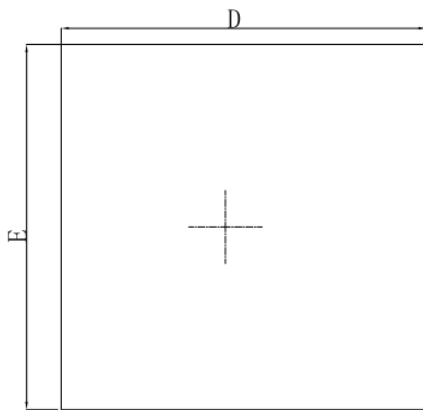

Figure 5 Timing diagram for digital input/output pads. SDA directions are seen from the sensor. Bold SDA lines are controlled by the sensor, plain SDA lines are controlled by the micro-controller. Note that SDA valid read time is triggered by falling edge of preceding toggle.

5 Package Outline

5.1 GXTS03 (DFN8L 3.0*3.0)



Top-view

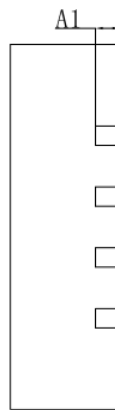

Side-view

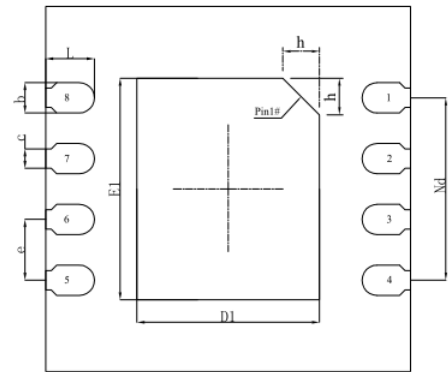

Bottom-view



Side-view

SYMBOL	MILLIMETER		
	MIN	NOM	MAX
A	0.70	0.75	0.80
A1	0.19	0.20	0.21
b	0.20	0.25	0.30
c	0.20REF		
D	2.90	3.00	3.10
E	2.90	3.00	3.10
D1	1.40	1.50	1.60
E1	1.75	1.85	1.95
e	0.50		
h	0.20	0.30	0.40
L	0.35	0.40	0.45
N	8		
Nd	1.50		

5.2 GXTS03T (DFN8 2.5*2.5)

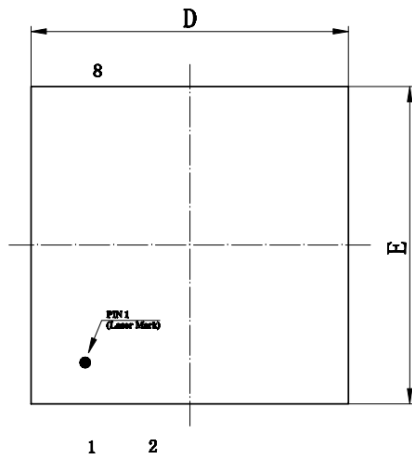

TOP VIEW

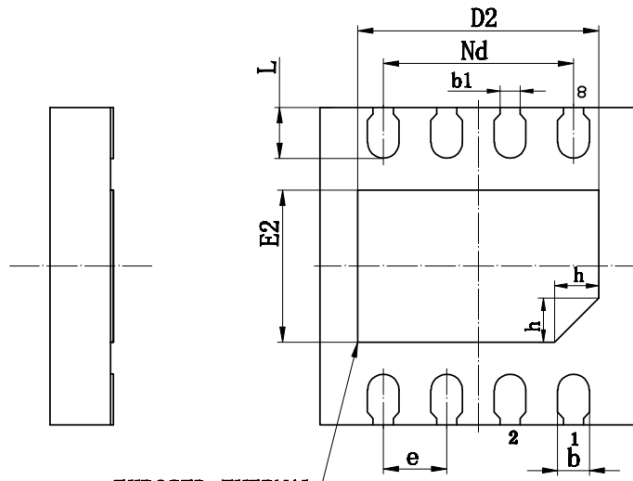

EXPOSED THERMAL
PAD ZONE

BOTTOM VIEW

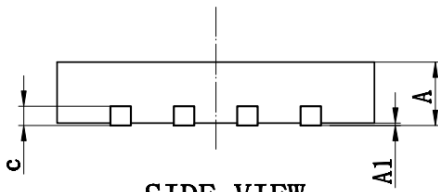

SIDE VIEW

SYMBOL	MILLIMETER		
	MIN	NOM	MAX
A	0.45	0.50	0.55
A1	0	0.02	0.05
b	0.20	0.25	0.30
b1	0.16REF		
c	0.10	0.15	0.20
D	2.40	2.50	2.60
D2	1.80	1.90	2.00
e	0.50BSC		
Nd	1.50BSC		
E	2.40	2.50	2.60
E2	1.10	1.20	1.30
L	0.35	0.40	0.45
h	0.30	0.35	0.40
L/规格尺寸 (mm)	82X55		

6 Recommended Land Pattern

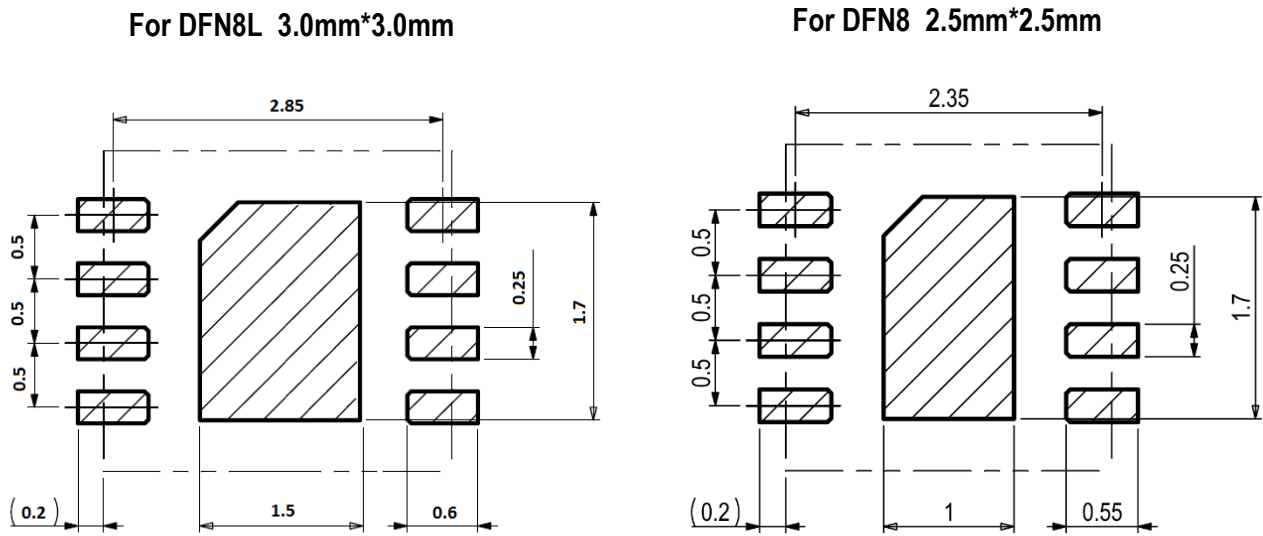

7 Ordering Information

Order Number	Chip Model	Package	SPQ	Note
GXTS03D-T&R	GXTS03D	DFN8L (3mm*3mm)	2000	Tape & Reel
GXTS03T-T&R	GXTS03T	DFN8 (2.5mm*2.5mm)	2000	Tape & Reel

Revision History :

- V1.5 to V1.6 (Sep. 2025) :
Updated Ordering Information.
- V1.4 to V1.5 (May.2025) :
Added Ordering Information.
- V1.3 to V1.4 (May.2025) :
Added DFN8(2.5mm * 2.5mm) package. (see Section 5, Section 6).