

Jun.1.2024 Copyright 2024 HIROSE ELECTRIC CO., LTD. All Rights Reserved.  
 In case of consideration for using Automotive equipment / device which demand high reliability, kindly contact our sales window correspondents.

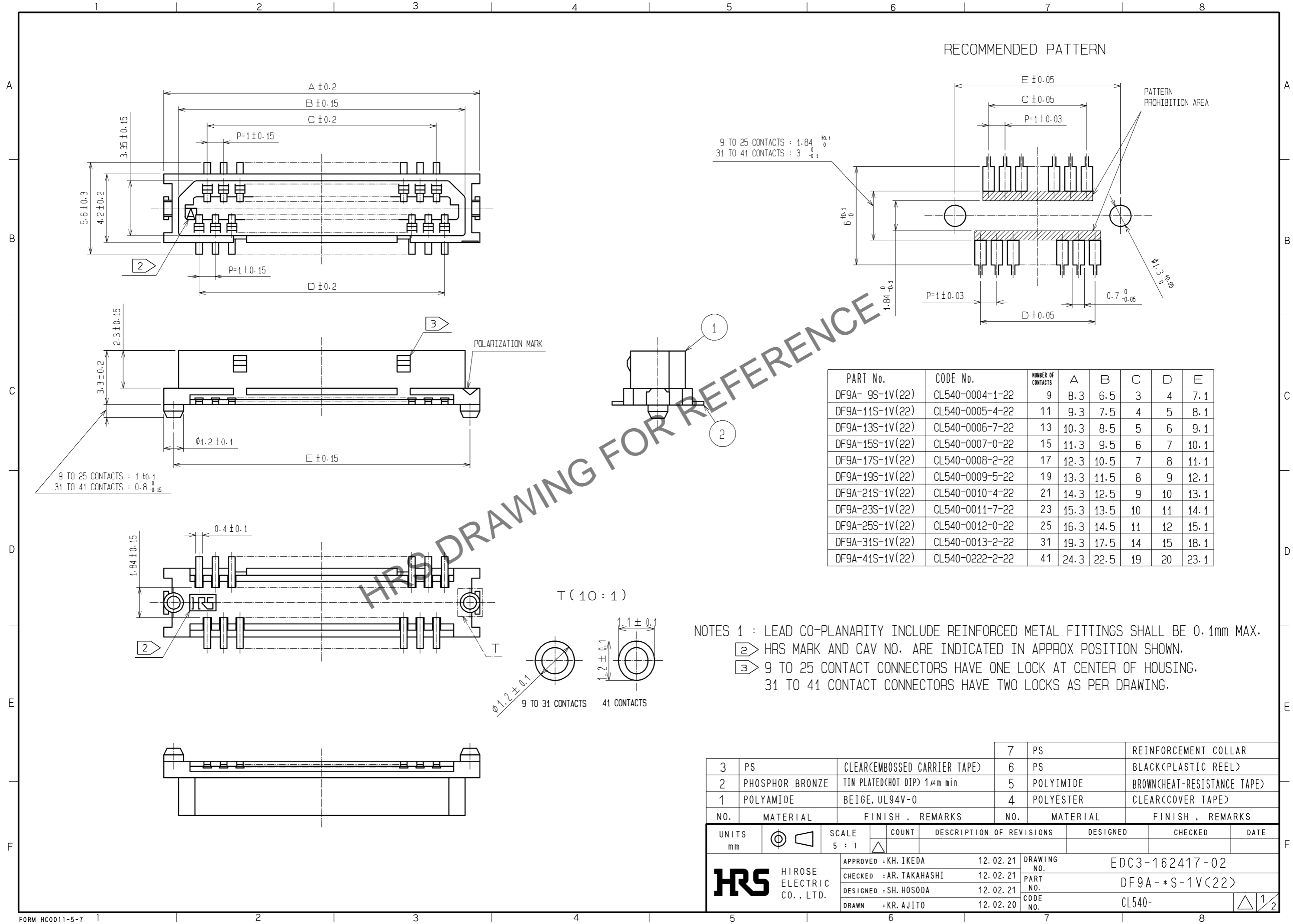

9 TO 25 CONTACTS :  $1.84^{+0.1}_0$   
 31 TO 41 CONTACTS :  $3^{-0.1}_0$

9 TO 25 CONTACTS :  $1^{+0.1}_0$   
 31 TO 41 CONTACTS :  $0.8^{-0.15}_0$

PART No.	CODE No.	NUMBER OF CONTACTS	A	B	C	D	E
DF9A-9S-1V(22)	CL540-0004-1-22	9	8.3	6.5	3	4	7.1
DF9A-11S-1V(22)	CL540-0005-4-22	11	9.3	7.5	4	5	8.1
DF9A-13S-1V(22)	CL540-0006-7-22	13	10.3	8.5	5	6	9.1
DF9A-15S-1V(22)	CL540-0007-0-22	15	11.3	9.5	6	7	10.1
DF9A-17S-1V(22)	CL540-0008-2-22	17	12.3	10.5	7	8	11.1
DF9A-19S-1V(22)	CL540-0009-5-22	19	13.3	11.5	8	9	12.1
DF9A-21S-1V(22)	CL540-0010-4-22	21	14.3	12.5	9	10	13.1
DF9A-23S-1V(22)	CL540-0011-7-22	23	15.3	13.5	10	11	14.1
DF9A-25S-1V(22)	CL540-0012-0-22	25	16.3	14.5	11	12	15.1
DF9A-31S-1V(22)	CL540-0013-2-22	31	19.3	17.5	14	15	18.1
DF9A-41S-1V(22)	CL540-0222-2-22	41	24.3	22.5	19	20	23.1

NOTES 1 : LEAD CO-PLANARITY INCLUDE REINFORCED METAL FITTINGS SHALL BE 0.1mm MAX.  
 ② HRS MARK AND CAV NO. ARE INDICATED IN APPROX POSITION SHOWN.  
 ③ 9 TO 25 CONTACT CONNECTORS HAVE ONE LOCK AT CENTER OF HOUSING.  
 31 TO 41 CONTACT CONNECTORS HAVE TWO LOCKS AS PER DRAWING.

NO.	MATERIAL	FINISH .	REMARKS	NO.	MATERIAL	FINISH .	REMARKS
3	PS		CLEAR(EMBOSSED CARRIER TAPE)	7	PS		REINFORCEMENT COLLAR
2	PHOSPHOR BRONZE		TIN PLATED(HOT DIP) 1μm min	6	PS		BLACK(PLASTIC REEL)
1	POLYAMIDE		BEIGE. UL94V-0	5	POLYIMIDE		BROWN(HEAT-RESISTANCE TAPE)
				4	POLYESTER		CLEAR(COVER TAPE)

  

UNITS	SCALE	COUNT	DESCRIPTION OF REVISIONS	DESIGNED	CHECKED	DATE
mm	5 : 1	△				

APPROVED : KH. IKEDA	12.02.21	DRAWING NO.	EDC3-162417-02
CHECKED : AR. TAKAHASHI	12.02.21	PART NO.	DF9A-*S-1V(22)
DESIGNED : SH. HOSODA	12.02.21	CODE NO.	CL540-
DRAWN : KR. AJITO	12.02.20		

Jun.1.2024 Copyright 2024 HIROSE ELECTRIC CO., LTD. All Rights Reserved.  
 In case of consideration for using Automotive equipment / device which demand high reliability, kindly contact our sales window correspondents.

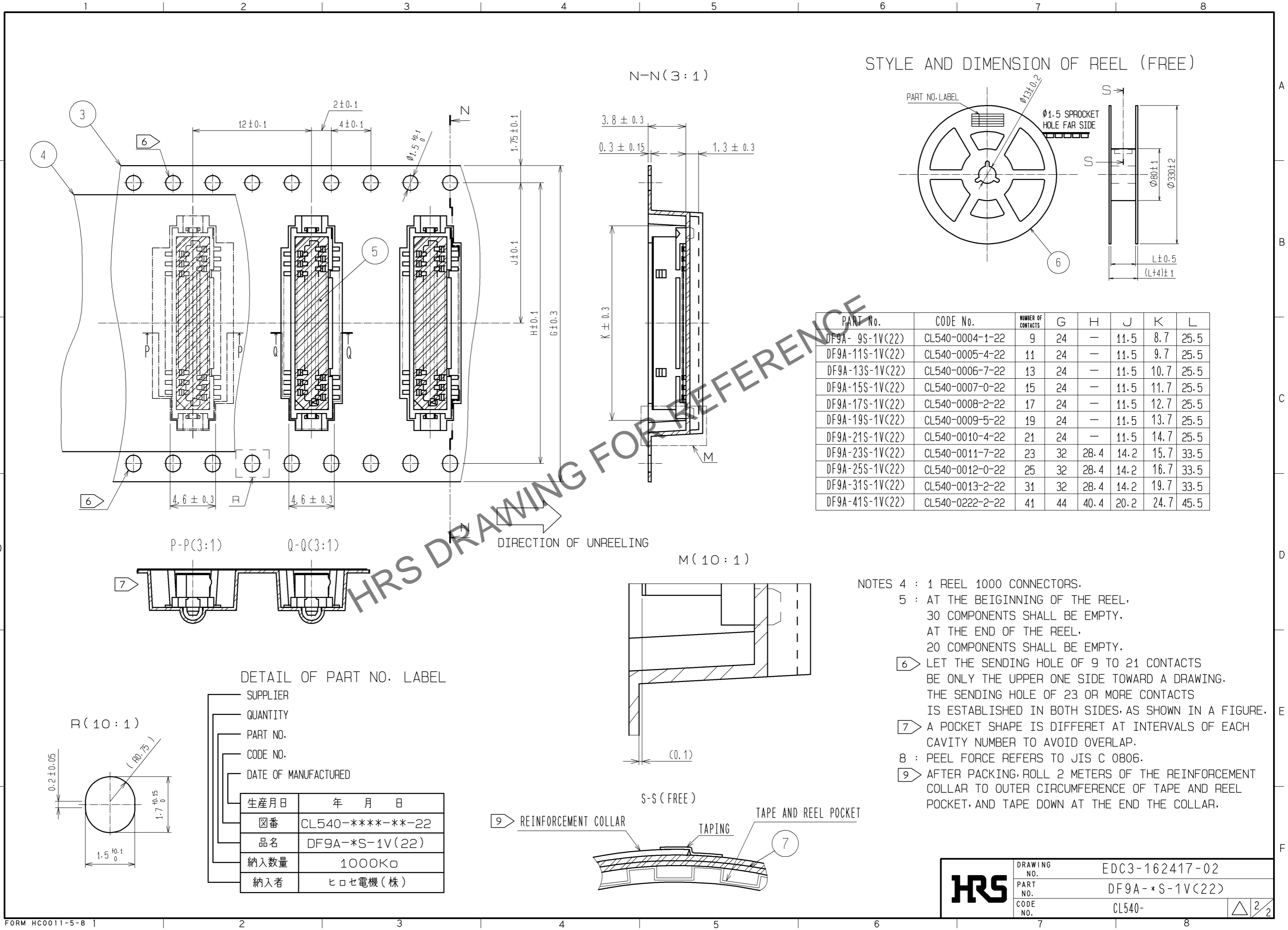

PART No.	CODE No.	NUMBER OF CONTACTS	G	H	J	K	L
DF9A-9S-1V(22)	CL540-0004-1-22	9	24	—	11.5	8.7	25.5
DF9A-11S-1V(22)	CL540-0005-4-22	11	24	—	11.5	9.7	25.5
DF9A-13S-1V(22)	CL540-0006-7-22	13	24	—	11.5	10.7	25.5
DF9A-15S-1V(22)	CL540-0007-0-22	15	24	—	11.5	11.7	25.5
DF9A-17S-1V(22)	CL540-0008-2-22	17	24	—	11.5	12.7	25.5
DF9A-19S-1V(22)	CL540-0009-5-22	19	24	—	11.5	13.7	25.5
DF9A-21S-1V(22)	CL540-0010-4-22	21	24	—	11.5	14.7	25.5
DF9A-23S-1V(22)	CL540-0011-7-22	23	32	28.4	14.2	15.7	33.5
DF9A-25S-1V(22)	CL540-0012-0-22	25	32	28.4	14.2	16.7	33.5
DF9A-31S-1V(22)	CL540-0013-2-22	31	32	28.4	14.2	19.7	33.5
DF9A-41S-1V(22)	CL540-0222-2-22	41	44	40.4	20.2	24.7	45.5

- NOTES
- 4 : 1 REEL 1000 CONNECTORS.
  - 5 : AT THE BEIGINING OF THE REEL, 30 COMPONENTS SHALL BE EMPTY. AT THE END OF THE REEL, 20 COMPONENTS SHALL BE EMPTY.
  - 6 : LET THE SENDING HOLE OF 9 TO 21 CONTACTS BE ONLY THE UPPER ONE SIDE TOWARD A DRAWING. THE SENDING HOLE OF 23 OR MORE CONTACTS IS ESTABLISHED IN BOTH SIDES, AS SHOWN IN A FIGURE.
  - 7 : A POCKET SHAPE IS DIFFERET AT INTERVALS OF EACH CAVITY NUMBER TO AVOID OVERLAP.
  - 8 : PEEL FORCE REFERS TO JIS C 0806.
  - 9 : AFTER PACKING, ROLL 2 METERS OF THE REINFORCEMENT COLLAR TO OUTER CIRCUMFERENCE OF TAPE AND REEL POCKET, AND TAPE DOWN AT THE END THE COLLAR.

DETAIL OF PART NO. LABEL

- SUPPLIER
- QUANTITY
- PART NO.
- CODE NO.
- DATE OF MANUFACTURED

生産月日	年 月 日
☒番	CL540-****-**-22
品名	DF9A-*S-1V(22)
納入数量	1000K口
納入者	ヒロセ電機(株)

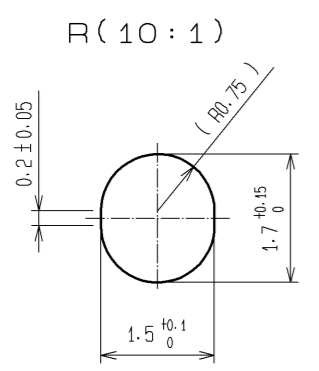

<b>HRS</b>	DRAWING NO.	EDC3-162417-02
	PART NO.	DF9A-*S-1V(22)
	CODE NO.	CL540-