

8	7	6	5
BASE PART NUMBER	THICKNESS	MATERIAL	STANDARD LENGTH PART NUMBER
0097-0540 (STANDARD)	0.069 ± 0.005 [0.0027]	BeCu ALLOY 25 TH01	0097054002
0098-0540 (ULTRASOFT)	0.051 ± 0.005 [0.0020]	BeCu ALLOY 25 TH01	0098054002

1	
PLATING CODE TABLE	
NUMBER CODE	PLATING TYPE
02	BRIGHT FINISH
17	BRIGHT TIN
19	BRIGHT NICKEL
MORE PLATING OPTIONS AVAILABLE CONTACT LAIRD SALES FOR DETAILS	

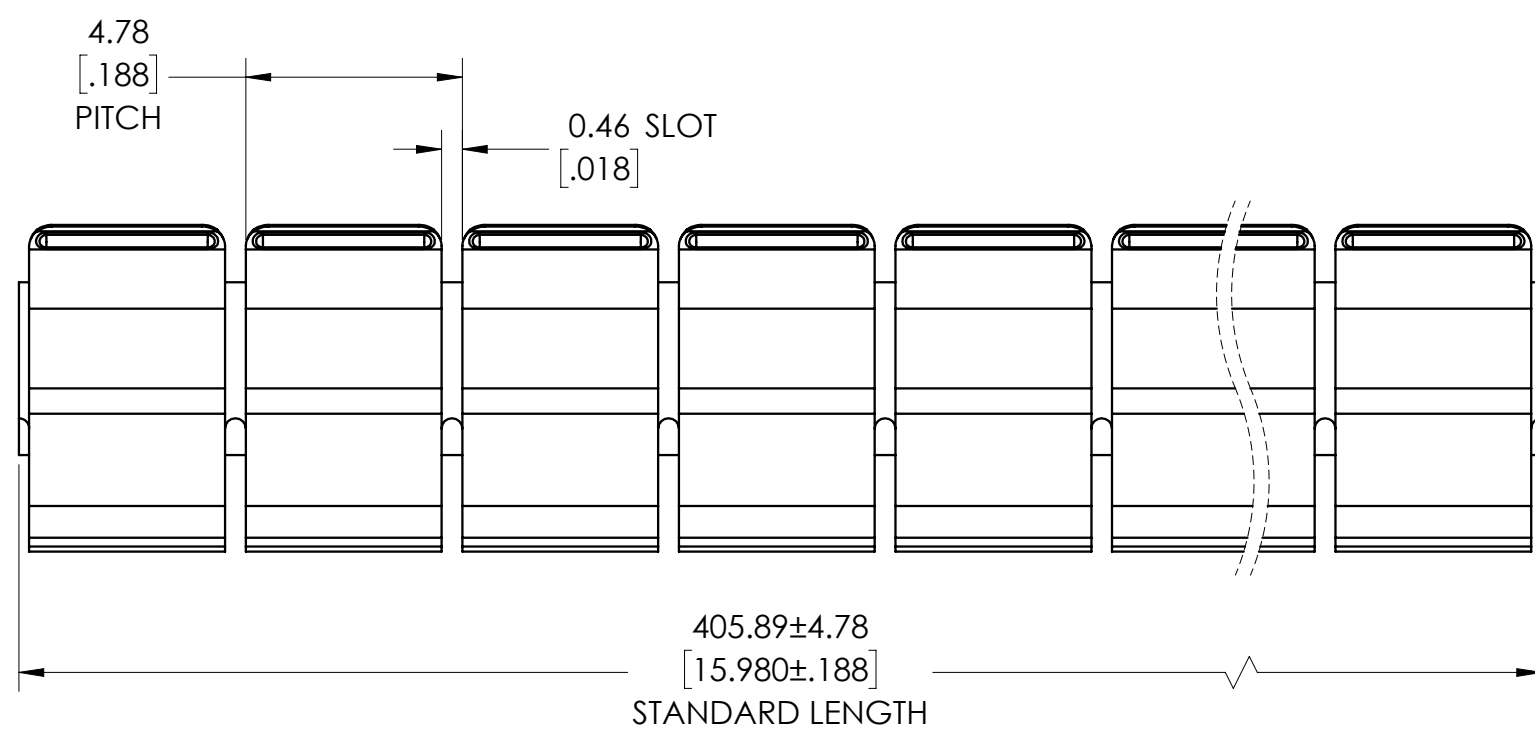

CUSTOM LENGTHS AVAILABLE IN MULTIPLES OF PITCHES OR "FINGERS"  
 LENGTH = PITCH X N  
 WHERE 'PITCH' IS 4.78 AND 'N' IS NUMBER OF PITCHES  
 EXAMPLE: 43 x 4.78 = 205.54MM LONG  
 SEE BOTTOM LEFT FOR CUSTOM LENGTH PART NUMBERING

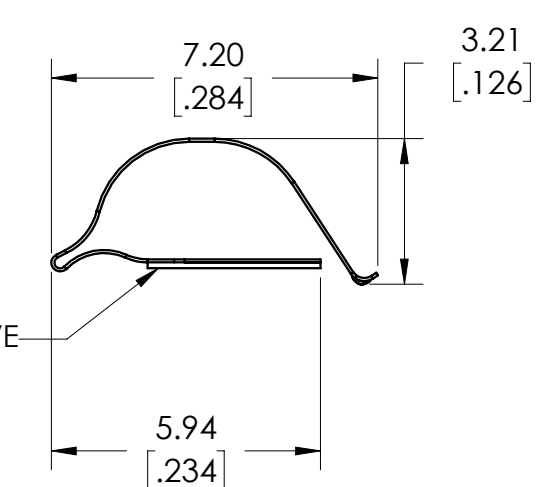
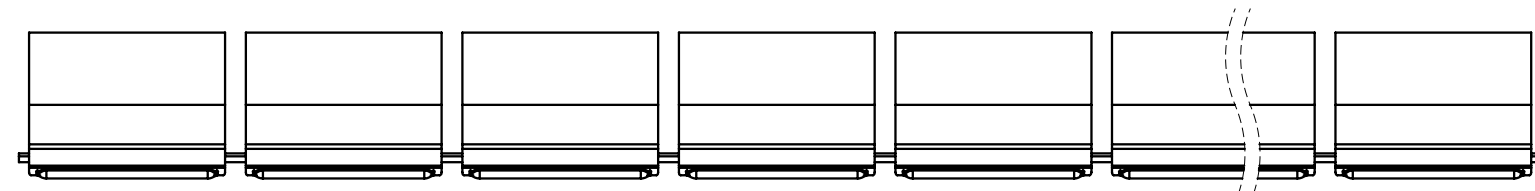

CUSTOM LENGTH PART NUMBER CONFIGURATION:  
 009X 0540 XX X OXXXX

7 FOR STANDARD  
 8 FOR ULTRASOFT

PLATING CODE (SEE TABLE)

LENGTH IN MM TO ONE DECIMAL PLACE

N FOR NO ADHESIVE  
 T FOR ADHESIVE

EXAMPLE: 0098054017N02055  
 ULTRASOFT, BRIGHT TIN PLATING, NO TAPE, 205.54MM LONG (43 FINGERS)

UNITS: MM [INCH]	<b>Laird</b>	LAIRD DRAWING NUMBER: <b>0097-0540-SALES</b>
TOLERANCES: X.X = ± 0.4 X.XX = ± 0.2 X.XXX = ± 0.1		THIS IS AN UNCONTROLLED SALES DRAWING. THE DIMENSIONAL CHARACTERISTICS AND TOLERANCES OF THIS PART SHOWN ON THIS DRAWING AS A REFERENCE TO THE DIMENSIONAL SPECIFICATIONS OF THE LAIRD STANDARD PRODUCTION DRAWING FOR THIS PART. ANY SUBSEQUENT CHANGES TO THE STANDARD PART SPECIFICATION WILL SUPERSEDE THIS SALES DRAWING.
ANGULAR: X° = ± 3° X.X° = ± 1.0°	3RD ANGLE PROJECTION DESIGNED IN SOLIDWORKS	SIZE <b>B</b>
	SCALE: 6:1	SHEET 1 OF 1