

REV.	ECN Number	Description	Drawn
1	CS21060023	RELEASE	Peak_2021.06.08

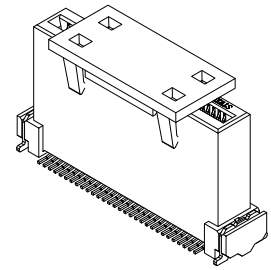

NOTES:
 1. MATERIAL:
 HOUSING & PAD : HIGH TEMPERATURE PLASTICS.
 CONTACT : COPPER ALLOY.
 CLIP : COPPER ALLOY.
 2. PRODUCT NUMBER MATRIX:

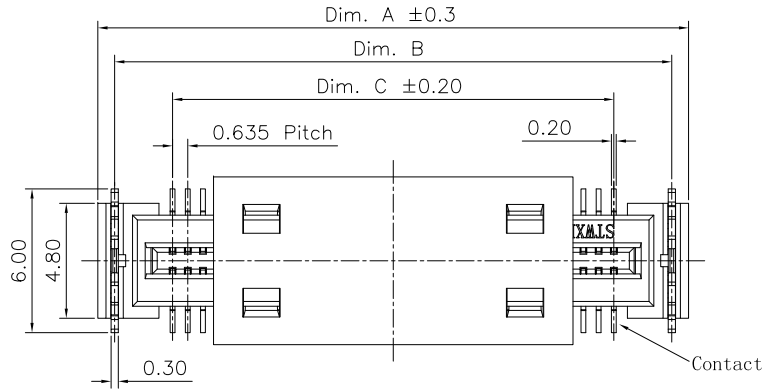
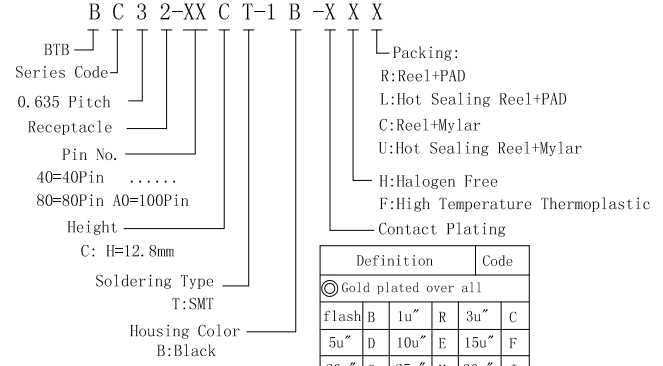

Definition	Code
◎ Gold plated over all	
flash B	1u" R 3u" C
5u" D	10u" E 15u" F
20u" G	25u" H 30u" J
◎ Duplex plated	
flash K	1u" S 3u" L
5u" M	10u" N 15u" P
20u" Q	25u" T 30u" U

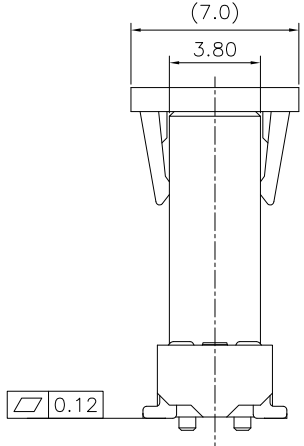
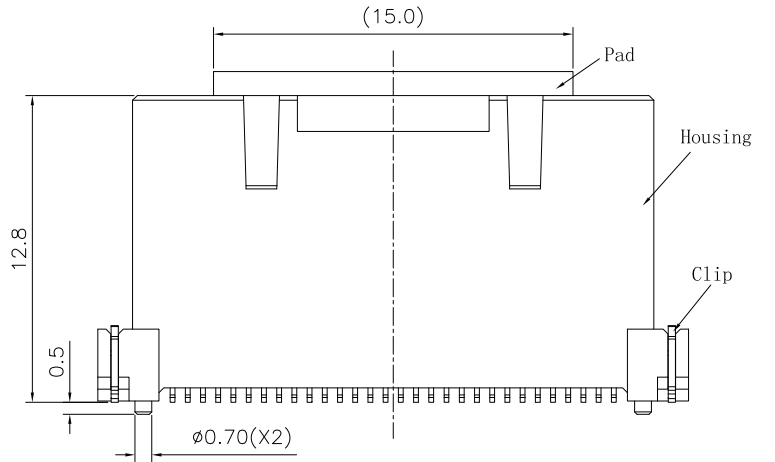

0.12

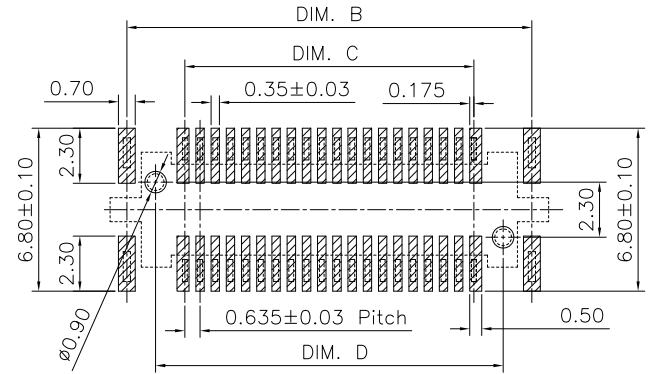
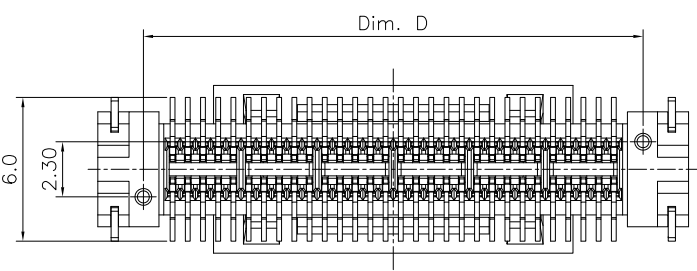

RECOMMENDED PCB LAYOUT TOLERANCE ±0.05

PIN NO.	DIM. A	DIM. B	DIM. C	DIM. D
40	18.30	16.90	12.065	14.50
60	24.65	23.25	18.415	20.85
80	31.00	29.60	24.765	27.20
100	37.35	35.95	31.115	33.55



TOLERANCE UNLESS OTHERWISE SPECIFIED			
X.X	±0.30	X.°	±3°
X.XX	±0.20	X.X°	±2°
X.XXX	±0.10	X.XX°	±1°

SCALE	1:1
UNIT	mm
SIZE	A4

ORIGINAL DRAWN: Peak
 CHECK: Xu peiguang
 APPROVE: Ady Zhou

DATE	2021.06.08
DATE	2021.06.08
DATE	2021.06.08

DWG. NO. 600-0000-0574
 PARTS NO. (INTENDED USE) BC32-XXCT-1B-XXX

TITLE 0.635Pitch Floating BTB Receptacle SMT

REV. 1
 SHEET 1/1