

PROTECTION PRODUCTS

Description

RClamp®0561Z is an ultra low capacitance ESD protection device specifically designed to protect high-speed differential lines. It offers desirable characteristics for board level protection including fast response time, low operating and clamping voltage, and no device degradation.

RClamp0561Z features extremely good ESD protection characteristics highlighted by low peak ESD clamping voltage, and high ESD withstand voltage (+/-12kV contact per IEC 61000-4-2). RClamp0561Z has a typical capacitance of 0.12pF allowing it to be used in high bandwidth applications such as HDMI 2.0 4K/2K, Thunderbolt, and USB 3.1. Each device will protect one high-speed data line operating up to 5.5 volts.

RClamp0561Z is in a 2-pin SGP0603P2X3 package measuring 0.62 x 0.32 mm with a nominal height of only 0.30mm. Leads are finished with NiAu. The small package gives the designer the flexibility to protect single lines in applications where arrays are not practical.

Nominal Dimensions

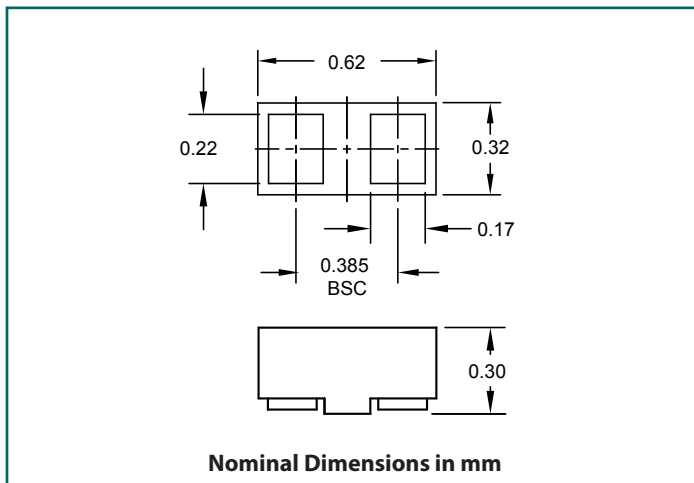

Features

- High ESD withstand voltage
 - ♦ IEC 61000-4-2 (ESD) 15kV (air), 12kV (contact)
- Ultra-Low capacitance: 0.12pF Typical
- Very small PCB area
- Protects one high-speed data line
- Working voltage: 5.5V
- Low reverse leakage current: 50nA max at $V_R=5.5V$
- Low Insertion Loss: 0.15dB (Typical) at 5GHz
- Large operating bandwidth: 17.5GHz
- Solid-state silicon-avalanche technology

Mechanical Characteristics

- SGP0603P2X3 Package
- Pb-Free, Halogen Free, RoHS/WEEE Compliant
- Nominal Dimensions: 0.62 x 0.32 x 0.30 mm
- Lead Finish: NiAu
- Marking : Marking Code
- Packaging : Tape and Reel

Applications

- HDMI 1.4 and HDMI 2.0
- USB 3.0 and USB 3.1
- USB Type-C
- Thunderbolt
- MIPI / MDDI
- 10GbE
- DVI

Schematic and Pin Configuration

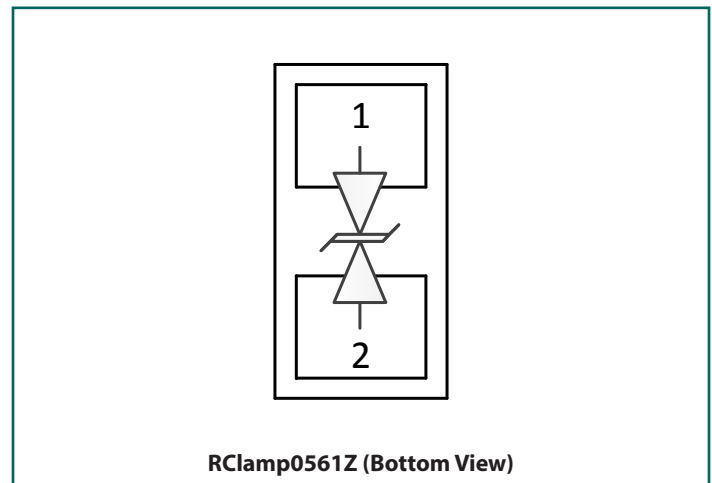

Absolute Maximum Ratings

Rating	Symbol	Value	Units
Peak Pulse Power (tp = 8/20μs)	P _{PK}	50	W
Peak Pulse Current (tp = 8/20μs)	I _{PP}	2.5	A
ESD per IEC 61000-4-2 (Air) ⁽¹⁾ ESD per IEC 61000-4-2 (Contact) ⁽¹⁾	V _{ESD}	±15 ±12	kV
Operating Temperature	T _J	-40 to +85	°C
Storage Temperature	T _{STG}	-55 to +150	°C

Electrical Characteristics (T=25°C unless otherwise specified)

Parameter	Symbol	Conditions	Min.	Typ.	Max.	Units
Reverse Stand-Off Voltage	V _{RWM}	-40°C to 85°C			5.5	V
Reverse Breakdown Voltage	V _{BR}	I _t = 1mA, -40°C to 85°C	6.5	9.5	10.5	V
Reverse Leakage Current	I _R	V _{RWM} = 5.5V	T = 25°C	0.1	50	nA
			T = 85°C	1	150	nA
Clamping Voltage	V _C	I _{PP} = 2A, tp = 8/20μs,		16.5	20	V
ESD Clamping Voltage ²	V _C	I _{PP} = 4A, tp = 0.2/100ns (TLP)		17		V
ESD Clamping Voltage ²	V _C	I _{PP} = 16A, tp = 0.2/100ns (TLP)		36		V
Dynamic Resistance ^{2,3}	R _{DYN}	tp = 0.2/100ns (TLP)		1.5		Ohms
Junction Capacitance	C _J	V _R = 0V, f = 1MHz, T = 25°C		0.12	0.15	pF
Cutoff Frequency	F _C	-3dB		17.5		GHz

Notes:

(1): Measured with a 40dB attenuator, 50 Ohm scope input impedance, 2GHz bandwidth. ESD gun return path connected to Ground Reference Plane (GRP)

(2): Transmission Line Pulse Test (TLP) Settings: tp = 100ns, tr = 0.2ns, I_{TLP} and V_{TLP} averaging window: t₁ = 70ns to t₂ = 90ns.

(3): Dynamic resistance calculated from I_{TLP} = 4A to I_{TLP} = 16A

Typical Characteristics

ESD Clamping (+8kV Contact per IEC 61000-4-2)

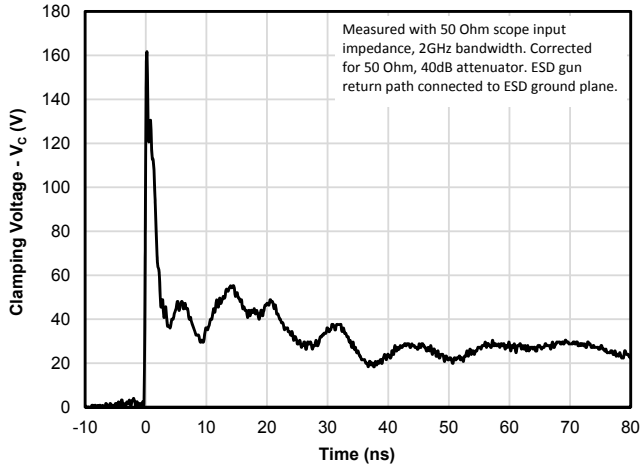

ESD Clamping (-8kV Contact per IEC 61000-4-2)

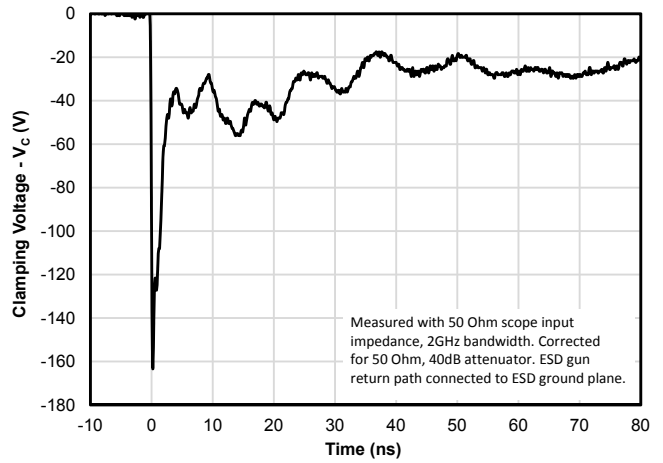

TLP IV Curve

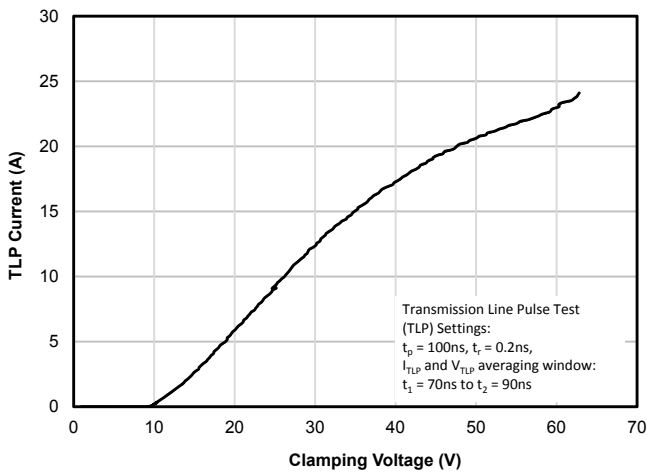

Insertion Loss (S21)

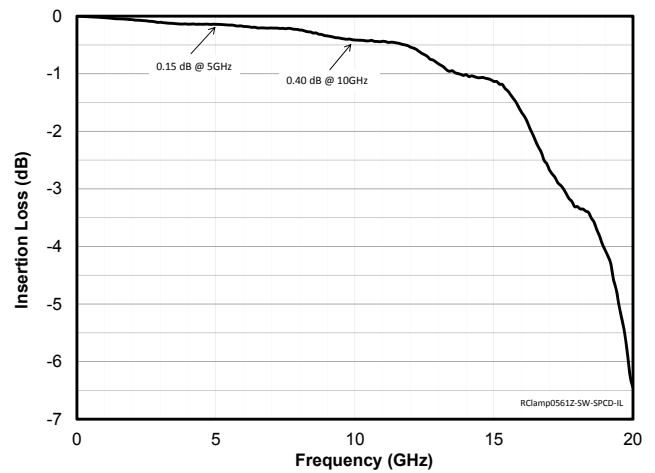

Capacitance vs. Reverse Voltage

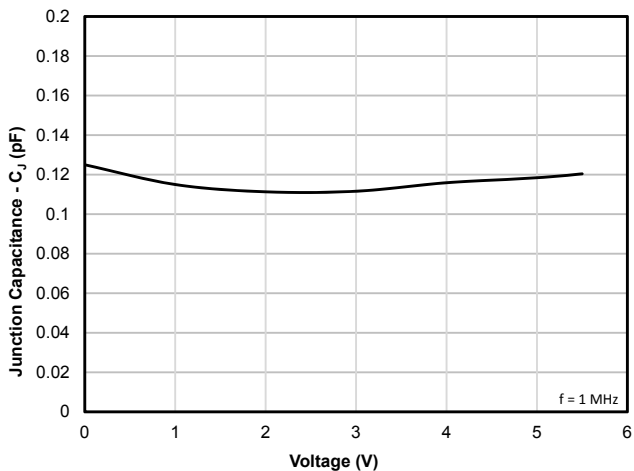

Capacitance vs. Temperature

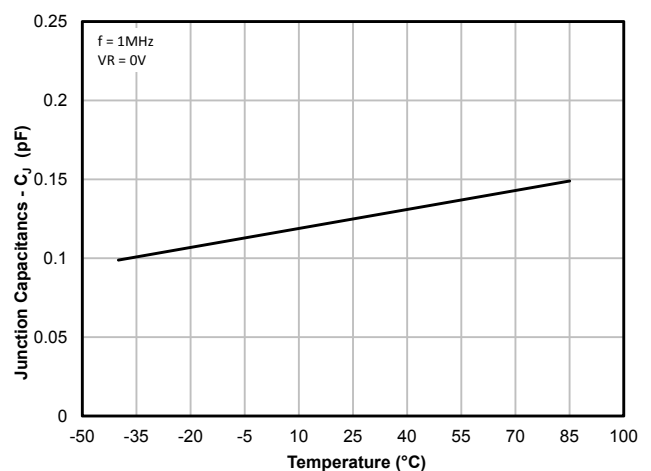

Typical Characteristics (Continued)

5Gb/s (USB 3.0) Eye Diagram with RClamp0561Z

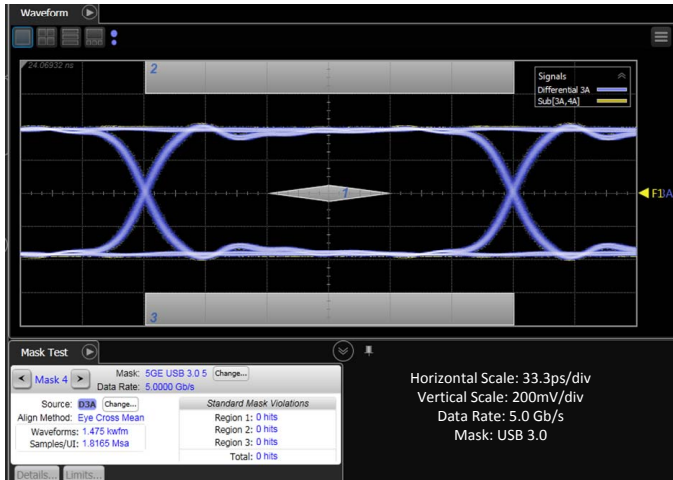

5Gb/s (USB 3.0) Eye Diagram without RClamp0561Z

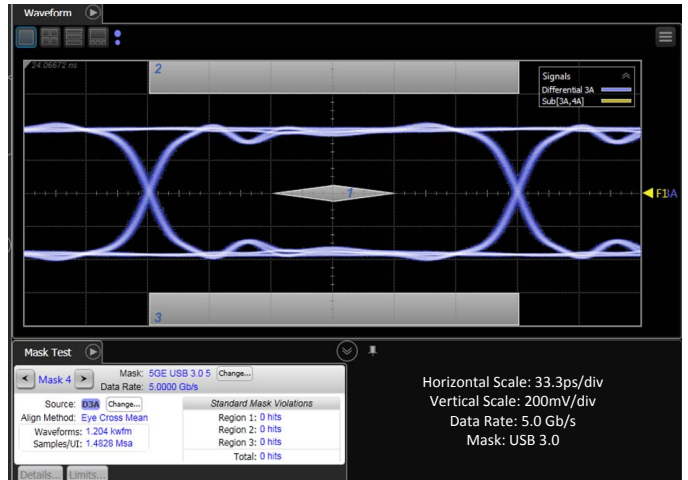

10Gb/s (USB 3.1) Eye Diagram with RClamp0561Z

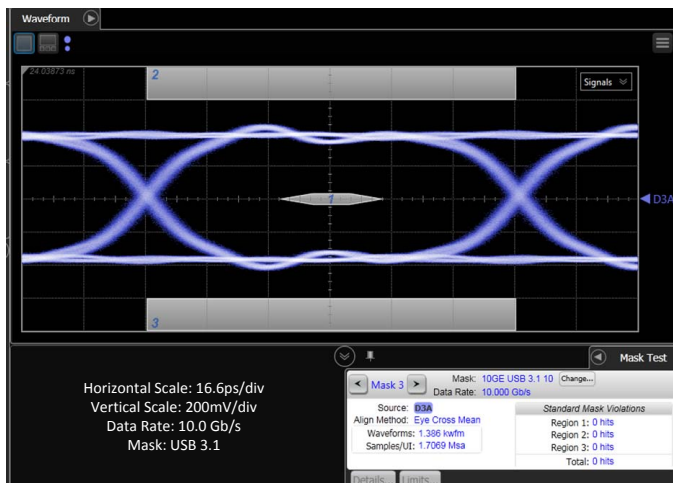

10Gb/s (USB 3.1) Eye Diagram without RClamp0561Z

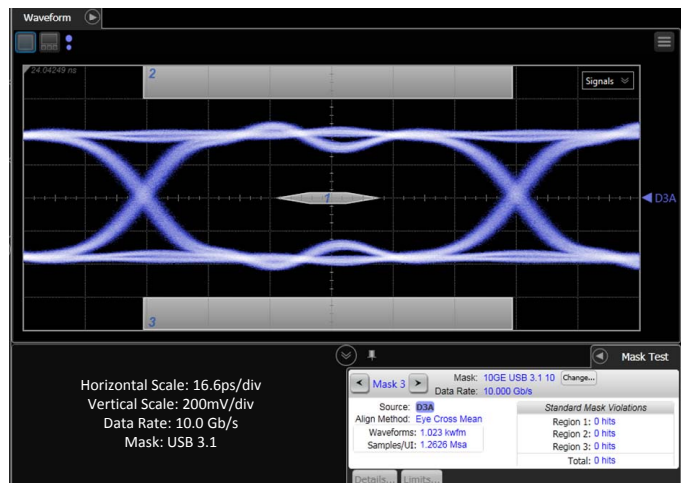

3.4Gb/s (HDMI) Eye Diagram with RClamp0561Z

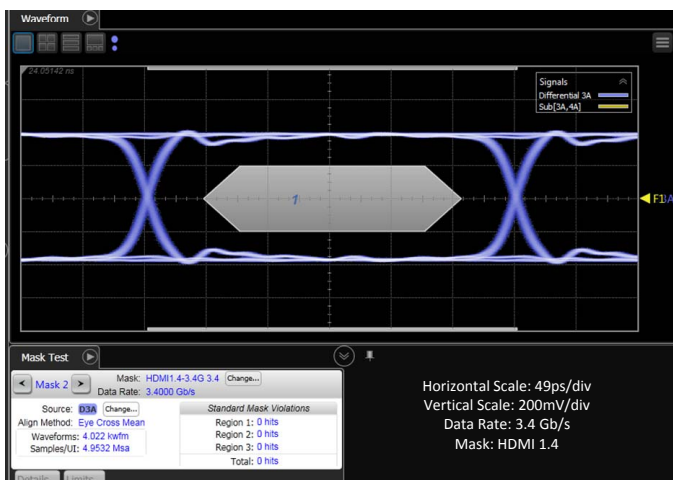

3.4Gb/s (HDMI) Eye Diagram without RClamp0561Z

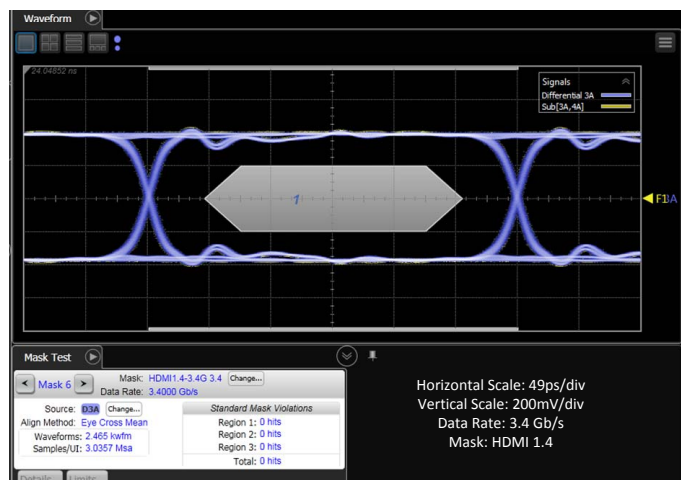

Typical Characteristics (Continued)

5.94Gb/s (HDMI 2.0) Eye Diagram with RClamp0561Z

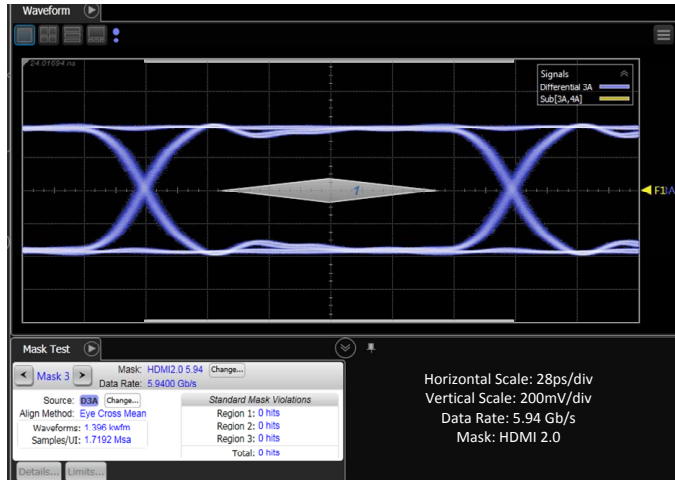

5.94Gb/s (HDMI 2.0) Eye Diagram without RClamp0561Z

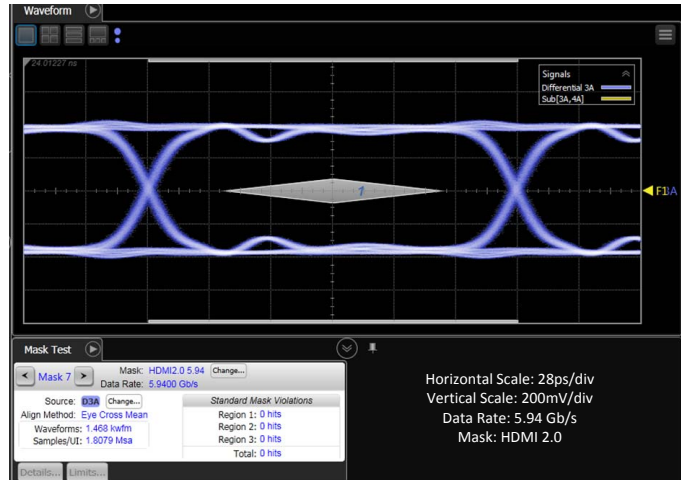

Application Information

USB Type-C Interface Protection

USB Type-C is a new 12-pin connector which supports USB 3.1 SuperSpeed+ (10Gb/s) connections and USB power delivery (USB PD). It is also backwards compatible (via an adaptor) with USB 3.0 and USB 2.0. The USB Type-C connector does not imply the use of USB 3.1 technology. USB Type-C is a connector shape. The underlying technology may be USB 2.0, USB 3.0, or USB 3.1. USB Type-C plugs are reversible (i.e. can be either be inserted right-side up or upside-down position) so there are connections on both the top and bottom of the PCB. The USB Type-C receptacle consists of 24-pins including: SuperSpeed RX and TX signal pairs, USB 2.0 DP and DM data pins, Auxiliary pins, Configuration pins, and Power and Ground Pins. Any of these connections are capable of conducting ESD current and should be protected.

Protection Solutions

SuperSpeed data line pairs are located on both the top and bottom of the PCB to support Type-C plug reversal (i.e. flip-ability). ESD protection of the SuperSpeed line pairs is achieved using one RClamp0561Z between each line and ground. A total of eight devices are required. The low capacitance of RClamp0561Z (0.15pF maximum) exhibits minimal effect on the transmission line impedance and excellent insertion loss characteristics (0.8dB loss at 10GHz). Single line devices make it easier for the designer to route the traces and maintain equal distance between the differential pairs for maximum signal integrity.

USB 2.0 pins support Type-C plug reversal by shorting

together the D+ pins and D- pins in the plug receptacle. This means protection components only need to be placed on the side of the PCB where the traces are routed. RClamp5011ZA is recommended for protection of these lines. Maximum capacitance is only 0.45pF. It also features very good ESD characteristics highlighted by an extremely low dynamic resistance of 0.25 Ohms. Likewise, these devices can be used to protect the configuration channel (CC) and Sideband (SBU) pins. VBus pins are connected together within the Type-C plug and bussed together on the PCB. USB Type-C default power is fixed at 5V. Single line devices such as uClamp0571P are recommended for surge and ESD protection. Note that in power delivery (PD) applications, higher working voltage TVS devices may be needed. Options exist for ESD and surge protection up to 24V.

Examples of USB Type-C ESD protection topology using single line protection devices are shown in Figures 1 and 2. A multi-line array such as RClamp7534P is an alternative solution for protecting the D+, D-, SBU, and CC pins.

Device Placement

Placement of the protection component is a critical element for effective ESD suppression. TVS diodes should be placed as close to the connector as possible. This helps reduce transient coupling to nearby traces. Ground connections should be made directly to the ground plane using micro-vias. This reduces parasitic inductance in the ground path and minimizes the clamping voltage seen by the protected device.

Figure 1 - USB Type-C Top Layer Protection Example

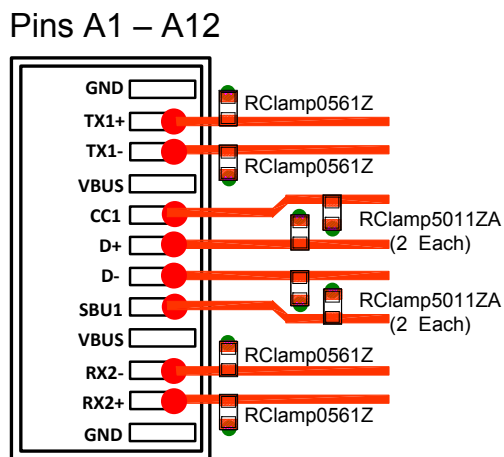
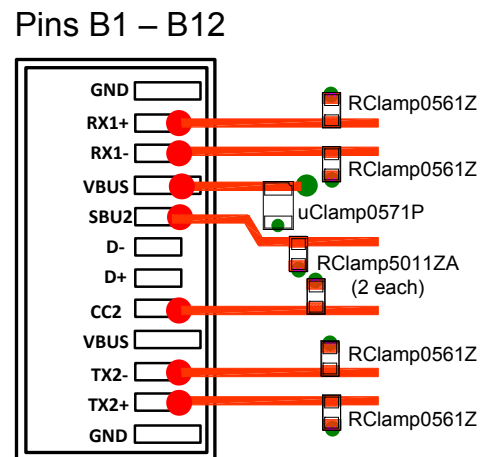

Figure 2 - USB Type-C Bottom Layer Protection Example



Applications Information

Assembly Guidelines

The small size of this device means that some care must be taken during the mounting process to insure reliable solder joints. The figure at the right details Semtech's recommended mounting pattern. Recommended assembly guidelines are shown in Table 1. Note that these are only recommendations and should serve only as a starting point for design since there are many factors that affect the assembly process. Exact manufacturing parameters will require some experimentation to get the desired solder application. Semtech's recommended mounting pattern is based on the following design guidelines:

Land Pattern

The recommended land pattern follows IPC standards and is designed for maximum solder coverage. Detailed dimensions are shown elsewhere in this document.

Solder Stencil

Stencil design is one of the key factors which will determine the volume of solder paste which is deposited onto the land pad. The area ratio of the stencil aperture will determine how well the stencil will print. The area ratio takes into account the aperture shape, aperture size, and stencil thickness. A minimum area ratio of 0.66 is preferred for the subject package. The area ratio of a rectangular aperture is given as:

$$\text{Area Ratio} = (L * W) / (2 * (L + W) * T)$$

Where:

L = Aperture Length

W = Aperture Width

T = Stencil Thickness

Semtech recommends a stencil with square aperture and rounded corners for consistent solder release. The stencil should be laser cut with electropolished finish. A stencil thickness of 0.075mm (0.003") is recommended. A 0.100mm (0.004") stencil may be used, however the stencil opening may need to be increased slightly to achieve the desired area ratio to ensure proper solder coverage on the pad.

Recommended Mounting Pattern

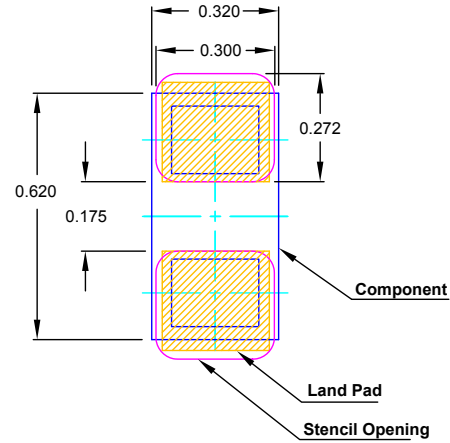

All Dimensions are in mm.

Land Pad. Stencil opening Component

Assembly Parameter	Recommendation
Solder Stencil Design	Laser Cut, Electro-Polished
Aperture Shape	Rectangular with Rounded Corners
Solder Stencil Thickness	0.075mm (0.003") or 0.100mm (0.004")
Solder Paste Type	Type 4 Size Sphere or Smaller
Solder Reflow Profile	Per JEDEC J-STD-020
PCB Solder Pad Design	Solder Mask Defined
PCB Pad Finish	OSP or NiAu

Outline Drawing - SGP0603P2X3

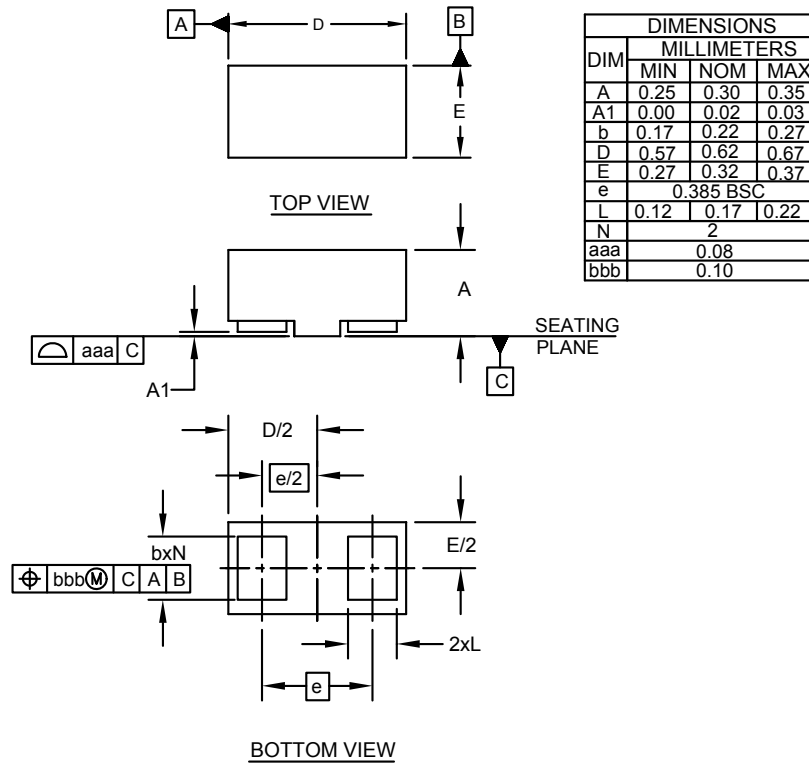

- NOTES:
1. CONTROLLING DIMENSIONS ARE IN MILLIMETERS (ANGLES IN DEGREES).

Land Pattern - SGP0603P2X3

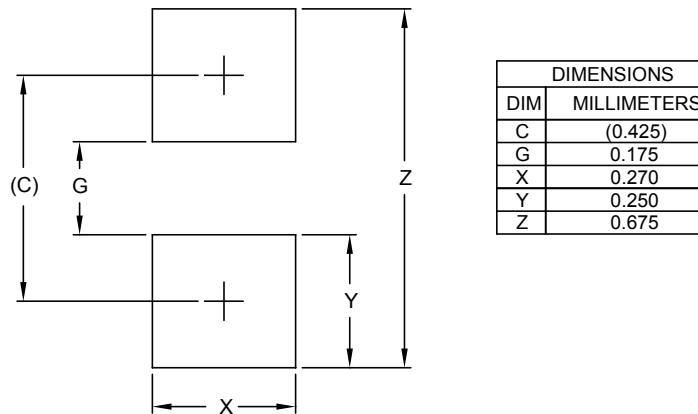

- NOTES:
1. CONTROLLING DIMENSIONS ARE IN MILLIMETERS (ANGLES IN DEGREES).
 2. THIS LAND PATTERN IS FOR REFERENCE PURPOSES ONLY. CONSULT YOUR MANUFACTURING GROUP TO ENSURE YOUR COMPANY'S MANUFACTURING GUIDELINES ARE MET.

Marking Code

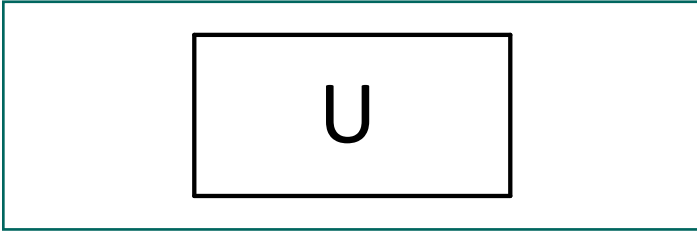

Notes: Device is electrically symmetrical

Tape and Reel Specification

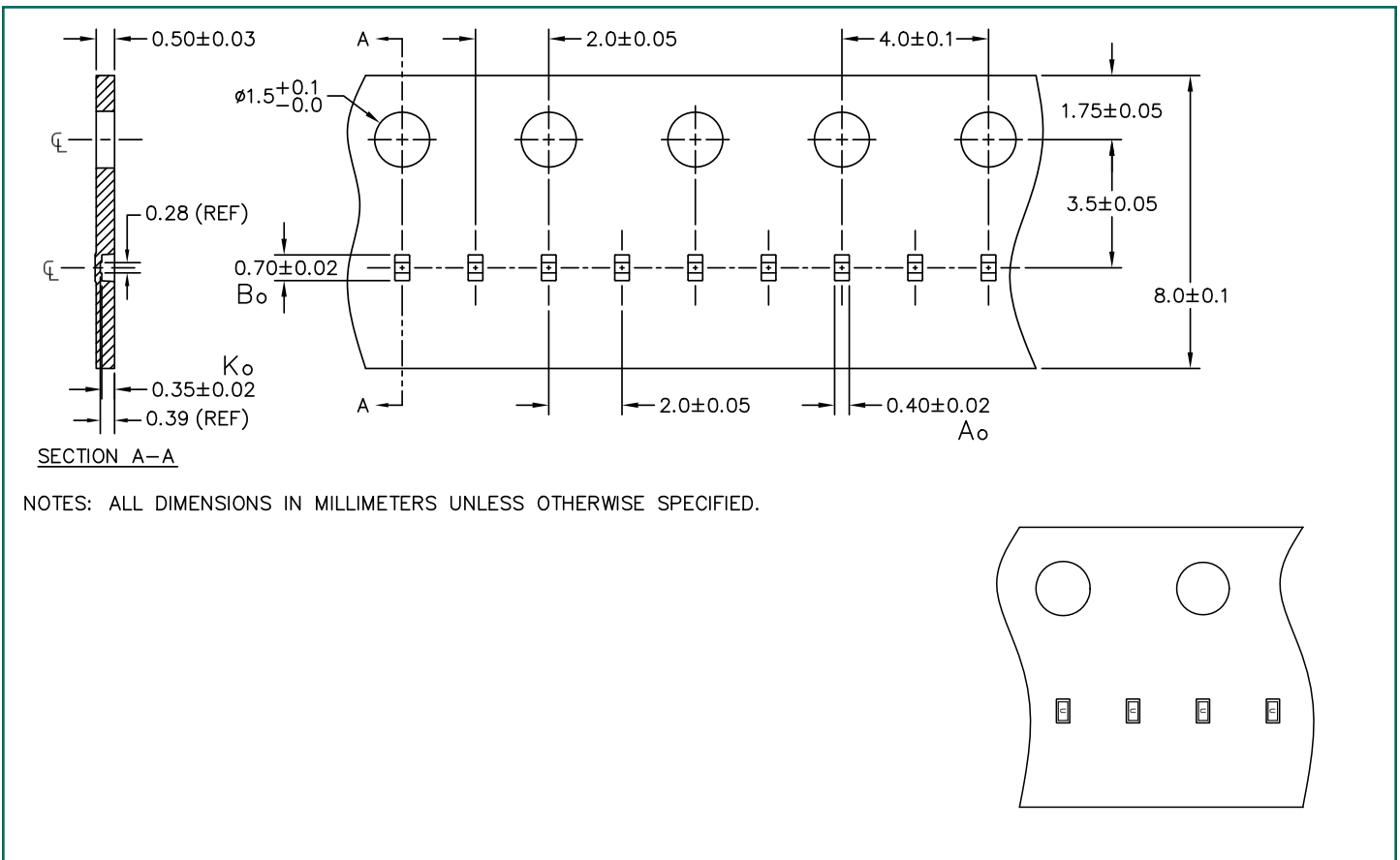

Ordering Information

Part Number	Qty per Reel	Reel Size	Tape Material
RClamp0561Z.TFT	15000	7 Inch	Paper
RailClamp and RClamp are registered trademarks of Semtech Corporation.			



IMPORTANT NOTICE

Information relating to this product and the application or design described herein is believed to be reliable, however such information is provided as a guide only and Semtech assumes no liability for any errors in this document, or for the application or design described herein. Semtech reserves the right to make changes to the product or this document at any time without notice. Buyers should obtain the latest relevant information before placing orders and should verify that such information is current and complete. Semtech warrants performance of its products to the specifications applicable at the time of sale, and all sales are made in accordance with Semtech's standard terms and conditions of sale.

SEMTECH PRODUCTS ARE NOT DESIGNED, INTENDED, AUTHORIZED OR WARRANTED TO BE SUITABLE FOR USE IN LIFE-SUPPORT APPLICATIONS, DEVICES OR SYSTEMS, OR IN NUCLEAR APPLICATIONS IN WHICH THE FAILURE COULD BE REASONABLY EXPECTED TO RESULT IN PERSONAL INJURY, LOSS OF LIFE OR SEVERE PROPERTY OR ENVIRONMENTAL DAMAGE. INCLUSION OF SEMTECH PRODUCTS IN SUCH APPLICATIONS IS UNDERSTOOD TO BE UNDERTAKEN SOLELY AT THE CUSTOMER'S OWN RISK. Should a customer purchase or use Semtech products for any such unauthorized application, the customer shall indemnify and hold Semtech and its officers, employees, subsidiaries, affiliates, and distributors harmless against all claims, costs damages and attorney fees which could arise.

The Semtech name and logo are registered trademarks of the Semtech Corporation. All other trademarks and trade names mentioned may be marks and names of Semtech or their respective companies. Semtech reserves the right to make changes to, or discontinue any products described in this document without further notice. Semtech makes no warranty, representation or guarantee, express or implied, regarding the suitability of its products for any particular purpose. All rights reserved.

© Semtech 2015

Contact Information

Semtech Corporation
200 Flynn Road, Camarillo, CA 93012
Phone: (805) 498-2111, Fax: (805) 498-3804
www.semtech.com