

Customer Information Sheet

DRAWING No.: M80-5L20842M7-03-334-01-314

SHEET 2 OF 2

IF IN DOUBT - ASK

©

NOT TO SCALE

THIRD ANGLE PROJECTION

ALL DIMENSIONS IN mm

SPECIFICATIONS:

MATERIAL:
 MOULDING: GLASS FILLED PPS, UL94V-0, BLACK
 SIGNAL CONTACT: PHOSPHOR BRONZE
 POWER CONTACT: COPPER ALLOY
 COAX CONTACT:
 BODY = COPPER ALLOY
 INNER CONTACT = PHOSPHOR BRONZE
 INSULATOR = PTFE
 BOARD-MOUNT JACKSCREW, SCREW: STAINLESS STEEL
FINISH:
 SIGNAL CONTACT:
 0.75µ GOLD ON CONTACT AREA,
 3µ 100% TIN OVER NICKEL ON TAILS
 POWER CONTACT: GOLD
 COAX CONTACT: BODY, INNER CONTACT = GOLD
ELECTRICAL:
 WORKING VOLTAGE = 800V AC/DC
 VOLTAGE PROOF = 1200V AC/DC
 INSULATION RESISTANCE = 100MΩ MIN
 SIGNAL CONTACT:
 CURRENT RATING AT 25°C = 3.0A MAX
 CURRENT RATING AT 85°C = 2.2A MAX
 CONTACT RESISTANCE = 25mΩ MAX
 POWER CONTACT:
 CONTACT RESISTANCE = 6mΩ MAX
 CURRENT RATING = 20A MAX
 COAX CONTACT:
 FREQUENCY RANGE = 6GHz
 IMPEDANCE = 50Ω
 V.S.W.R = 1.05 + (0.04 x FREQUENCY) GHz MAX
 CONTACT RESISTANCE = 6mΩ MAX
 INSULATION RESISTANCE = 10⁶MΩ @250V AC
 OPERATING VOLTAGE = 180V AC @ 500mA
 MAXIMUM VOLTAGE = 1000V AC
MECHANICAL:
 DURABILITY = 500 OPERATIONS
 SIGNAL CONTACT:
 INSERTION FORCE = 2.0N MAX
 WITHDRAWAL FORCE = 0.2N MIN
 POWER CONTACT:
 INSERTION FORCE = 8N MAX
 WITHDRAWAL FORCE = 0.5N MIN
 COAX CONTACT:
 INSERTION FORCE = 8N MAX
 WITHDRAWAL FORCE = 0.5N MIN
ENVIRONMENTAL:
 TEMPERATURE RANGE = -55°C TO +125°C
PACKING:
 TRAY
 FOR COMPLETE SPECIFICATION SEE COMPONENT SPECIFICATION C005XX (LATEST ISSUE)

NOTES:
 1. CONNECTORS ARE SUPPLIED WITH SCREWS LOOSE.

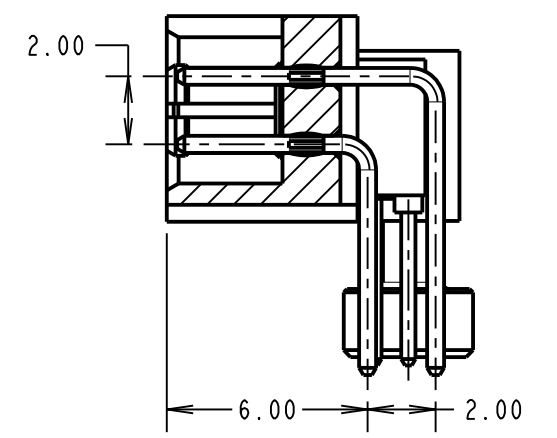
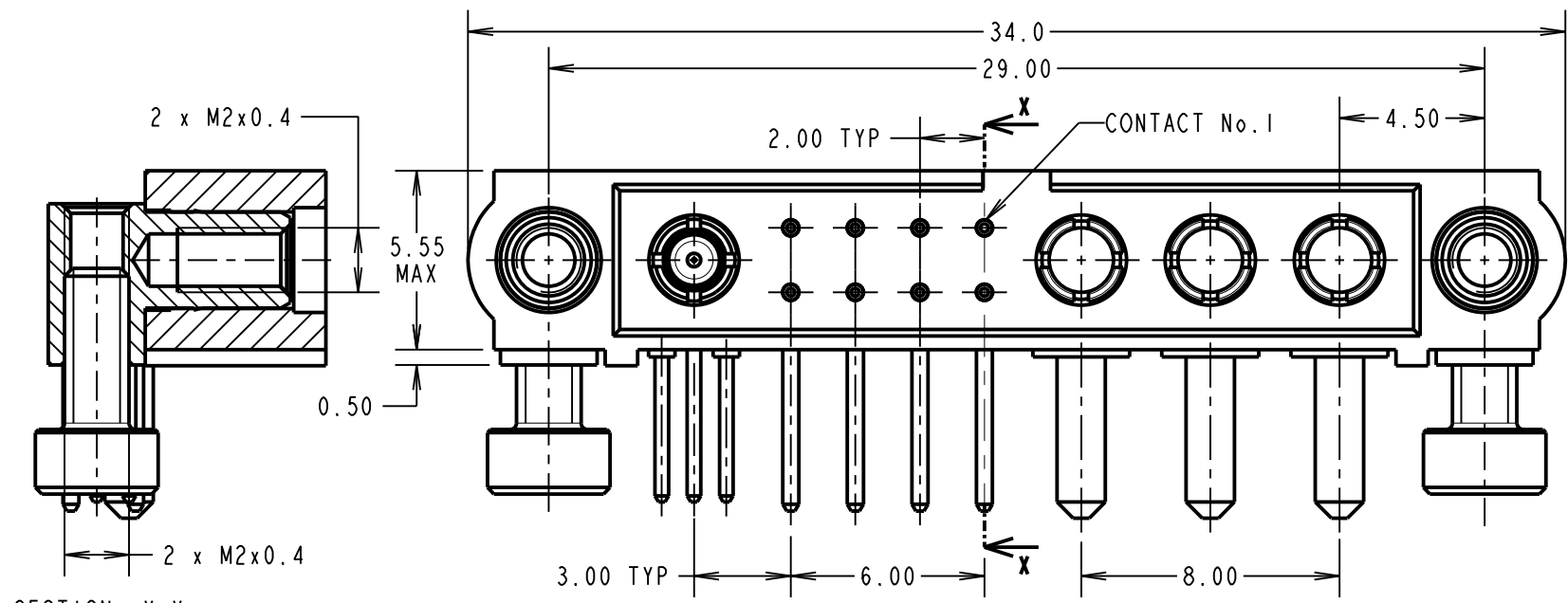

SECTION X-X

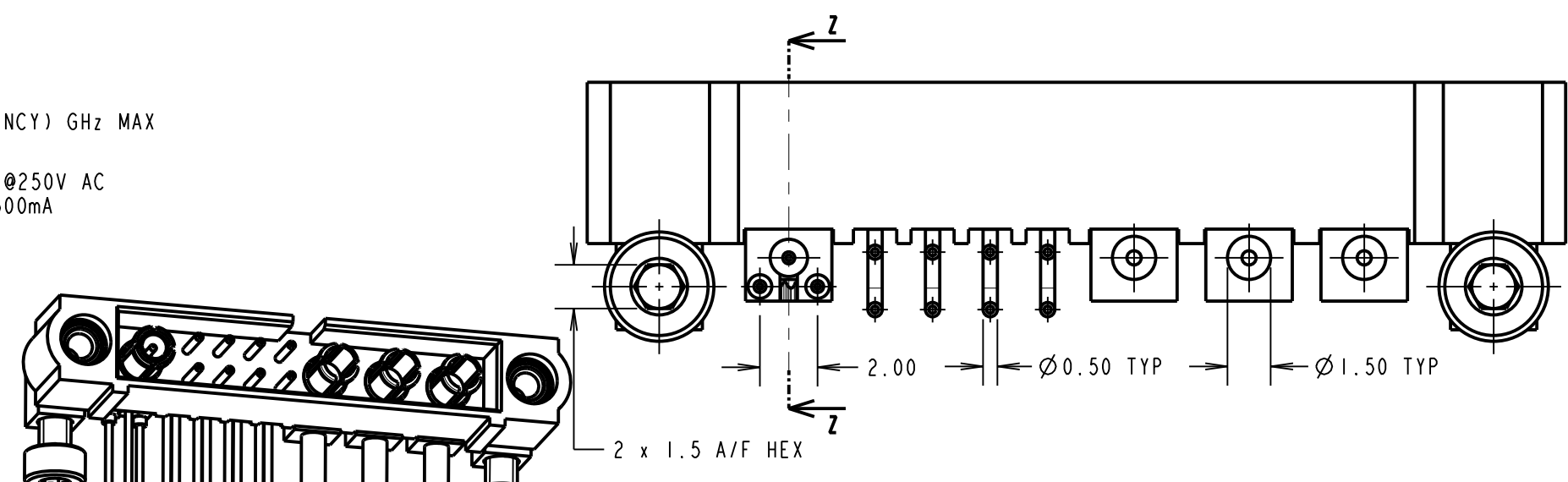

SECTION Z-Z

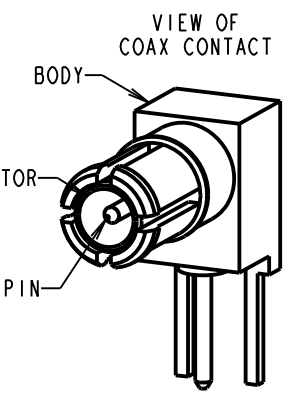
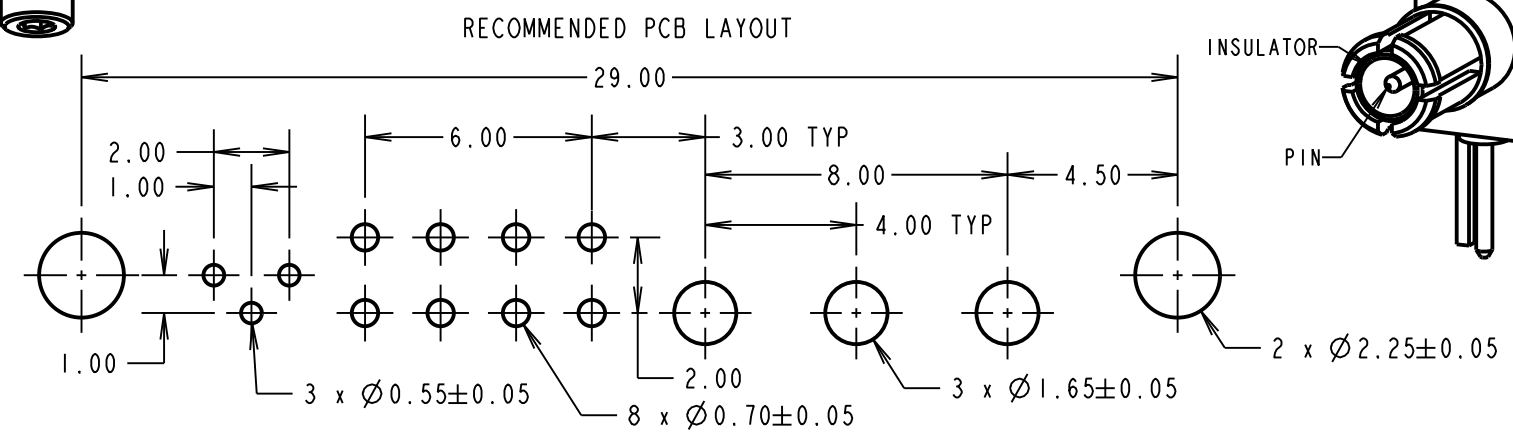
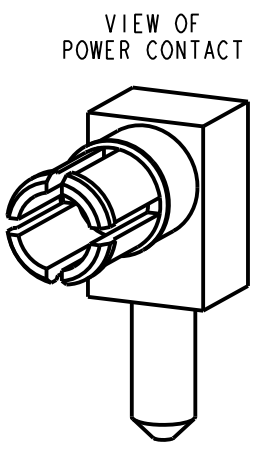
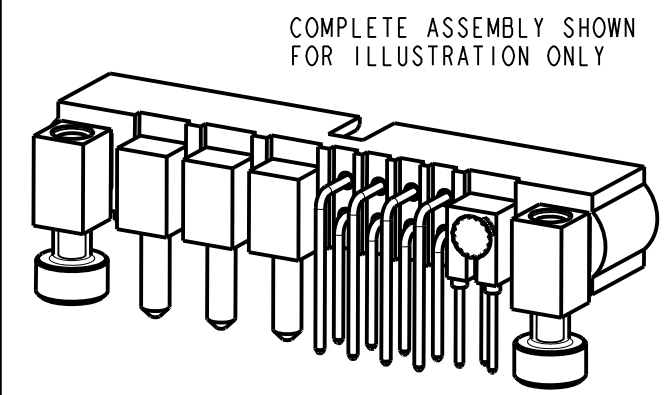

LS	2	25.10.17	13269
NAME	ISS.	DATE	C/NOTE
APPROVED: LS			
CHECKED: MGP			
DRAWN: R. ADDE			
CUSTOMER REF.:			
ASSEMBLY DRG:			

 www.harwin.com technical@harwin.com	THIS DRAWING AND ANY INFORMATION OR DESCRIPTIVE MATTER SET OUT HEREON ARE CONFIDENTIAL AND COPYRIGHT PROPERTY OF THE HARWIN GROUP AND MUST NOT BE DISCLOSED, LOANED, COPIED OR USED FOR MANUFACTURING, TENDERING OR FOR ANY OTHER PURPOSE WITHOUT THEIR WRITTEN PERMISSION.	TOLERANCES X. = ±1mm X.X = ±0.50mm X.XX = ±0.10mm X.XXX = ±0.01mm ANGLES = ±5° UNLESS STATED	MATERIAL: SEE ABOVE FINISH: SEE ABOVE S/AREA: mm ²	TITLE: JACKSCREW DATAMATE MIXED TECHNOLOGY HORIZONTAL PC TAIL MALE ASSEMBLY DRAWING NUMBER: M80-5L20842M7-03-334-01-314	SHT 2 OF 2
---	---	--	--	--	---------------