

REVISIONS		REVISION DATE	APPR
SYM	DESCRIPTION		

FULL SECTION

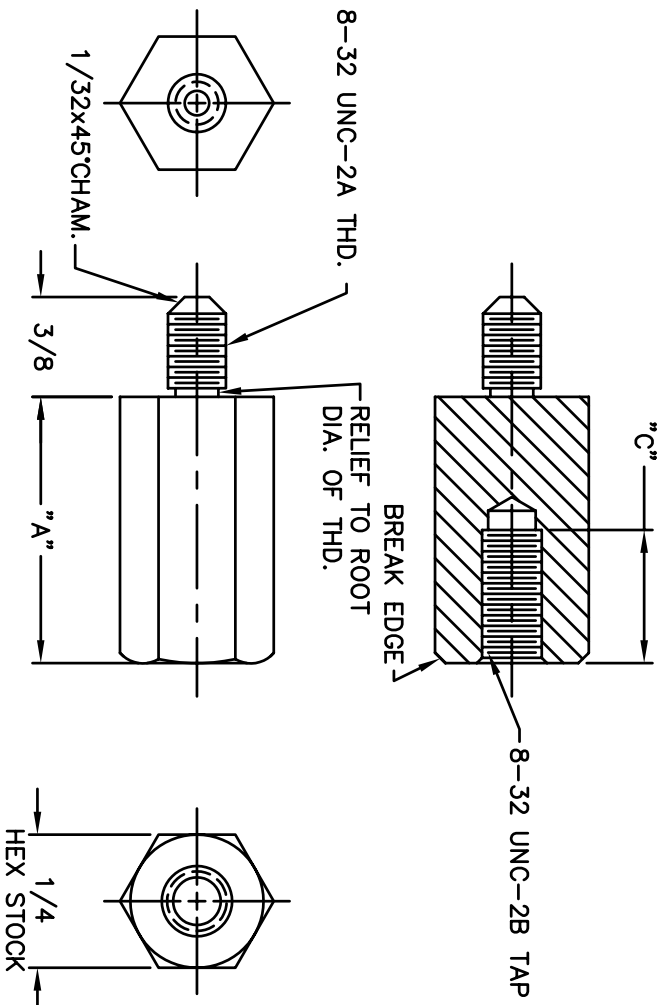

STANDOFF		
PART NO.	LENGTH	"C" NO. THDS
8280	.250	3-4
8281	.375	6-7
8282	.500	10-11
8283	.625	12-13
8284	.750	12-13
8285	.875	12-13
8286	1.000	12-13
8287	1.125	12-13
8288	1.250	12-13
8289	1.375	12-13
8290	1.500	12-13
8291	1.625	12-13
8292	1.750	12-13
8293	2.000	12-13
8294	2.500	12-13
8295	3.000	12-13

MATERIAL: BRASS-ALLOY 360-1/2 HARD		FINISH: NICKEL
DIMENSIONAL TOLERANCES UNLESS OTHERWISE SPECIFIED		TITLE: 8280-8295
XX	XXX	XXXX
---	---	---
FRACTIONS	ANGLES	SCALE
---	---	4X
HEAT TREAT:	---	---
PLOT SCALE:	1=1	---
DRAWN: T. LORD	DATE: 01/7/03	SIZE: B
CHECKED: T. LORD	DATE: 01/7/03	DRAWING NUMBER: SD: 8280-8295
APPROVED: T. LORD	DATE: 01/7/03	ISSUE: F

ABBATRON
 Electronic Connectors and Hardware
 13680 S. MOSERTOWN RD
 MEADVILLE, PA 16335