

IGBT

Features/特性

- 1200V, 15A
- $V_{CE(sat)}(typ.)=2.0V @V_{GE}=15V, I_C=15A$
- 具有正温度系数的 $V_{CE(sat)}$
 $V_{CE(sat)}$ with positive temperature coefficient
- 包括快速软恢复反并联前馈
Including fast & soft recovery anti-parallel FWD
- 快开关速度
High speed switching

Applications/应用

- 不间断电源
Uninterruptible power supply
- 电机驱动逆变器
Inverter for motor drive
- 交、直流伺服驱动放大器
AC and DC servo drive amplifier

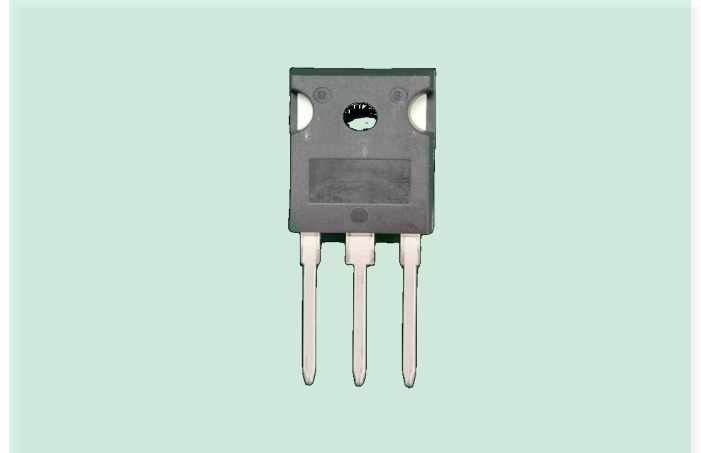

Equivalent Circuit Schematic/等效电路图

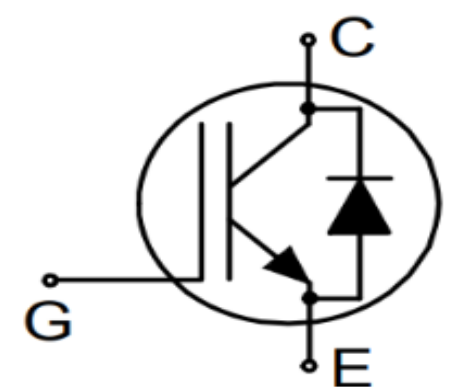

IGBT-Absolute Maximum Ratings (@ $T_C = 25^\circ\text{C}$ unless otherwise specified)

Symbol	Parameter	Value	Units
V_{CES}	Collector-Emitter Voltage 集电极-发射极电压	1200	V
V_{GES}	Gate-Emitter Peak Voltage 栅极-发射极峰值电压	± 30	V
I_C	DC collector current, limited by T_{vjmax} 集电极直流电流受最大结温限制	$T_C = 100^\circ\text{C}$ 15	A
I_{CM}	Pulsed collector current, tp limited by T_{vjmax} 集电极脉冲电流脉宽受最大结温限制	45	A
P_{tot}	Maximum Power Dissipation 最大耗散功率	$T_C = 25^\circ\text{C}$ 108	W
		$T_C = 100^\circ\text{C}$ 43	W

IGBT Characteristics (@ $T_C = 25^\circ\text{C}$ unless otherwise specified)

Symbol	Parameter	Conditions	Min.	Typ.	Max.	Unit	
$V_{CE\ sat}$	Collector to Emitter Saturation Voltage 集电极-发射极饱和电压	$I_C = 15\text{ A}, V_{GE} = 15\text{ V}$		2.0	2.5	V	
$V_{GE\ th}$	Gate-Emitter Threshold Voltage 栅极阈值电压	$I_C = 250\ \mu\text{A}, V_{CE} = V_{GE}$	4.5	5.2	6.5	V	
I_{CES}	Collector-Emitter Cut-off Current 集电极-发射极截止电流	$V_{CE} = 1200\text{ V}, V_{GE} = 0\text{ V}, T_{vj} = 25^\circ\text{C}$			100.0	μA	
I_{GES}	Gate-emitter Leakage Current 栅极-发射极漏电流	$V_{CE} = 0\text{ V}, V_{GE} = \pm 30\text{ V}, T_{vj} = 25^\circ\text{C}$			± 100	nA	
Q_G	Gate Charge 栅极电荷	$V_{CC}=600\text{V}, I_C=15\text{A}$ $V_{GE}=15\text{V}$		120		nC	
Q_{GE}	Gate-Emitter Charge 栅极-发射极电荷			50		nC	
Q_{GC}	Gate-Collector Charge 栅极-集电极电荷			15		nC	
C_{ies}	Input Capacitance 输入电容	$V_{CE}=25\text{V}, f=1\text{MHz},$ $V_{GE}=0\text{V}$		2450		nF	
C_{oies}	Output Capacitance 输出电容			95		nF	
C_{res}	Reverse Transfer Capacitance 反向传输电容			45		nF	
t_{don}	Turn-on Delay Time 开通延迟时间	$V_{CE}=600\text{V}, I_C=15\text{A},$ $R_G=15\Omega, V_{GE}=15\text{V}$		37		nS	
t_r	Rise Time 上升时间			74		nS	
t_{doff}	Turn-off Delay Time 关断延迟时间			83		nS	
t_f	Fall Time 下降时间			93		nS	
E_{on}	Turn-On Switching Loss Per Pulse 开通损耗能量				1.24		mJ
E_{off}	Turn-off Energy Loss Per Pulse 关断损耗能量				0.48		mJ

Diode-Absolute Maximum Ratings (@ $T_C = 25^\circ\text{C}$ unless otherwise specified)

Symbol	Parameter	Value	Units
V_{RRM}	Repetitive Peak Reverse Voltage 反向重复峰值电压	1200	V
I_F	Diode Continuous Forward Current 连续正向直流电流	$T_C = 100^\circ\text{C}$ 15	A
I_{FM}	Diode maximum current, tp limited by T_{vjmax} 二极管最大电流, 脉宽受最大结温限制	45	A

Diode Characteristics (@ $T_C = 25^\circ\text{C}$ unless otherwise specified)

Symbol	Parameter	Conditions	Min.	Typ.	Max.	Unit
V_F	Diode Forward Voltage 正向电压	$I_F = 15\text{ A}$		2.1	3.5	V
Q_{rr}	Recovered Charge 恢复电荷	$I_F = 15\text{ A}, V_{CE} = 600\text{ V},$ $R_G = 15\ \Omega$		470		nC
I_{rr}	Peak Reverse Recovery Current 反向恢复峰值电流			15		A
t_{rr}	Reverse Recovery Time 反向恢复时间			62		nS

Thermal Characteristics

Symbol	Parameter	Min.	Typ.	Max.	Unit
R_{thJC}	Thermal resistance, junction to case for IGBT IGBT 结-外壳热阻			1.2	$^\circ\text{C}/\text{W}$
R_{thJC}	Thermal resistance, junction to case for Diode 二极管 结-外壳热阻			1.5	$^\circ\text{C}/\text{W}$
R_{thJA}	Thermal resistance, junction to Ambient 结-环境热阻			40	$^\circ\text{C}/\text{W}$

输出特性IGBT

Typical output characteristic IGBT

$$I_C = f(V_{CE})$$

$T_{vj} = 25^\circ\text{C}$

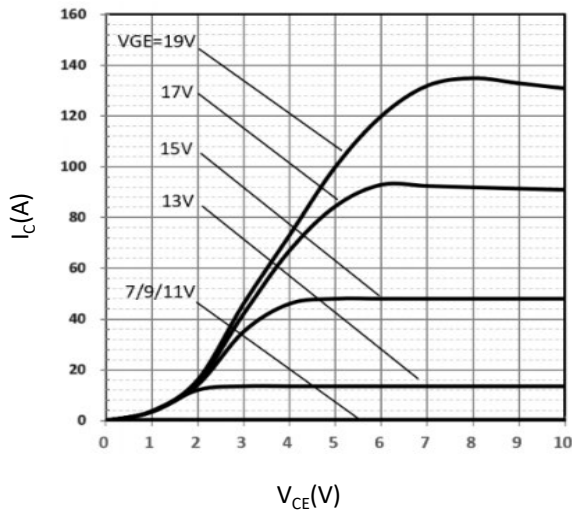

传输特性IGBT

Typical transfer characteristic IGBT

$$I_C = f(V_{GE})$$

$T_{vj} = 25^\circ\text{C}$

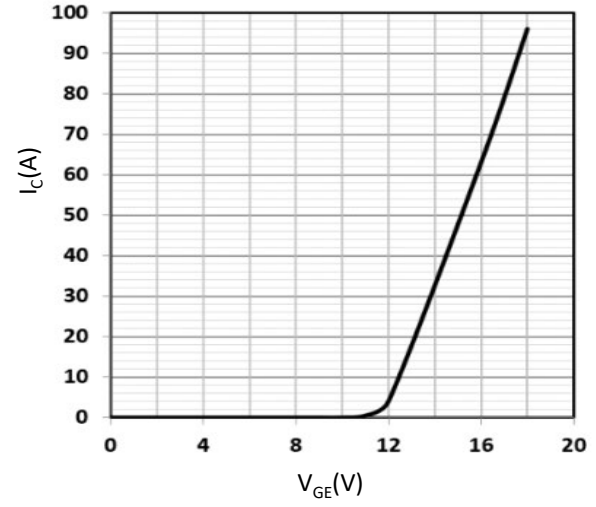

开关损耗IGBT

output characteristic IGBT

$$E_{on} = f(R_G), E_{off} = f(R_G)$$

$V_{GE}=15V, I_C=15A, V_{CE}=600V$

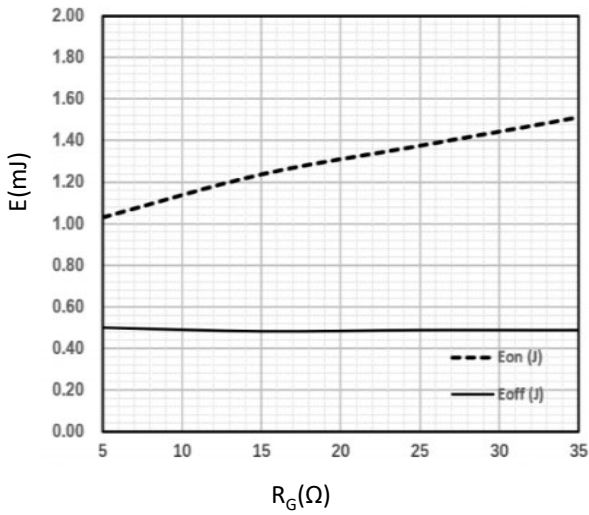

电容

capacitance as a function of collector-emitter voltage IGBT

$$C = f(V_{CE}), f = 1\text{MHz}, V_{GE} = 0\text{V}$$

$T_{vj} = 25^\circ\text{C}$

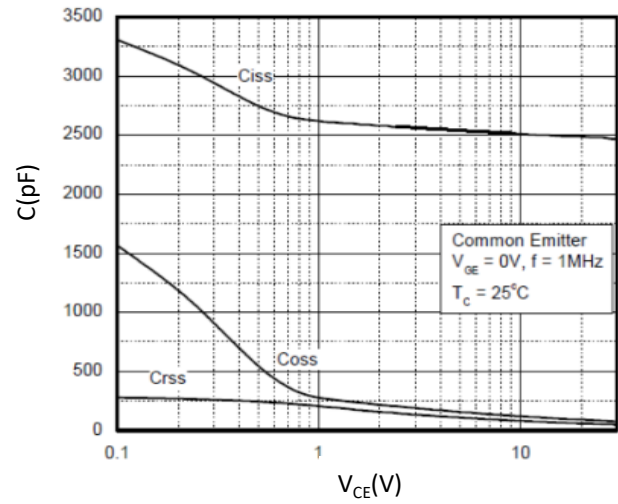

正向偏压二极管
Diode forward voltage as a function of junction temperature

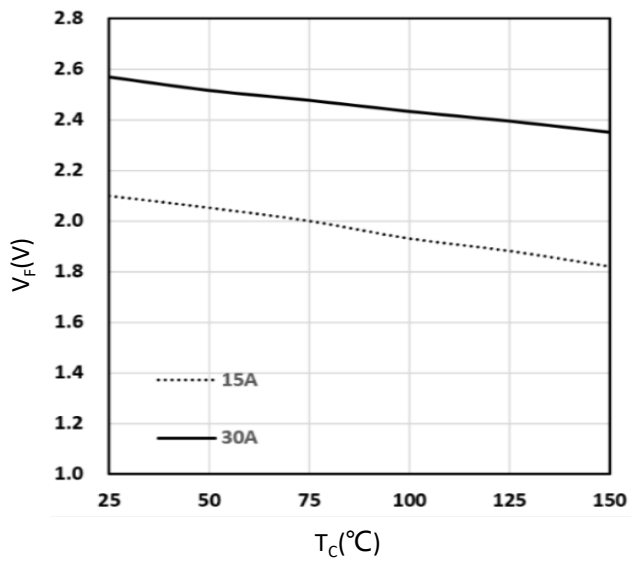

功耗
Power dissipation as a function of case temperature
 $P_D=f(T_c)$

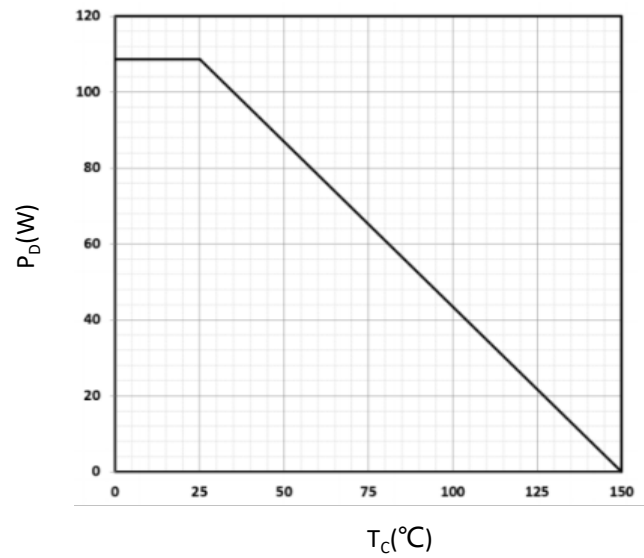

开关损耗二极管
Switching losses Diode
 $Err = f(di/dt)$
 $V_{GE}=15V, I_C=15A, V_{CE}=600V$

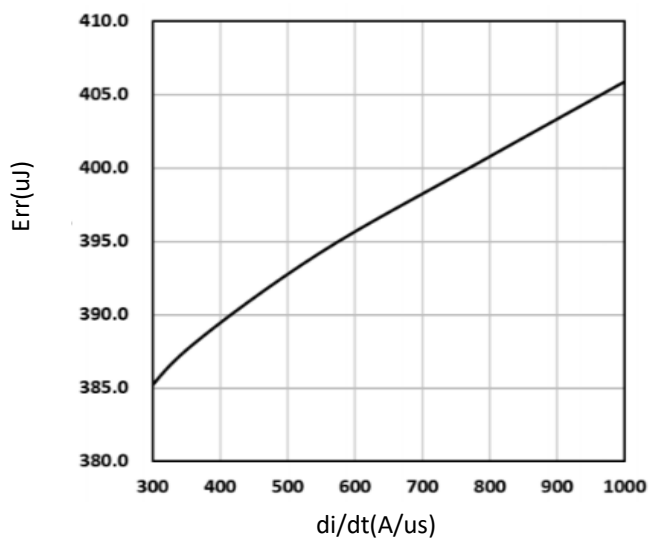

瞬态热阻抗
normalized transient thermal impedance, junction to case
 $Z_{thjc}=f(t)$

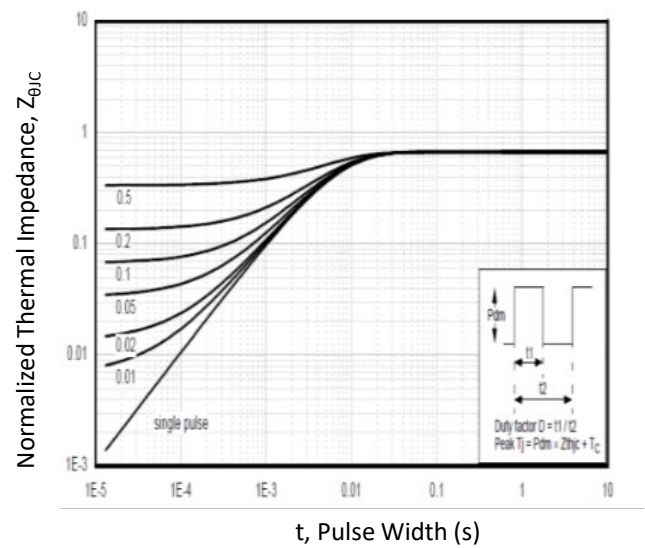

封装尺寸/package outlines

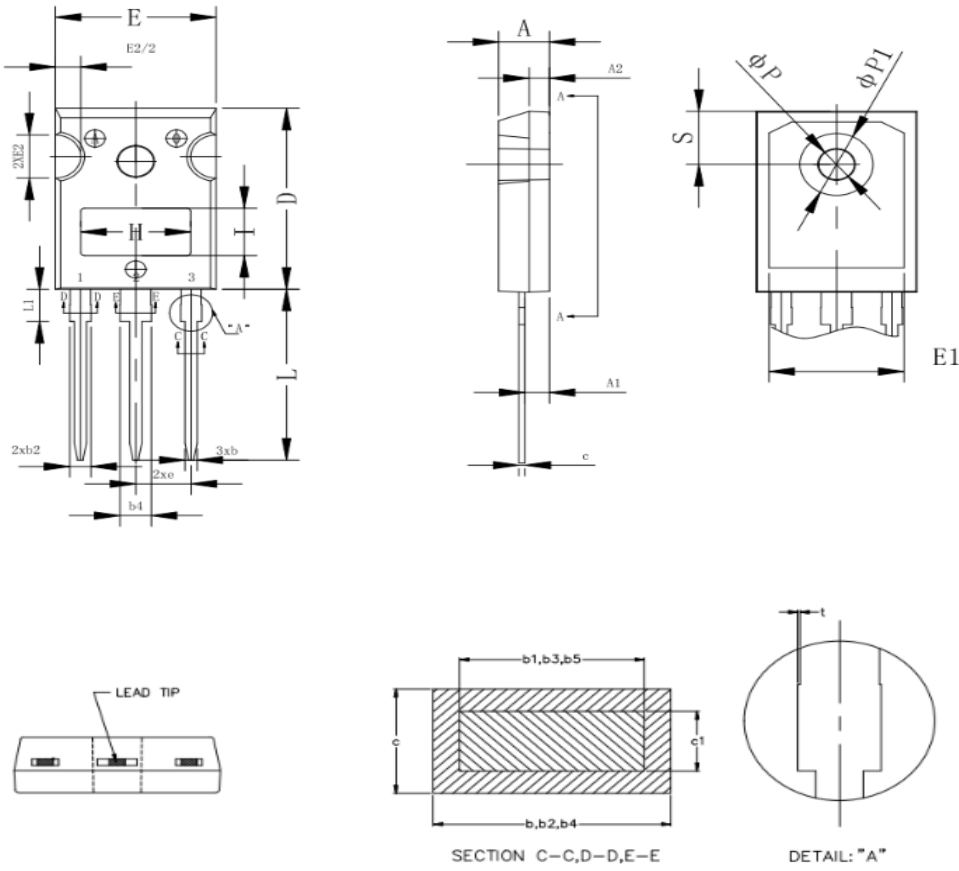

SYMBOLS	DIMENSIONS			
	mm		inch	
	Min.	Max.	Min.	Max.
A	4.9	5.1	0.193	0.201
A1	2.31	2.51	0.091	0.099
A2	1.90	2.10	0.075	0.083
b	1.16	1.26	0.046	0.050
b1	1.15	1.22	0.045	0.048
b2	1.96	2.06	0.077	0.081
b3	1.95	2.02	0.077	0.080
b4	2.96	3.06	0.117	0.120
b5	2.95	3.02	0.116	0.119
c	0.59	0.66	0.023	0.026
c1	0.58	0.62	0.023	0.024
D	20.90	21.10	0.823	0.831
D1	16.25	16.85	0.640	0.663
D2	1.05	1.35	0.041	0.053
E	15.75	15.90	0.620	0.626
E1	13.26	-	0.552	-
E2	4.90	5.10	0.193	0.201
e	5.44BSC		0.214BSC	
L	19.80	20.10	0.780	0.791
L1	-	4.30	-	0.169
φP	3.5	3.7	0.138	0.146
φP1	-	7.40	-	0.291
S	6.05	6.25	0.238	0.246
t	0.00	0.15	0.000	0.006
H	10.6	11.2	0.417	0.441
I	5.3	5.7	0.209	0.224