

DATE: 2020年9月2日

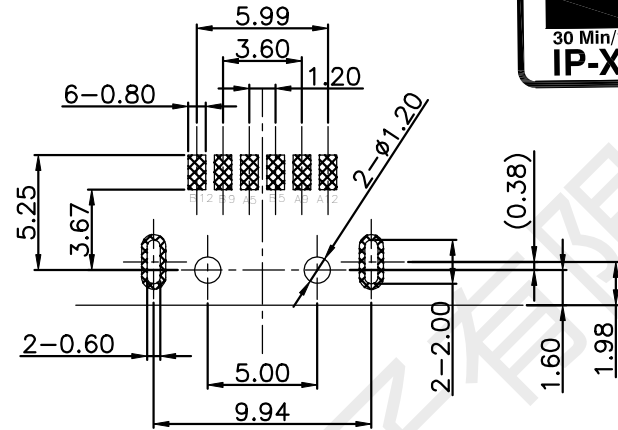

SPECIFICATION:

1. CURRENT RATING: 3.0A MAX
2. DIELECTRIC WITHSTAND VOLTAGE: 100VAC
3. TEMPERATURE RANGE: -30 °C ~ 85 °C
4. CONTACT RESISTANCE: 40 MILLIONHM MAX
5. INSULATION RESISTANCE: 100 MEGOHMS MIN.
6. INSERTION FORCE : 5N~20N
7. UNMATING FORCE: 8N~20N
8. DURABILITY:10,000 CYCLES
9. WATER PROOFNESS:THIS PRODUCT IS BASED ON IPX 8.

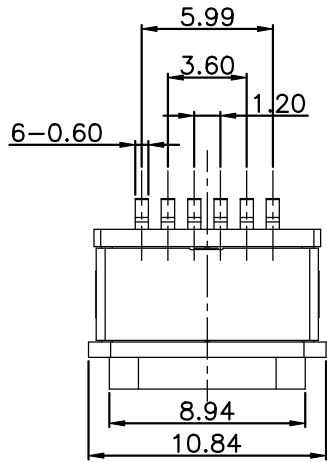

Recommended P. C. B. Layout
Unspecified tolerance: ±0.05
(Top view)

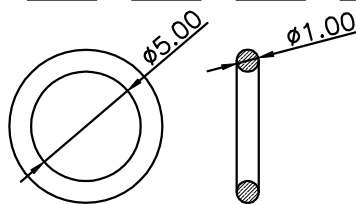
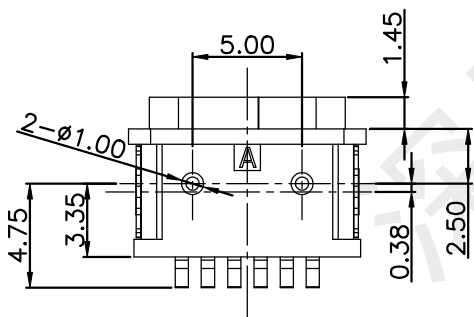
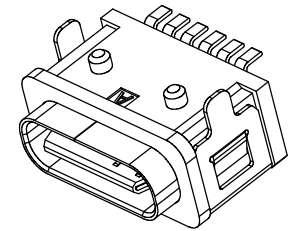
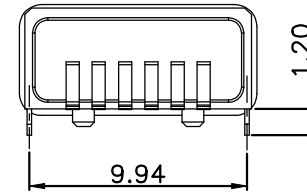
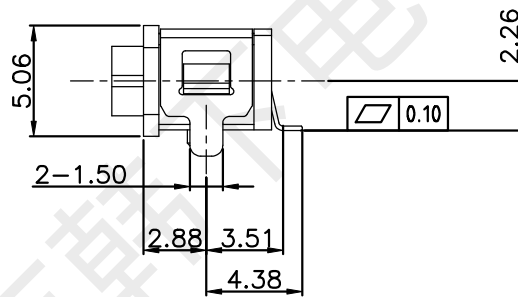
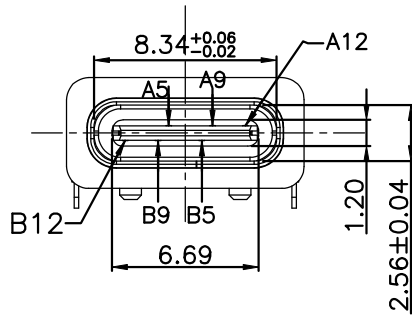

注: 防水圈是圆形截面, 直径为1.0mm的硅胶圈, 防水圈挤压量, 由1.0mm挤压到0.5mm ~ 0.6mm, 防水效果好

A5	CC1	B12	GND
A9	VBUS	B9	VBUS
A12	GND	B5	CC2
PIN	SIGNAL NAME	PIN	SIGNAL NAME

5	Shell2	1	SUS301 Ni Plating T=0.20mm	Ni:40u"Min;
4	Shell1	1	SUS301 Ni Plating T=0.25mm	Ni:40u"Min;
3	Housing2	1	PA10T(G.F30%)	
2	Contact	6	Phosphor bronze C5210R-EH Au/Ni Plating T=0.20mm	Ni:40u"Min; Au:CONTACT AREA:1u", OTHER AREA:G/F
1	Housing	1	PA10T (G.F30%)	
ITEM	PART NAME	Q' TY	FINISH	NOTE
		UNITS	深圳市韩下电子有限公司	
		mm		
		MAT'L	PART NO.	TITLE: HX TYPE-C 6P+2J IPX8
X.	±0.50	X.°	± 2°	DWG NO.:
.X	±0.30	.X°	± 1°	
.XX	±0.10	.XX°	± 0.5°	
.XXX	±0.05			
		FINISH	DRAW: 黄彬	
		Q' TY	CHED: 张伟	
			APPD: 罗小春	
			SCALE	SHEET
			1/1	1/2
				REV. A1