

TTM-100-LIUPN-H1140

Temperature Detection – Miniature Transmitter for External Probes

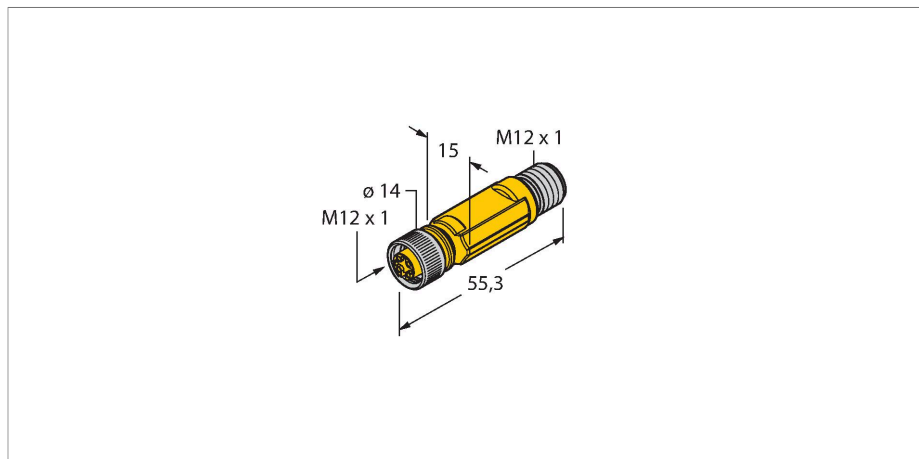

Features

- Miniature design
- Factory setting 0...150 °C
- Parameterizable via IO-Link
- Analog output 4...20 mA (2-wire)
- Switching output
- For connection to external temperature probes

Wiring diagram

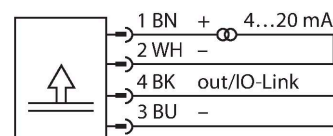

Technical data

Type	TTM-100-LIUPN-H1140
Ident. no.	9910632
Temperature range	
Measuring range	-210...650 °C
Temperature operating range	-346...1202 °F
Factory setting	0...150 °C
	32...302 °F
Note	Max. temperature of electronics: 80 °C/176 °F
Measuring element	for connection to probes of the TP series
Response time	depending on connected temperature probe
Power supply	
Operating voltage	15...30 VDC
Current consumption	≤ 20 mA
Voltage drop at I _e	≤ 2 V
Short-circuit/reverse polarity protection	yes / yes
Protection type and class	IP67 / III
Outputs	
Output 1	Switching output or IO-Link mode
Output 2	analog output
Switching output	
Communication protocol	IO-Link
Output function	NO/NC programmable, PNP/NPN

Functional principle

TP temperature probes (PT100 4-wire) can be plugged directly or via cable to the M12 connection at the TTM100 temperature transmitter.

The temperature signal is transformed into an analog output signal (2-wire 4...20mA) and a switching signal. IO-Link is available for communication and programming.

Technical data

Switching point accuracy	± 0.3 K
Rated operational current	0.15 A
Switching cycles	≥ 100 mil.
Release position	-210...+640 °C
Switching point	-200...+650 °C
Analog output	
Current output	4...20 mA
Load	≤ [(Vsupply - 10 V)/21 mA] kΩ
Accuracy (Lin. + Hys. + Rep.)	± 0.3 K
Remark	0.1 % of full scale applies to temperatures > +300 °C
Repeatability	0.1 K
IO-Link	
IO-Link specification	Specified acc. to version 1.1
Programming	FDT / DTM
Transmission physics	corresponds to 3-wire physics (PHY2)
Transmission rate	COM 2 / 38.4 kbps
Process data width	16 bit
Measured value information	15 bit
Switchpoint information	1 bit
Frame type	2.2
Genauigkeit	± 0.2 K
Included in the SIDI GSDML	Yes
Temperature behaviour	
Temperature coefficient zero point Tk0	± 0.1 % of full scale/10 K
Temperature coefficient span T _{ks}	± 0.1 % of full scale/10 K
Ambient conditions	
Ambient temperature	-40...+80 °C
Storage temperature	-40...+80 °C
Housing	
Housing material	Stainless-steel/Plastic, V4A (1.4404)
Process connection	M12 × 1
Electrical connection	Connector, M12 × 1
Reference conditions acc. to IEC 61298-1	
Temperature	15...+25 °C
Atmospheric pressure	860...1060 hPa abs.
Humidity	45...75 % rel.
Auxiliary power	24 VDC

Technical data

MTTF

541 years acc. to SN 29500 (Ed. 99) 40 °C
