



ALL RIGHTS RESERVED. NO PORTION OF THIS PUBLICATION, WHETHER IN WHOLE OR IN PART CAN BE REPRODUCED WITHOUT THE EXPRESS WRITTEN CONSENT OF SPC TECHNOLOGY.

SPC-F005.DWG

REVISIONS

DOC. NO. SPC-F005 * Effective: 7/8/02 * DCP No: 1398

DCP #	REV	DESCRIPTION	DRAWN	DATE	CHECKD	DATE	APPRVD	DATE
1876	A	RELEASED	EO	5/4/2006	TL	05/15/06	HO	05/15/06



RoHS Compliant

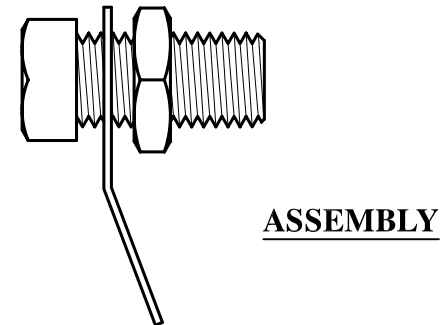
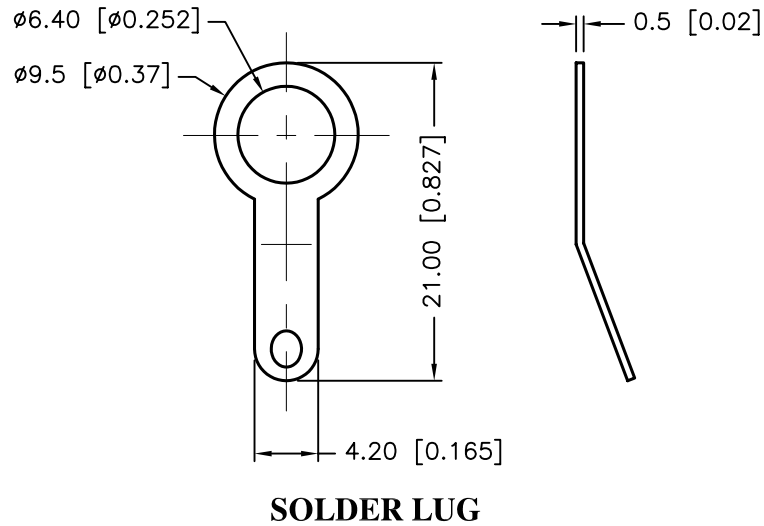
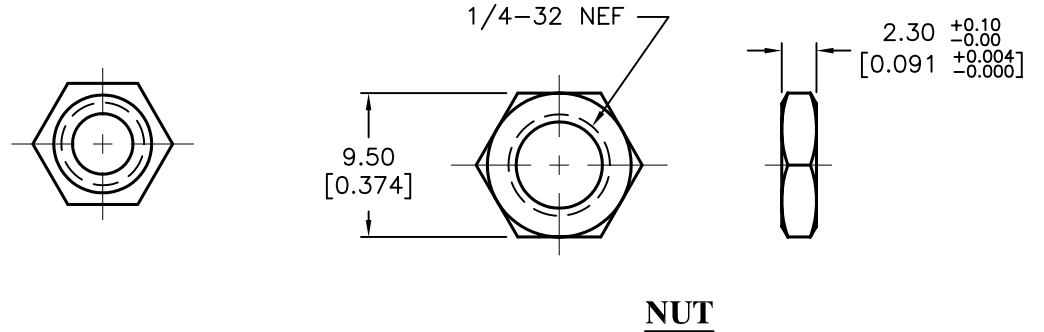
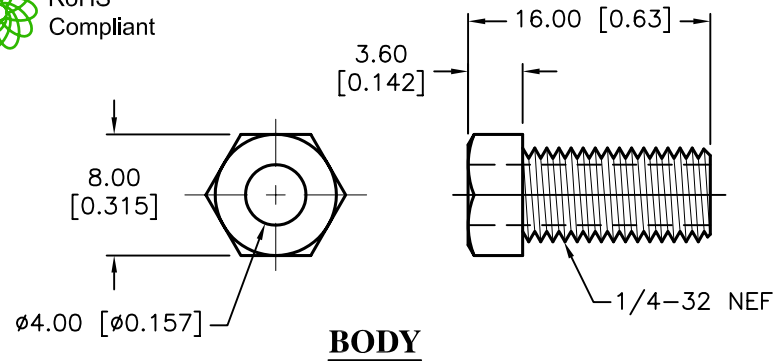

Material:

1. Body: Brass, Nickel-Plated
2. Nut: Brass, Nickel-Plated
3. Solder Lug: Brass, Nickel-Plated

DISCLAIMER:
ALL STATEMENTS AND TECHNICAL INFORMATION CONTAINED HEREIN ARE BASED UPON INFORMATION AND/OR TESTS WE BELIEVE TO BE ACCURATE AND RELIABLE. SINCE CONDITIONS OF USE ARE BEYOND OUR CONTROL, THE USER SHALL DETERMINE THE SUITABILITY OF THE PRODUCT FOR THE INTENDED USE AND ASSUME ALL RISK AND LIABILITY WHATSOEVER IN CONNECTION THEREWITH.

TOLERANCES:

Unless Otherwise Specified
.X ±0.2 [0.008]
.XX ±0.12 [0.005]

DRAWN BY:	DATE:
EKLAS ODISH	5/4/2006
CHECKED BY:	DATE:
THOMAS LEE	05/15/06
APPROVED BY:	DATE:
HISHAM ODISH	05/15/06

DRAWING TITLE: RoHS Compliant, Metal Banana Jack			
SIZE	DWG. NO.	ELECTRONIC FILE	REV
A	SPC15459	79K5034.DWG	A
SCALE: NTS	U.O.M.: mm [INCHES]	SHEET: 1 OF 1	