

TL431 Adjustable Reference Source

TL431

Adjustable Accurate Reference Source

DEVICE DESCRIPTION

The TL431 is a three-terminal adjustable shunt regulator offering excellent temperature stability. This device has a typical dynamic output impedance of 0.2Ω. The device can be used as a replacement for zener diodes in many applications.

FEATURES

- The output voltage can be adjusted to 36V
- Low dynamic output impedance, its typical value is 0.2Ω
- Trapping current capability is 1 to 100mA
- Low output noise voltage
- Fast on-state response
- The effective temperature compensation in the working range of full temperature
- The typical value of the equivalent temperature factor in the whole temperature scope is 50 ppm/°C

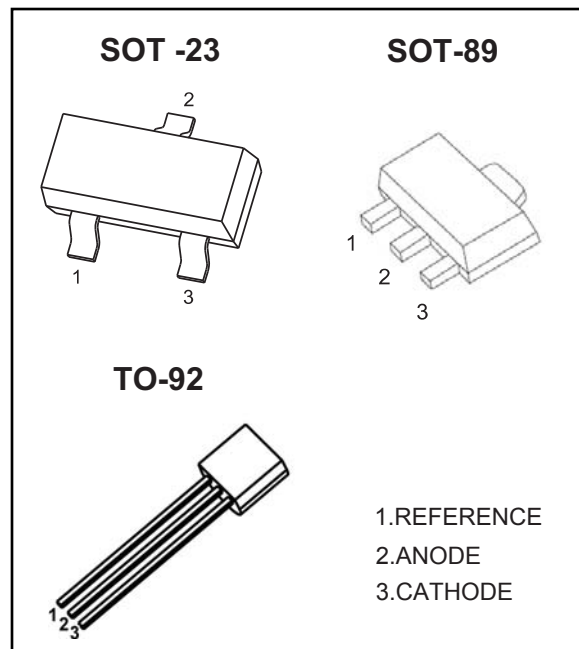

APPLICATION

- Shunt Regulator
- High-Current Shunt Regulator
- Precision Current Limiter

FUNCTION BLOCK DIAGRAM

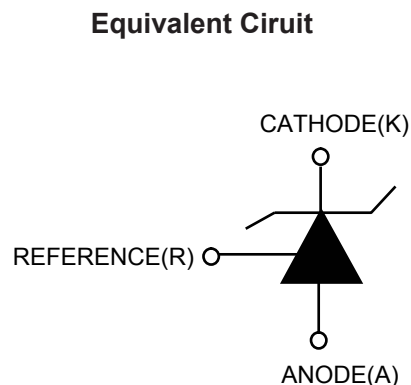
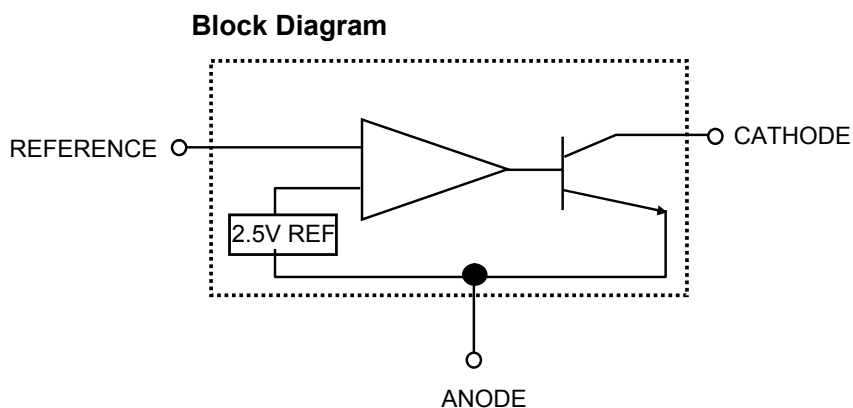

ORDERING INFORMATION

Part Number	MARKING ⁽¹⁾	Package	Packing Method	Pack Quantity
TL431	431	SOT-23	Reel	3000pcs/Reel
TL431	431	SOT-89	Reel	1000pcs/Reel
TL431	TL431 XXX ⁽²⁾	TO-92	Bulk	1000pcs/Bag
TL431	TL431 XXX ⁽²⁾	TO-92	Tape	2000pcs/Box

Notes: (1). Solid dot= Green molding compound device, if none, the normal device.

(2). XXX=Code

ABSOLUTE MAXIMUM RATINGS (Operating temperature range applies unless otherwise specified)

Parameter	Symbol	Value			Unit
		SOT-23	SOT-89	TO-92	
Cathode Voltage	V_{KA}	37			V
Cathode Current Range (Continuous)	I_{KA}	-100~+150			mA
Reference Input Current Range	I_{ref}	0.05~+10			mA
Power Dissipation	P_D	300	500	770	mW
Thermal Resistance from Junction to Ambient	$R_{\theta JA}$	417	250	162	°C/W
Operating Temperature	T_{opr}	-25~+85			°C
Junction Temperature	T_J	150			°C
Storage Temperature Range	T_{STG}	-65~+150			°C

TL431-0.3% ELECTRICAL CHARACTERISTICS ($T_a=25^\circ\text{C}$ unless otherwise specified)

Parameter	Symbol	Cir-Cuit	Test conditions	Min	Typ	Max	Unit
Reference input voltage	V_{ref}	1	$V_{KA}=V_{REF}, I_{KA}=10\text{mA}$	2.487	2.495	2.502	V
Deviation of reference Input voltage over temperature (note)	$\Delta V_{ref}/\Delta T$	1	$V_{KA}=V_{REF}, I_{KA}=10\text{mA}$ $T_{MIN}\leq T_a\leq T_{MAX}$		3	17	mV
Ratio of change in reference Input voltage to the change in cathode voltage	$\Delta V_{ref}/\Delta V_{KA}$	2	$I_{KA}=10\text{mA}$	$\Delta V_{KA}=10\text{V}-V_{REF}$	-1.4	-2.7	mV/V
				$\Delta V_{KA}=36\text{V}-10\text{V}$	-1	-2	mV/V
Reference input current	I_{ref}	2	$I_{KA}=10\text{mA}, R_1=10\text{k}\Omega$ $R_2=\infty$		1.8	4	μA
Deviation of reference input current over full temperature range	$\Delta I_{ref}/\Delta T$	2	$I_{KA}=10\text{mA}, R_1=10\text{k}\Omega$ $R_2=\infty$ $T_A=-25\text{ to }85^\circ\text{C}$		0.4	1.2	μA
Minimum cathode current for regulation	$I_{KA(min)}$	1	$V_{KA}=V_{REF}$			0.15	mA
Off-state cathode current	$I_{KA(OFF)}$	3	$V_{KA}=36\text{V}, V_{REF}=0$		0.2	1	μA
Dynamic impedance	Z_{KA}	1	$V_{KA}=V_{REF}, I_{KA}=1\text{ to }100\text{mA}$ $f\leq 1.0\text{kHz}$		0.2	0.5	Ω

Note: $T_{MIN}=-25^\circ\text{C}$, $T_{MAX}=+85^\circ\text{C}$

TL431-0.5% ELECTRICAL CHARACTERISTICS (T_a=25°C unless otherwise specified)

Parameter	Symbol	Cir-Cuit	Test conditions	Min	Typ	Max	Unit
Reference input voltage	V _{ref}	1	V _{KA} =V _{REF} , I _{KA} =10mA	2.482	2.495	2.507	V
Deviation of reference Input voltage over temperature (note)	ΔV _{ref} /ΔT	1	V _{KA} =V _{REF} , I _{KA} =10mA T _{MIN} ≤T _a ≤T _{MAX}		3	17	mV
Ratio of change in reference Input voltage to the change in cathode voltage	ΔV _{ref} /ΔV _{KA}	2	I _{KA} =10mA	ΔV _{KA} =10V~V _{REF}	-1.4	-2.7	mV/V
				ΔV _{KA} =36V~10V	-1	-2	mV/V
Reference input current	I _{ref}	2	I _{KA} =10mA, R ₁ =10kΩ R ₂ =∞		1.8	4	μA
Deviation of reference input current over full temperature range	ΔI _{ref} /ΔT	2	I _{KA} =10mA, R ₁ =10kΩ R ₂ =∞ T _A =-25 to 85°C		0.4	1.2	μA
Minimum cathode current for regulation	I _{KA(min)}	1	V _{KA} =V _{REF}			0.15	mA
Off-state cathode current	I _{KA(OFF)}	3	V _{KA} =36V, V _{REF} =0		0.2	1	μA
Dynamic impedance	Z _{KA}	1	V _{KA} =V _{REF} , I _{KA} =1 to 100mA f≤1.0kHz		0.2	0.5	Ω

TL431-1% ELECTRICAL CHARACTERISTICS (T_a=25°C unless otherwise specified)

Parameter	Symbol	Cir-Cuit	Test conditions	Min	Typ	Max	Unit
Reference input voltage	V _{ref}	1	V _{KA} =V _{REF} , I _{KA} =10mA	2.47	2.495	2.52	V
Deviation of reference Input voltage over temperature (note)	ΔV _{ref} /ΔT	1	V _{KA} =V _{REF} , I _{KA} =10mA T _{MIN} ≤T _a ≤T _{MAX}		3	17	mV
Ratio of change in reference Input voltage to the change in cathode voltage	ΔV _{ref} /ΔV _{KA}	2	I _{KA} =10mA	ΔV _{KA} =10V~V _{REF}	-1.4	-2.7	mV/V
				ΔV _{KA} =36V~10V	-1	-2	mV/V
Reference input current	I _{ref}	2	I _{KA} =10mA, R ₁ =10kΩ R ₂ =∞		1.8	4	μA
Deviation of reference input current over full temperature range	ΔI _{ref} /ΔT	2	I _{KA} =10mA, R ₁ =10kΩ R ₂ =∞ T _A =-25 to 85°C		0.4	1.2	μA
Minimum cathode current for regulation	I _{KA(min)}	1	V _{KA} =V _{REF}			0.15	mA
Off-state cathode current	I _{KA(OFF)}	3	V _{KA} =36V, V _{REF} =0		0.2	1	μA
Dynamic impedance	Z _{KA}	1	V _{KA} =V _{REF} , I _{KA} =1 to 100mA f≤1.0kHz		0.2	0.5	Ω

Note: T_{MIN}=-25°C, T_{MAX}=+85°C

CLASSIFICATION cZV_{ref}

Rank	*** 0.3%	*** 0.5%	* 1%
Range	2.487-2.502	2.482-2.507	2.47-2.52

Test Circuit

Fig. 1 Test Circuit for $V_{KA} = V_{REF}$

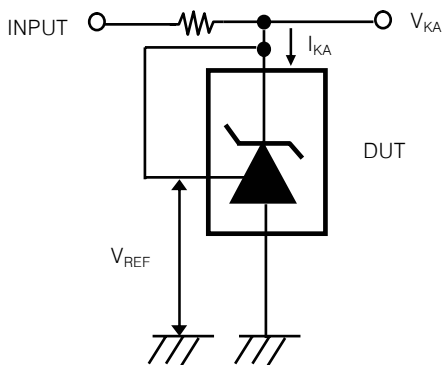

Fig. 2 Test Circuit for $V_{KA} \geq V_{REF}$

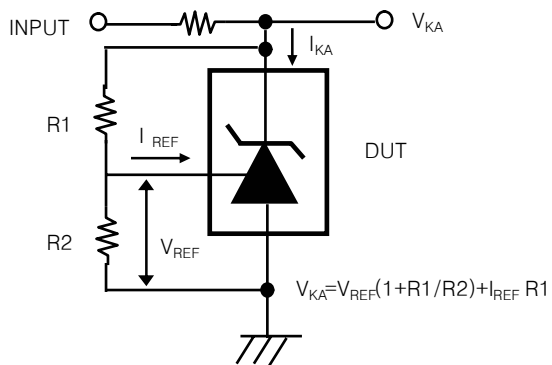
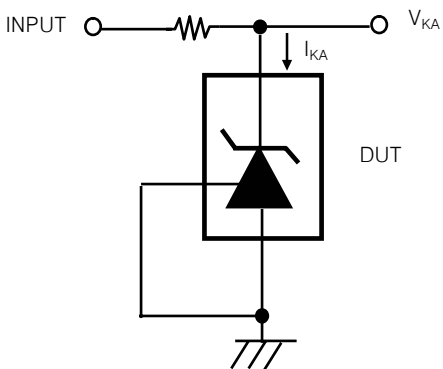
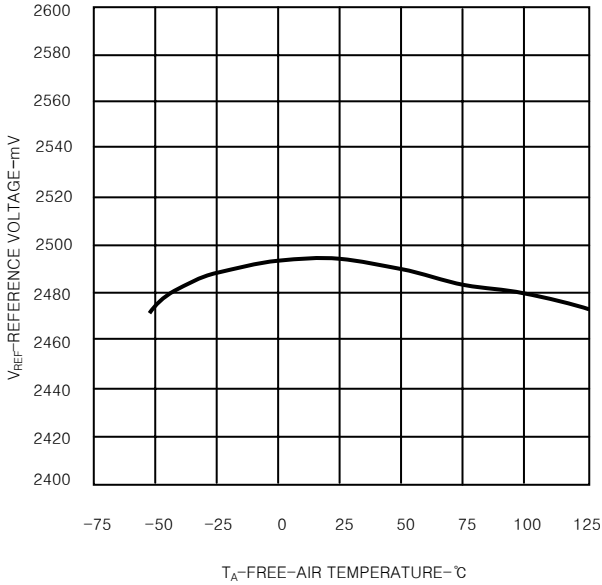

Fig. 3 Test Circuit for I_{KA} (off)



Typical Performance Characteristics

REFERENCE VOLTAGE vs
FREE-AIR TEMPERATURE†



REFERENCE CURRENT vs
FREE-AIR TEMPERATURE †

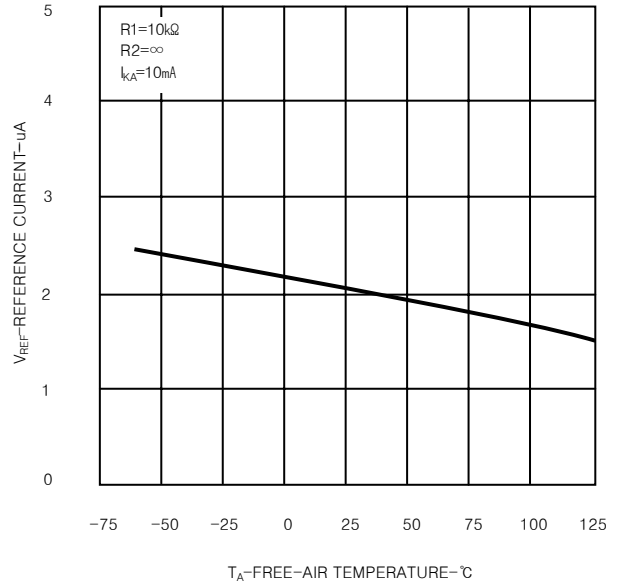

† Data is applicable only within the recommended operating free-air temperature ranges of the various devices.

† Data is applicable only within the recommended operating free-air temperature ranges of the various devices.

‡ Data is for devices having the indicated value of V_{REF} at $I_{KA}=10mA$, $T_A=25^\circ C$

Figure 4.

Figure 5.

CATHODE CURRENT vs
CATHODE VOLTAGE

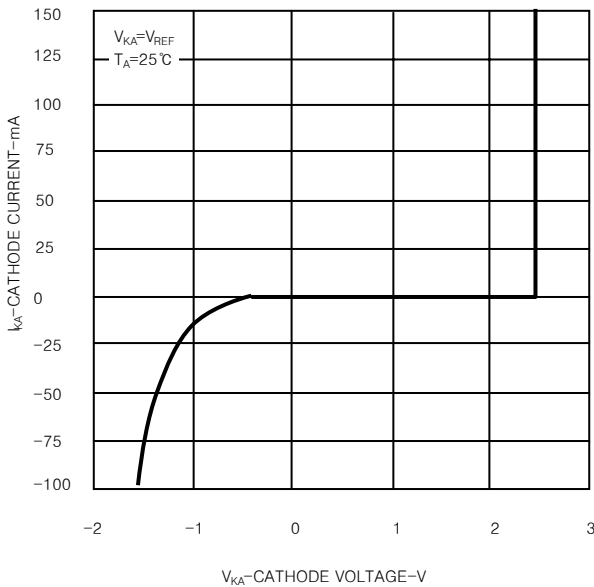

CATHODE CURRENT vs
CATHODE VOLTAGE

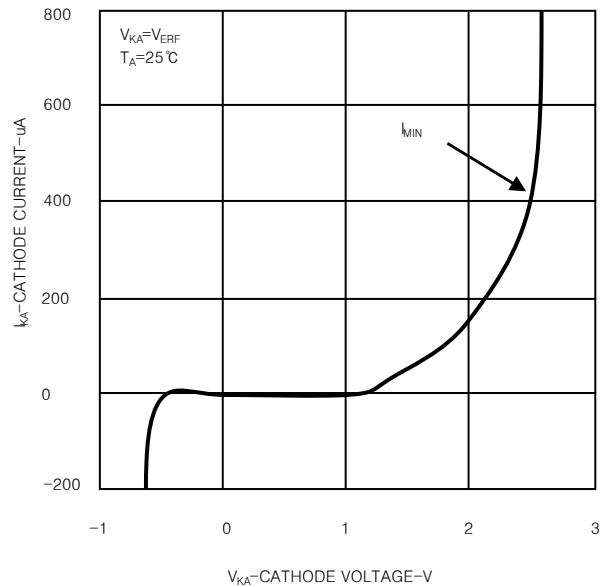
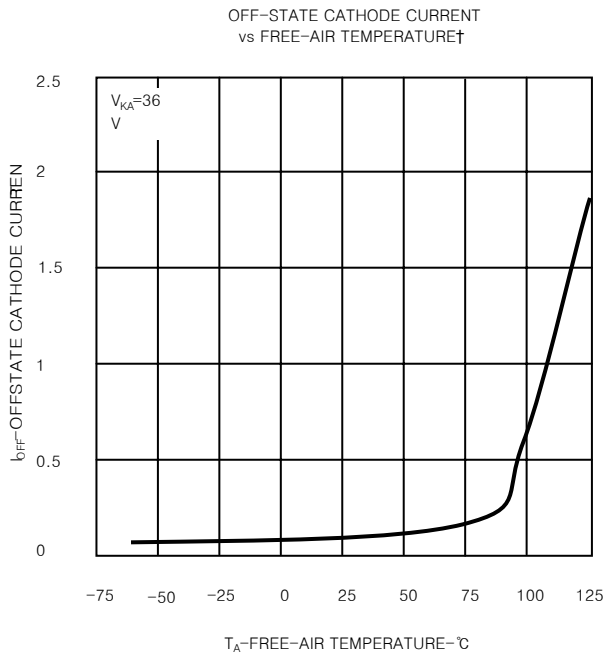

Figure 6.

Figure 7.

The curve above is for reference only.

Typical Performance Characteristics



† Data is applicable only within the recommended operating free-air temperature ranges of the various devices.

Figure 8.

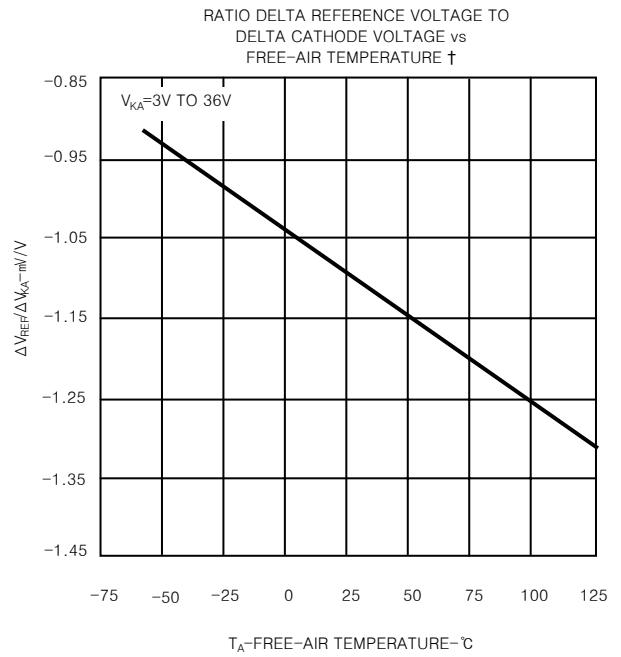

† Data is applicable only within the recommended operating free-air temperature ranges of the various devices.

Figure 9.

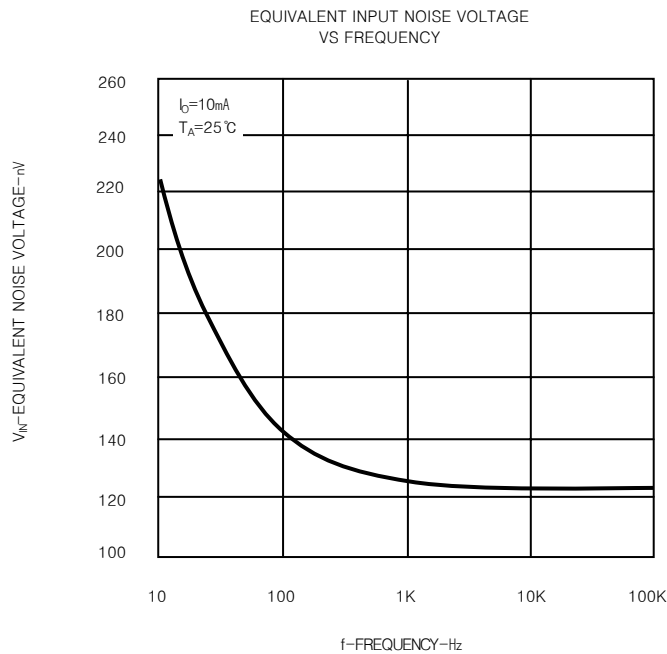
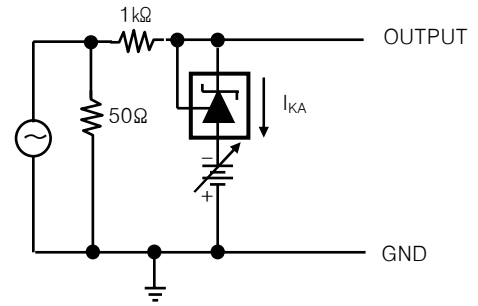
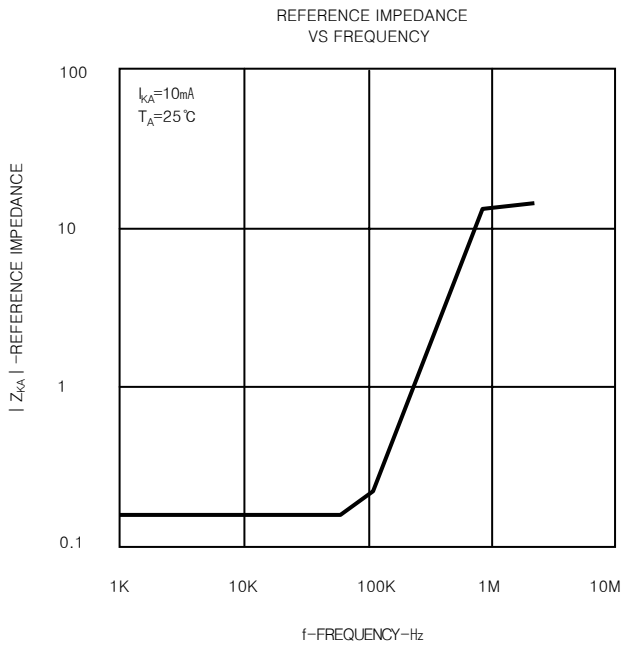

Figure 10.

The curve above is for reference only.

Typical Performance Characteristics



Test Circuit for Reference Impedance

Figure 11.

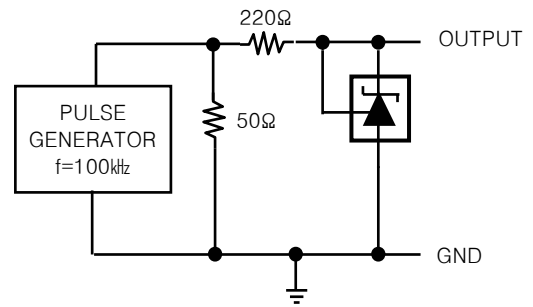
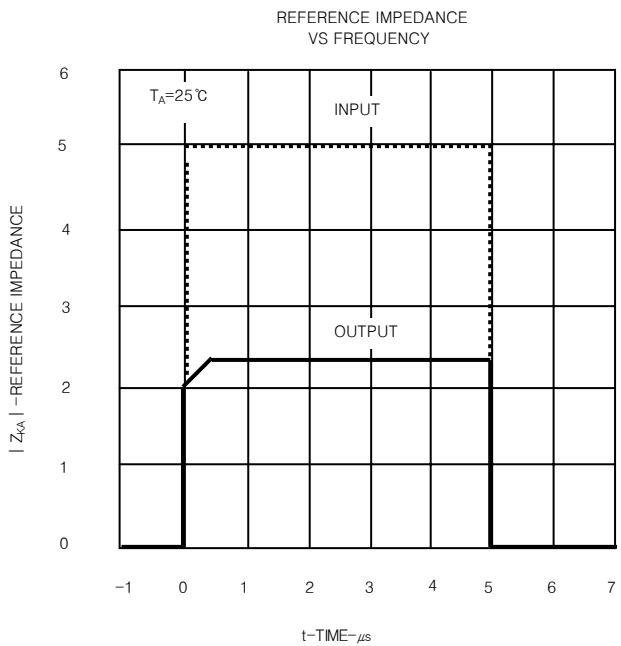

Test Circuit for Pulse Response

Figure 12.

The curve above is for reference only.

Application Information

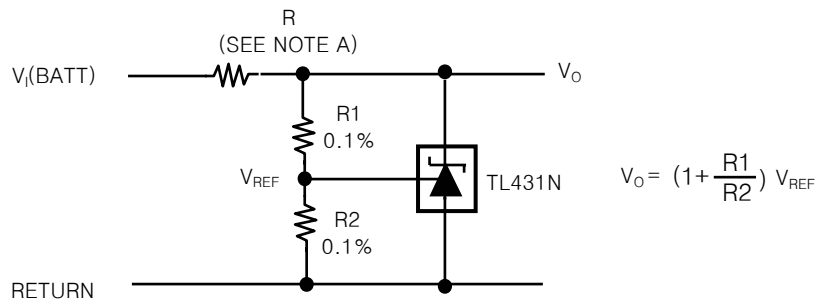

NOTE A : R Should provide cathode current $\geq 1\text{ mA}$ to the TL431N at minimum $V_i(\text{BATT})$

Figure 13. Shunt Regulator

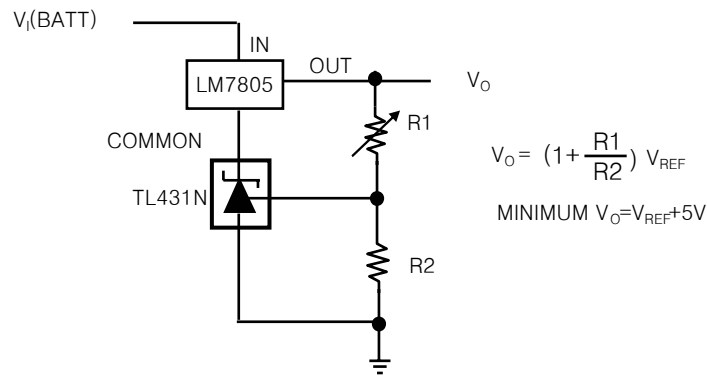

Figure 14. Output Control of a 3-Terminal Fixed Regulator

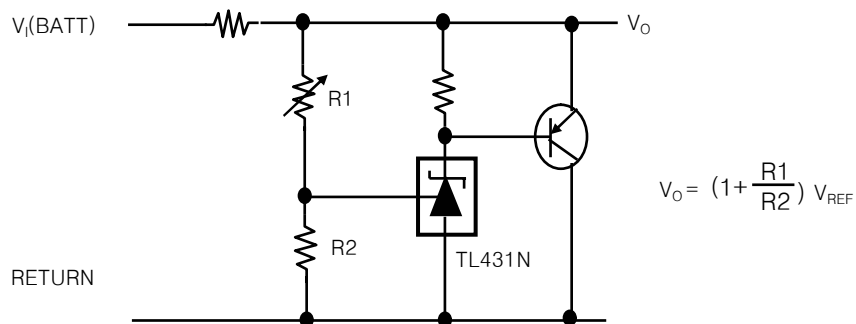
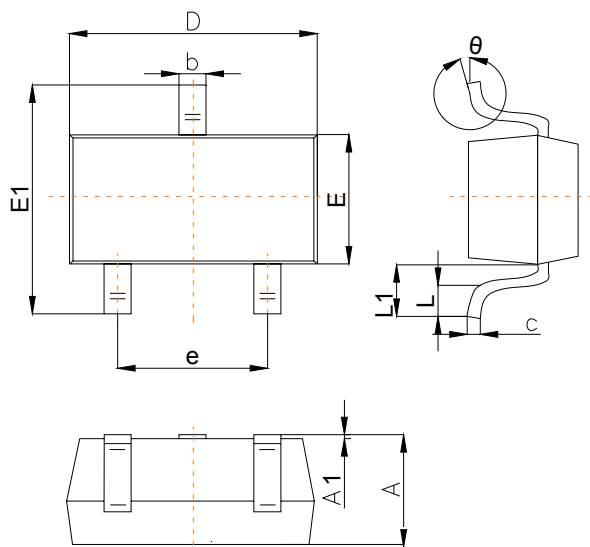

Figure 15. High-Current Shunt Regulator

SOT-23 Outline Drawing

SOT-23 Package Outline Dimensions



Symbol	Dimensions In Millimeters		
	Min	Typ	Max
A	0.90		1.40
A1	0.00		0.10
b	0.30		0.50
c	0.08		0.20
D	2.80	2.90	3.10
E	1.20		1.60
E1	2.25		2.80
e	1.80	1.90	2.00
L	0.10		0.50
L1	0.4		0.55
θ	0°		10°

SOT-23 Suggested Pad Layout

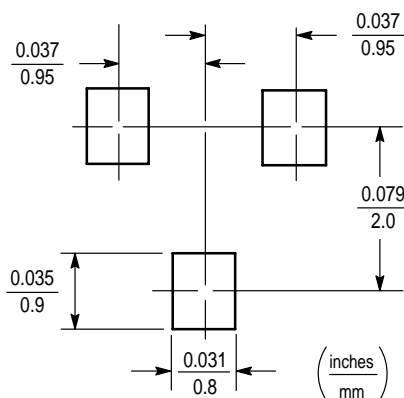

Note:

1. Controlling dimension: in/millimeters.
2. General tolerance: ±0.05mm.
3. The pad layout is for reference purposes only.

SOT-23 Tape and Reel

SOT-23 Embossed Carrier Tape

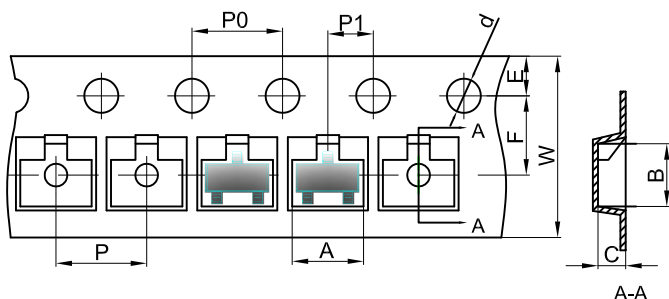

Packaging Description:

SOT-23 parts are shipped in tape. The carrier tape is made from a dissipative (carbon filled) polycarbonate resin. The cover tape is a multilayer film (Heat Activated Adhesive in nature) primarily composed of polyester film, adhesive layer, sealant, and anti-static sprayed agent. These reeled parts in standard option are shipped with 3,000 units per 7" or 17.8cm diameter reel. The reels are clear in color and is made of polystyrene plastic (anti-static coated).

Dimensions are in millimeter										
Pkg type	A	B	C	d	E	F	P0	P	P1	W
SOT-23	3.15	2.77	1.22	Ø1.50	1.75	3.50	4.00	4.00	2.00	8.00

SOT-23 Tape Leader and Trailer

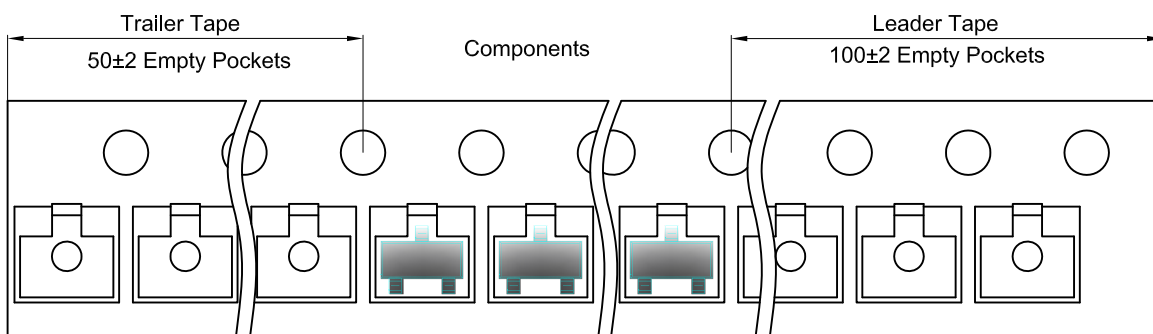

SOT-23 Reel

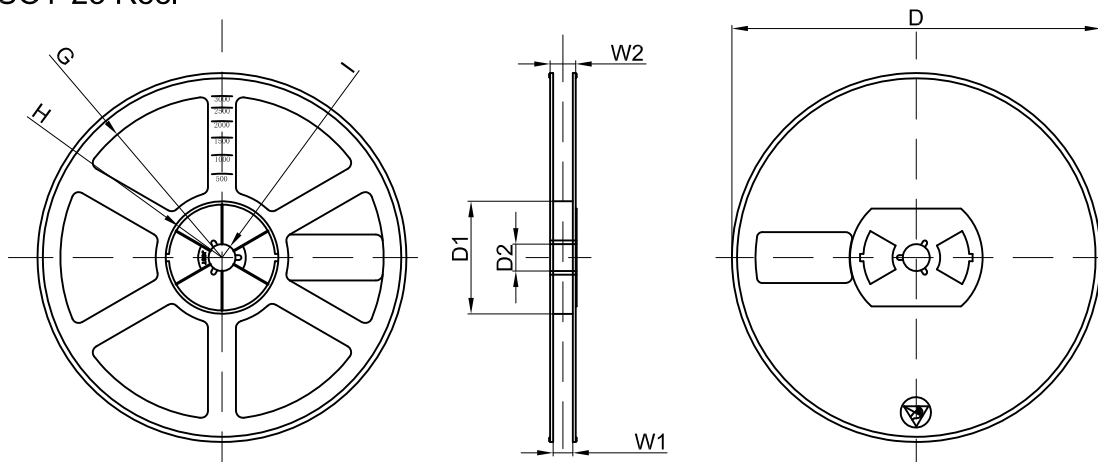

Dimensions are in millimeter								
Reel Option	D	D1	D2	G	H	I	W1	W2
7" Dia	Ø178.00	54.40	13.00	R78.00	R25.60	R6.50	9.50	12.30

REEL	Reel Size	Box	Box Size(mm)	Carton	Carton Size(mm)	G.W.(kg)
3000 pcs	7 Inch	45,000 pcs	203×203×195	180,000 pcs	438×438×220	

SOT-89-3L Outline Drawing

SOT-89-3L Package Outline Dimensions

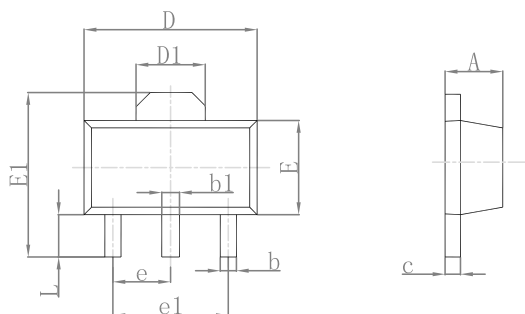

Symbol	Dimensions In Millimeters		Dimensions In Inches	
	Min	Max	Min	Max
A	1.400	1.600	0.055	0.063
b	0.320	0.520	0.013	0.020
b1	0.400	0.580	0.016	0.023
c	0.350	0.440	0.014	0.017
D	4.400	4.600	0.173	0.181
D1	1.550 REF.		0.061 REF.	
E	2.300	2.600	0.091	0.102
E1	3.940	4.250	0.155	0.167
e	1.500 TYP.		0.060 TYP.	
e1	3.000 TYP.		0.118 TYP.	
L	0.900	1.200	0.035	0.047

SOT-89-3L Suggested Pad Layout

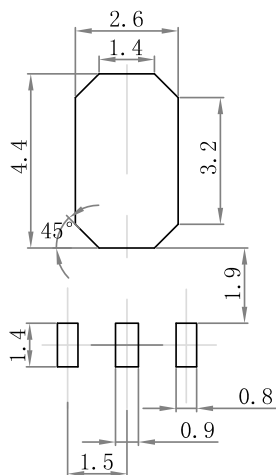

Note:

1. Controlling dimension: in/millimeters.
2. General tolerance: ±0.05mm.
3. The pad layout is for reference purposes only.

SOT-89-3L Tape and Reel

SOT-89-3L Embossed Carrier Tape

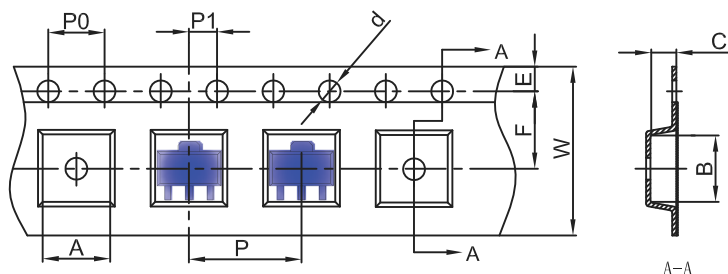

Packaging Description:
 SOT-89-3L parts are shipped in tape. The carrier tape is made from a dissipative (carbon filled) polycarbonate resin. The cover tape is a multilayer film (Heat Activated Adhesive in nature) primarily composed of polyester film, adhesive layer, sealant, and anti-static sprayed agent. These reeled parts in standard option are shipped with 1,000 units per 7" or 18cm diameter reel. The reels are clear in color and is made of polystyrene plastic (anti-static coated).

Dimensions are in millimeter										
Pkg type	A	B	C	d	E	F	P0	P	P1	W
SOT-89-3L	4.85	4.45	1.85	Ø1.50	1.75	5.50	4.00	8.00	2.00	12.00

SOT-89-3L Tape Leader and Trailer

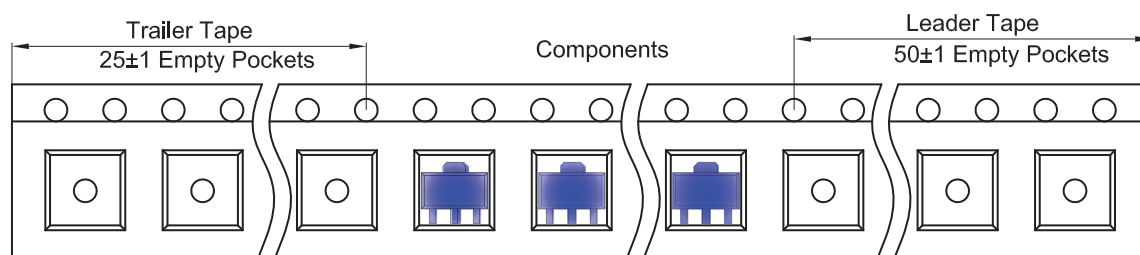

SOT-89-3L Reel

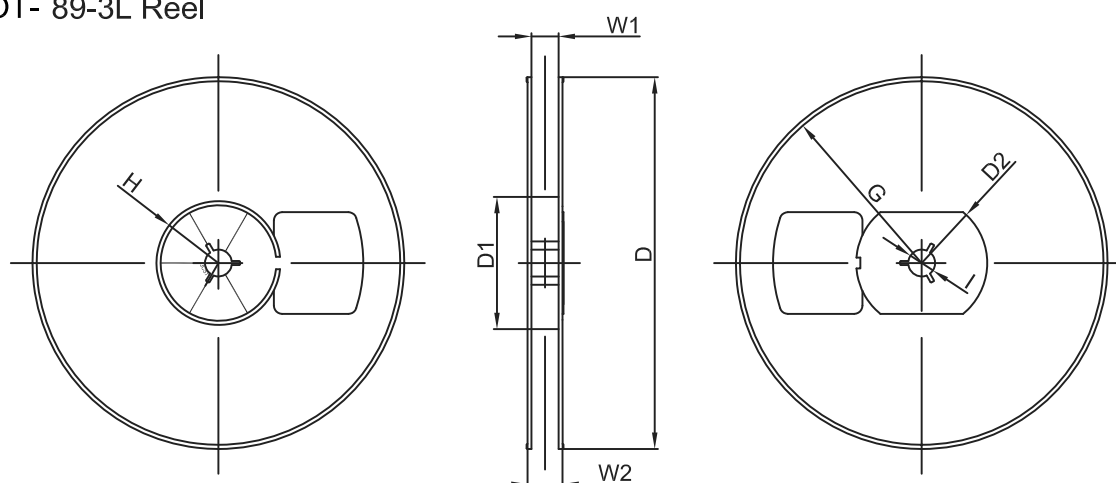

Dimensions are in millimeter								
Reel Option	D	D1	D2	G	H	I	W1	W2
7" Dia	Ø180.00	60.00	R32.00	R86.50	R30.00	Ø13.00	13.20	16.50

REEL	Reel Size	Box	Box Size(mm)	Carton	Carton Size(mm)	G.W.(kg)
1000 pcs	7 Inch	10,000 pcs	203×203×195	40,000 pcs	438×438×220	

TO-92 Outline Drawing

TO-92 Package Outline Dimensions

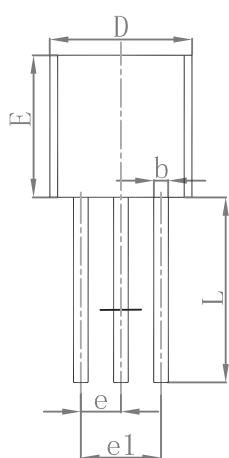
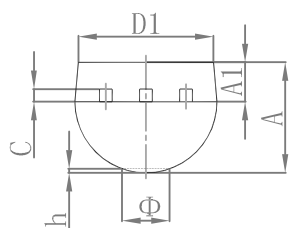

Symbol	Dimensions In Millimeters		Dimensions In Inches	
	Min	Max	Min	Max
A	3.300	3.700	0.130	0.146
A1	1.100	1.400	0.043	0.055
b	0.380	0.550	0.015	0.022
c	0.360	0.510	0.014	0.020
D	4.300	4.700	0.169	0.185
D1	3.430		0.135	
E	4.300	4.700	0.169	0.185
e	1.270 TYP		0.050 TYP	
e1	2.440	2.640	0.096	0.104
L	14.100	14.500	0.555	0.571
Φ		1.600		0.063
h	0.000	0.380	0.000	0.015

TO-92 Suggested Pad Layout

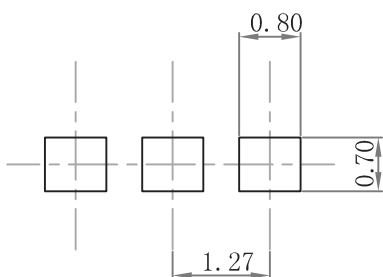

Note:

1. Controlling dimension: in/millimeters.
2. General tolerance: ±0.05mm.
3. The pad layout is for reference purposes only.

TO-92 Tape and Reel

TO-92 Package Taping Dimension

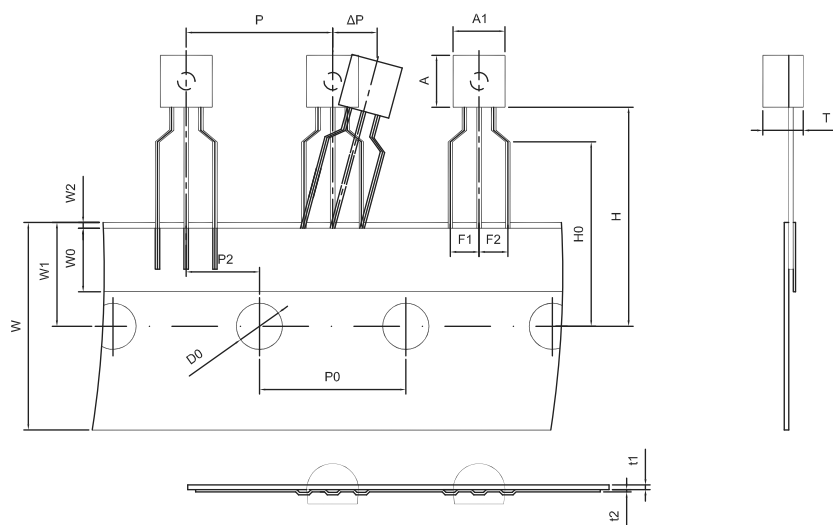

Dimensions are in millimeter

A1	A	T	P	P0	P2	F1	F2	W
4.5	4.5	3.5	12.7	12.7	6.35	2.5	2.5	18.0
W0	W1	W2	H	H0	D0	t1	t2	ΔP
6.0	9.0	1.0 MAX.	19.0	16.0	4.0	0.4	0.2	0

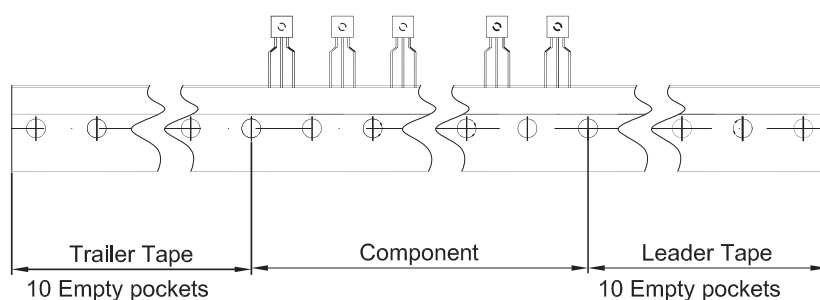

Package	Box	Box Size(mm)	Carton	Carton Size(mm)	G.W.(kg)
TO-92	2,000 pcs	333×162×43	20,000 pcs	350×340×250	