

Shell size	Appliance mounting Part No.	Hood mounting Part No.	A	B	C	D
1	F-GV-1 F-GV-1M3	F-GV-1H F-GV-1HM3	±0,3	±0,15	±0,2	4-40UNC M3
2	F-GV-2 F-GV-2M3	F-GV-2H F-GV-2HM3	35,1	25	12,5	4-40UNC M3
3	F-GV-3 F-GV-3M3	F-GV-3H F-GV-3HM3	43,1	33,3	12,5	4-40UNC M3
4	F-GV-4 F-GV-4M3	F-GV-4H F-GV-4HM3	56,94	47,04	12,5	4-40UNC M3
5	F-GV-5 F-GV-5M3	F-GV-5H F-GV-5HM3	73,3	63,5	12,5	4-40UNC M3
			72	61,1	14,7	4-40UNC M3

	E	F
for mounting on the hood	12,4	10,0
for mounting on the appliance	10,9	8,5

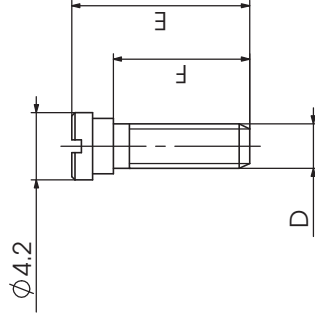
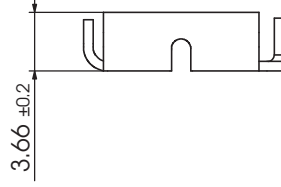
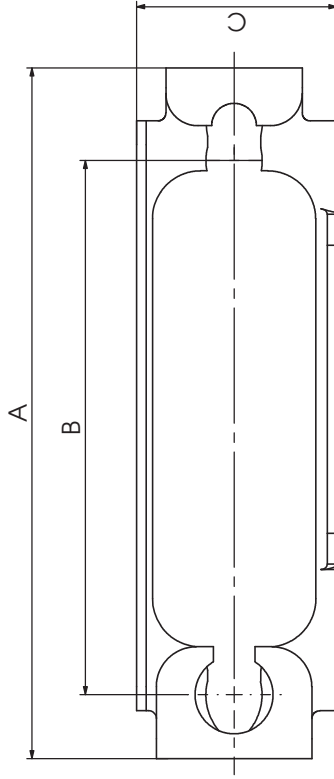

PACKING UNIT:

F-GV-1 to 5 and F-GV-1M3 to 5M3 with 2 screws, 2 spring washers and 2 nuts
 F-GV-1H to 5H and F-GV-1HM3 to 5HM3 with 2 screws

REV.	DATE	CH-NO.	TITLE
1			Slide Lock

Measurement without tolerance acc. to ISO 2768-m	SCALE
NAME / DATE	2:1
DRAWN	sschref
CHECKED	friedrich.Foasmann
	12.05.2009
	12.05.2009

DWG. NO.	F-GV-1-5
REPLACEMENT FOR:	F-GV-1-5, D
PAGES	1