

Low-Voltage SPDT Analog Switch, 2:1 Multiplexer / Demultiplexer Bus Switch

Features

- 1.65V to 5.5V Single Supply Operation
- Low ON-State Resistance: 4.5Ω(Typ.)
- -3dB Bandwidth: 300 MHz Typical
- Low Power Consumption
- Fast Switching Speed
- Break-Before-Make Operation
- Rail-to-Rail Operation
- TTL/CMOS Logic Compatible
- Supports Analog and Digital Signals
- Small Packaging: SOT23-6, SC70-6
- Extended Industrial Temperature Range: -40°C to +125°C

Applications

- Multiple-Purpose Signal Switching
- MP3/PDA
- Portable Devices
- Set-Top Box
- Signal Gating, Multiplexer/Demultiplexer
- Signal Modulation or Demodulation
- Sample and Hold Systems
- Telecom Signal Switching
- Battery Power Systems

Rev1.0

Copyright©2018 Cosine Nanoelectronics Inc. All rights reserved
The information provided here is believed to be accurate and reliable. Cosine Nanoelectronics assumes no reliability for inaccuracies and omissions. Specifications described and contained here are subjected to change without notice on the purpose of improving the design and performance. All of this information described herein should not be implied or granted for any third party.

General Description

The COS3157 is a low voltage, high bandwidth single-pole / double-throw (SPDT) CMOS analog switch or 2:1 multiplexer / demultiplexer with single output enable control pin. The device can pass signals with rail-to-rail swing from a single supply 1.65V to 5.5V. The switches conduct equally well in both directions when it is on. The output enable pin place the signal paths in high impedance which isolates the bus when it is not in use and thus consume less current.

The COS3157 offers low ON-state resistance and high bandwidth with the break-before-make feature which prevents signal distortion during the transferring of a signal from one channel to another. The device is well suitable for the switching of high-speed signals in handset and consumer applications.

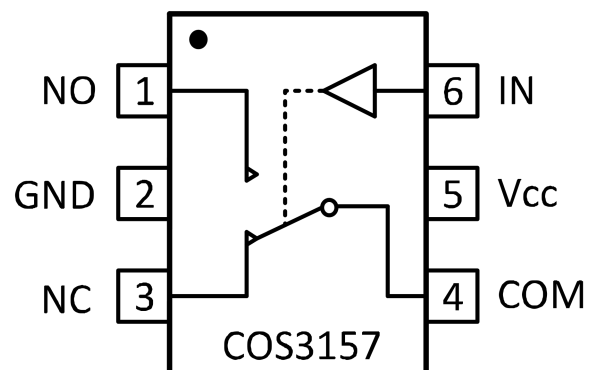

Pin Diagram

1. Pin Configuration and Functions

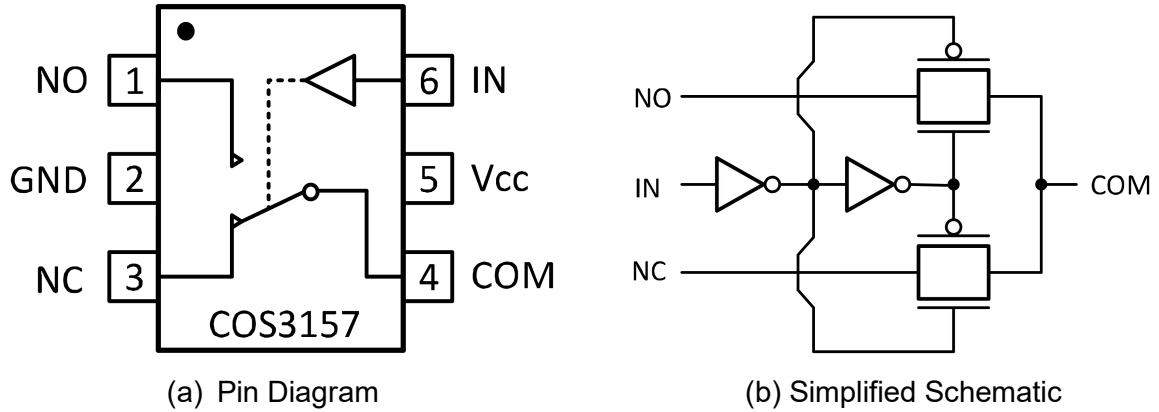

Truth Table

IN	NO	NC
0	OFF	ON
1	ON	OFF

Pin Description

PIN	NAME	FUNCTION
1	NO	Normally Open Terminal
2	GND	Ground
3	NC	Normally Closed Terminal
4	COM	Common Terminal
5	V _{CC}	Power supply
6	IN	Digital Control Pin, must be held HIGH or LOW

2. Package and Ordering Information

Order Number	Package	Package Option	Marking Information
COS3157ST	SOT23-6	Tape and Reel, 3000	C3157
COS3157SC	SC70-6 (SOT363)	Tape and Reel, 3000	C3157

3. Product Specification

3.1 Absolute Maximum Ratings ⁽¹⁾

Parameter	Min	Max	Unit
Supply voltage range (V_{CC})	-0.3	6.0	V
Analog voltage range (V_{NC}, V_{NO}, V_{COM})	-0.3	$V_{CC} + 0.3$	V
Digital input voltage range (V_{IN})	-0.3	6.0	V
Continuous current into any terminal	-50	50	mA
Peak current into any terminal	-80	80	mA
Operating junction temperature	-40	+125	°C
Storage temperature	-55	+150	°C
ESD (HBM)	-2000	+2000	V
ESD (MM)	-400	+400	V

(1) Stresses exceeding the absolute maximum ratings may damage the device. The device may not function or be operable above the recommended operating conditions and stressing the parts to these levels is not recommended. In addition, extended exposure to stresses above the recommended operating conditions may affect device reliability. The absolute maximum ratings are stress ratings only.

3.2 Thermal Data

Parameter	Rating	Unit
Package Thermal Resistance, $R_{\theta JA}$ (Junction-to-ambient)	190 (SOT23-6) 270 (SC70-6)	°C/W

3.3 Recommended Operating Conditions

Parameter	Min	Max	Unit
V_{CC}	1.65	5.5	V
V_{NC}, V_{NO}, V_{COM}	0	V_{CC}	
V_{IN}	0	V_{CC}	
T_A , Operating free-air temperature	-40	+85	°C

3.4 Electrical Characteristics

($V_{CC}=1.8V$ to $5.5V$, $T_A=-40^{\circ}C$ to $125^{\circ}C$, Typical values are at $V_{CC}=5.0V$, $T_A=+25^{\circ}C$, unless otherwise noted)

Parameter	Symbol	Conditions	Vcc	T _A	Min.	Typ.	Max.	Unit
Analog Switch								
Analog signal range	V _{IS}			FULL	0		V _{CC}	V
On-state resistance	R _{ON}	V _{NO} or V _{NC} = V _{CC} /2, I _{COM} = -10mA, Switch On, See Figure 1	5V	+25°C		4.5	8	Ω
				FULL			8.5	
			3.3V	+25°C		7	10	Ω
				FULL			10.5	
On-state resistance match between channels	ΔR _{ON}	V _{NO} or V _{NC} = V _{CC} /2, I _{COM} = -10mA, Switch On, See Figure 1	5V	+25°C		0.15	0.3	Ω
				FULL			0.4	
			3.3V	+25°C		0.15	0.3	Ω
				FULL			0.4	
On-state resistance flatness	R _{ON(flat)}	V _{NO} or V _{NC} = 0 to V _{CC} /2, I _{COM} = -10mA, Switch On, See Figure 1	5V	+25°C		2	3	Ω
				FULL			3.5	
			3.3V	+25°C		3	4	Ω
				FULL			4.5	
OFF-state leakage current	I _{NC(OFF)} I _{NO(OFF)}	V _{NO} or V _{NC} = 0.3V, V _{CC} /2, V _{COM} = V _{CC} /2, 0.3V, Switch OFF, See Figure 2	1.8V to 5.5V	FULL			1	μA
Channel ON leakage current	I _{NC(ON)} I _{NO(ON)} I _{COM(ON)}	V _{NO} or V _{NC} = 0.3V, V _{CC} /2, V _{COM} = 0.3V, V _{CC} /2, Switch ON, See Figure 3	1.8V to 5.5V	FULL			1	μA
Digital Control Input								
Input logic high	V _{IH}		5V	FULL	2.6			V
			3.3V	FULL	1.7			V
Input logic low	V _{IL}		5V	FULL			0.8	V
			3.3V	FULL			0.7	V
Input leakage current	I _{IH} , I _{IL}	V _{IN} = 0 or V _{IO}	1.8V to 5.5V	FULL			1	μA

Switch Dynamic Characteristics								
Turn-on time	t_{ON}	V_{NC} or $V_{NO} = V_{CC}$, $R_L = 300\Omega$, $C_L = 35pF$, See Figure 4	5V	+25°C		26		ns
			3.3V			30		
Turn-off time	t_{OFF}	V_{NC} or $V_{NO} = V_{CC}$, $R_L = 300\Omega$, $C_L = 35pF$, See Figure 4	5V	+25°C		8		ns
			3.3V			9		
Propagation delay	t_{PHL} t_{PLH}	$V_{IS} = 3V$, $R_L = 300\Omega$, $C_L = 35pF$, See Figure 5	5V	+25°C		1.4		ns
			3.3V			1.3		
Break-before-make delay	t_{BBM}	$V_{IS} = 3V$, $R_L = 300\Omega$, $C_L = 35pF$, See Figure 6	5V	+25°C		5		ns
			3.3V			8		
Charge injection	Q	$V_{GEN} = 0V$, $R_{GEN} = 0\Omega$, $C_L = 0.1nF$, See Figure 7	5V	+25°C		10		pC
			3.3V			3		
OFF-state capacitance	$C_{NC(OFF)}$ $C_{NO(OFF)}$	$V_{CC} = 3.3V$, $V_{I/O} = V_{CC}$ or 0, Switch OFF, See Figure 8		+25°C		6		pF
ON-state capacitance	$C_{NC(ON)}$ $C_{NO(ON)}$	$V_{CC} = 3.3V$, $V_{I/O} = V_{CC}$ or 0, Switch ON, See Figure 8		+25°C		15		pF
Digital input capacitance	C_I	$V_{CC} = 0V$, $V_{IN} = V_{CC}$ or 0, See Figure 8		+25°C		2		pF
OFF-isolation	V_{ISO}	$R_L = 50\Omega$, $C_L = 5pF$, $V_{I/O} = 0dBm$, $f = 1MHz$ Switch OFF, See Figure 9		+25°C		-70		dB
Crosstalk	X_{TALK}	$R_L = 50\Omega$, $C_L = 5pF$, $V_{I/O} = 0dBm$, $f = 1MHz$ Switch ON, See Figure 10		+25°C		-72		dB
Bandwidth	BW	$R_L = 50\Omega$, $C_L = 5pF$, $V_{I/O} = 0dBm$, $f = 1MHz$ Switch ON, See Figure 11		+25°C		300		MHz
Power Supply								
V_{CC} supply range	V_{CC}			FULL	1.65		5.5	V
V_{CC} supply current	I_{CC}	$I_{I/O} = 0$, Switch ON or OFF	5.5V	FULL			5	μA

4. Test Circuits and Timing Diagrams

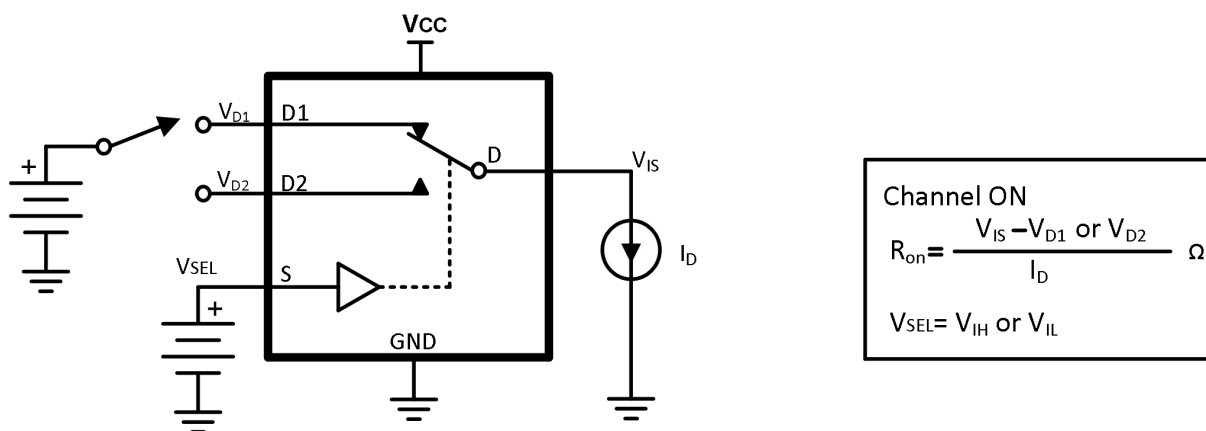

Figure 1. ON-State Resistance (RON)

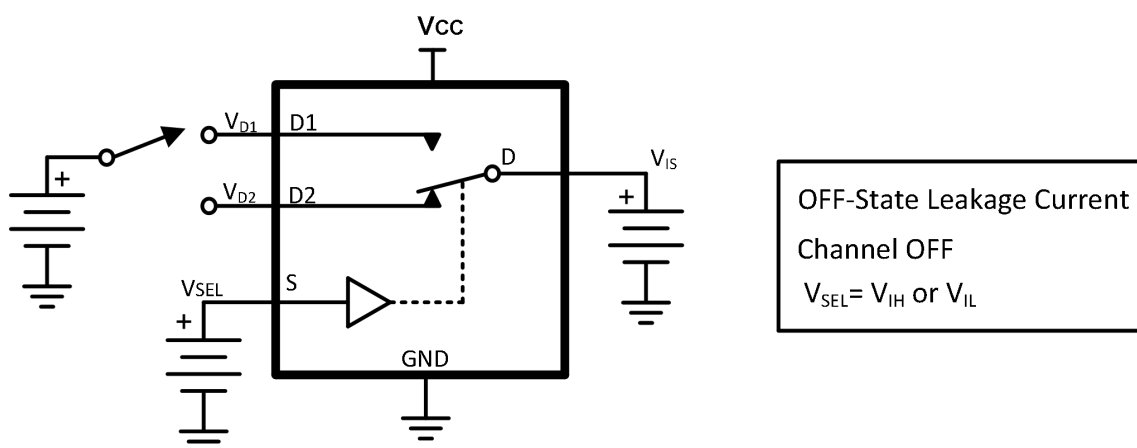

Figure 2. OFF-State Leakage Current

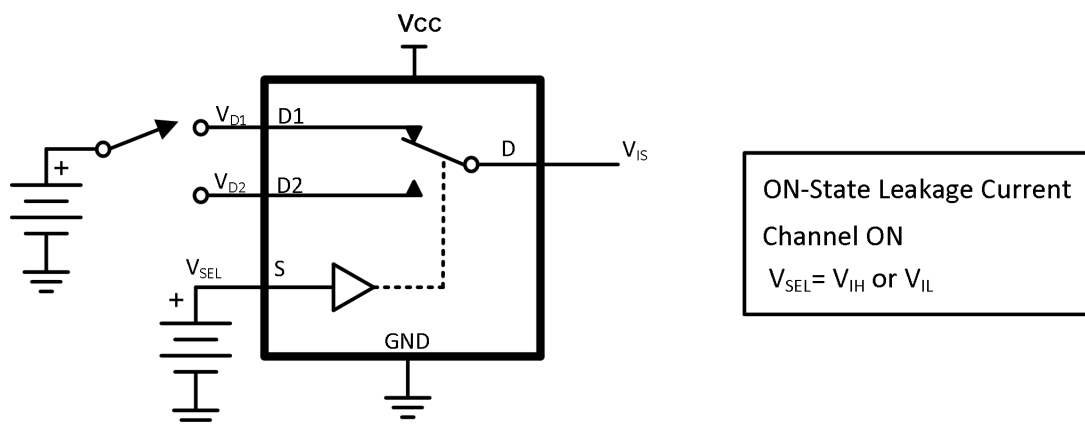

Figure 3. ON-State Leakage Current

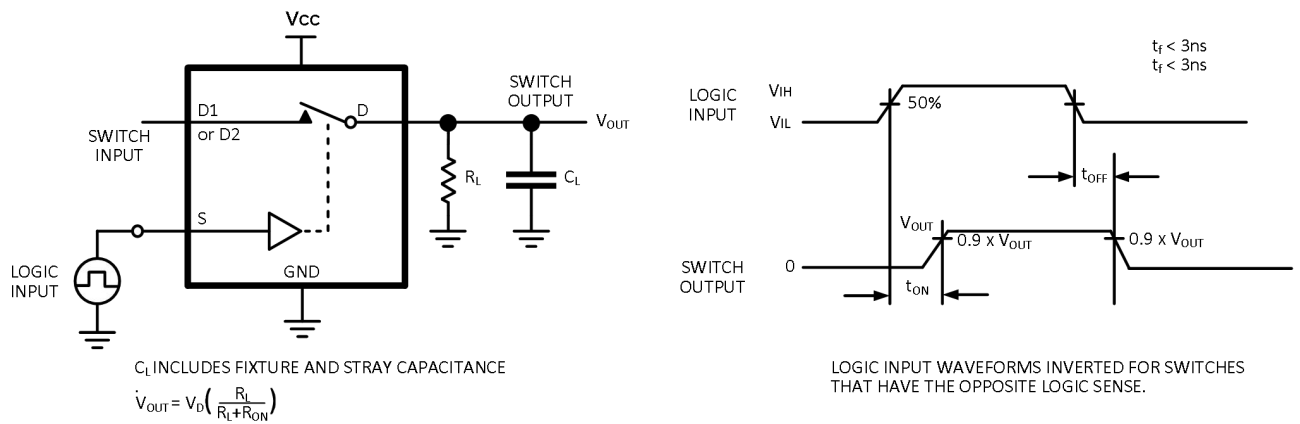

Figure 4. Turn-On (T_{ON}) and Turn-Off Time (T_{OFF})

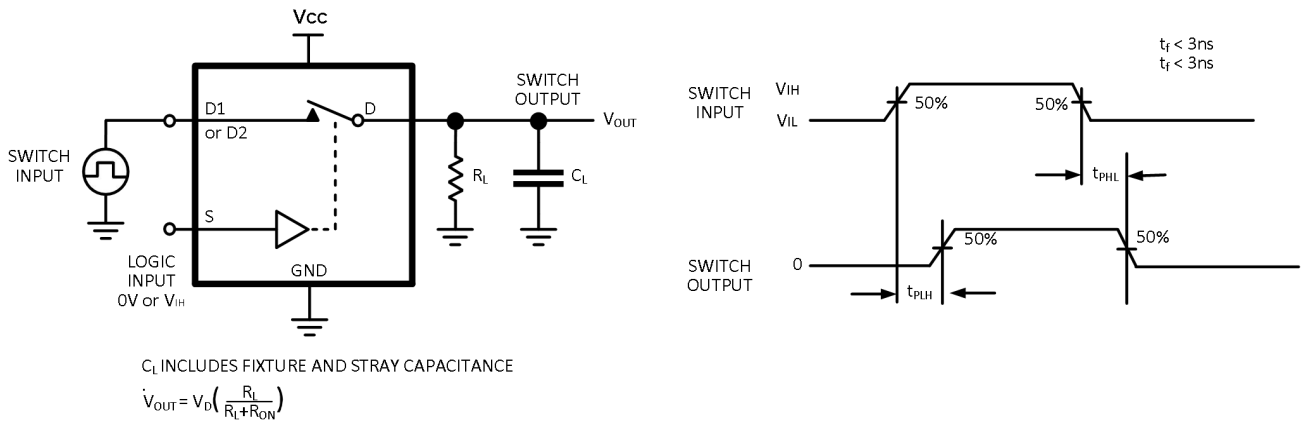

Figure 5. Propagation Delay

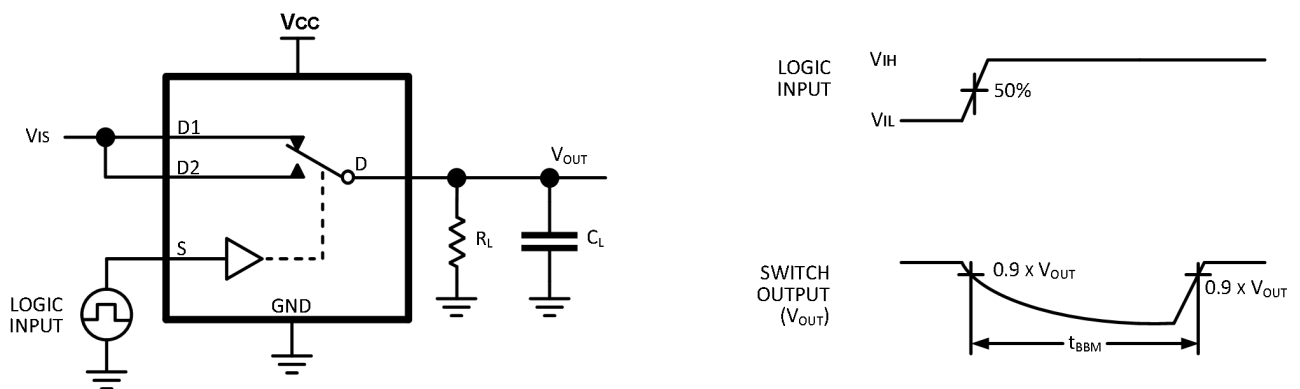

Figure 6. Break-Before-Make Time (T_{BMM})

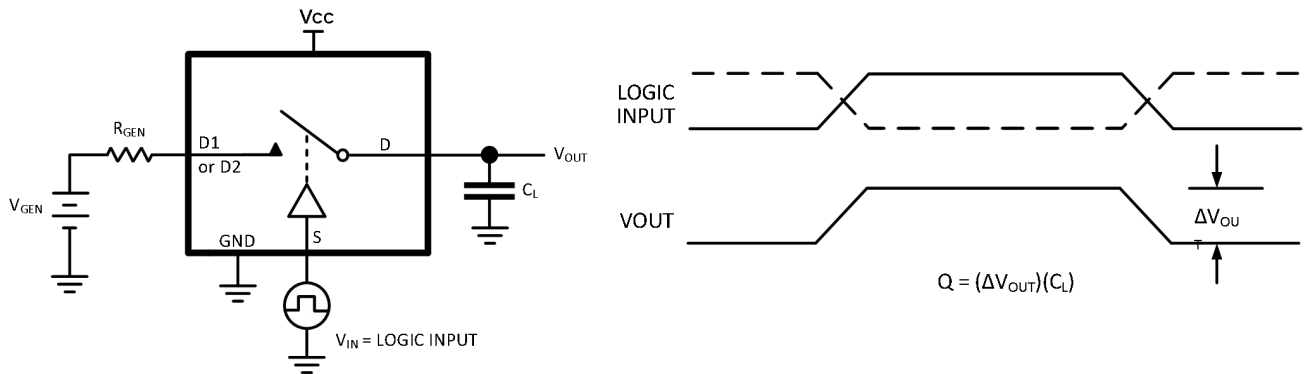

Figure 7. Charge Injection (Q_c)

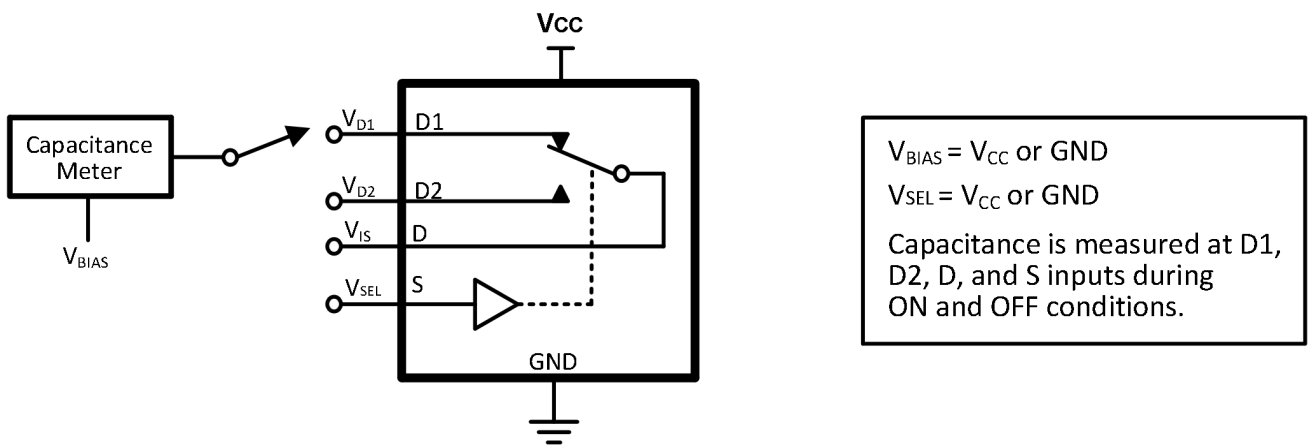

Figure 8. Capacitance

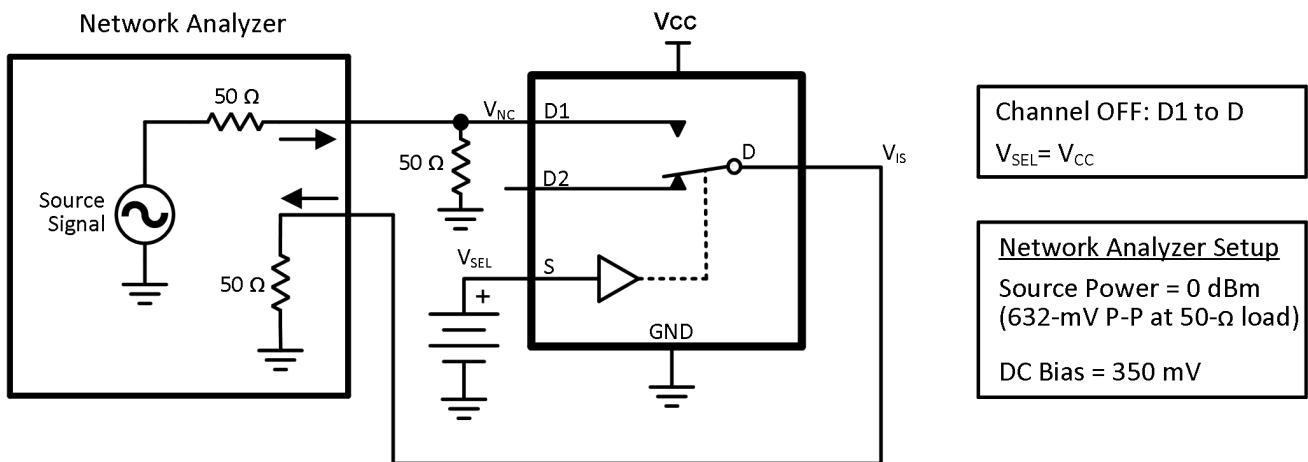

Figure 9. OFF Isolation (O_{iso})

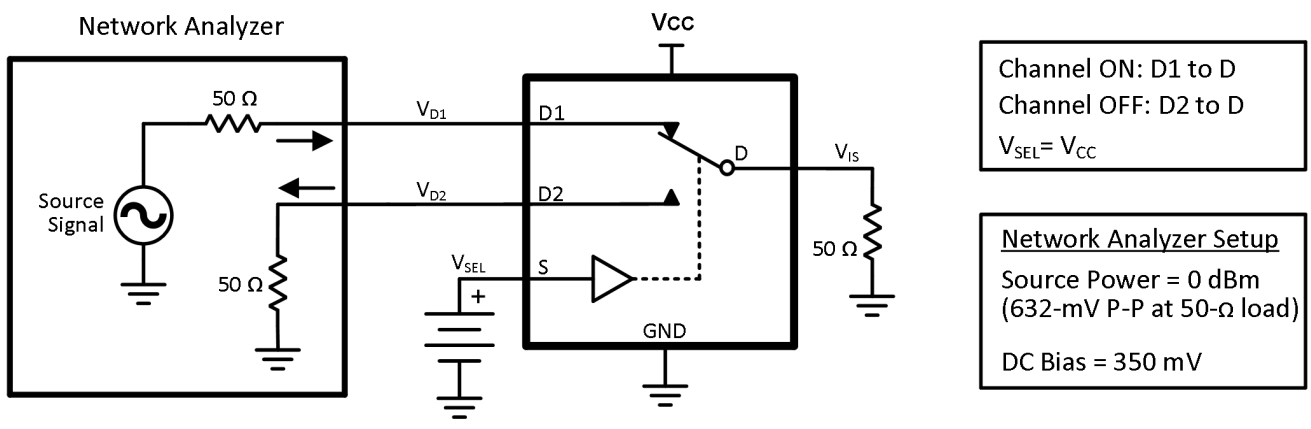

Figure 10. Crosstalk (X_{TALK})

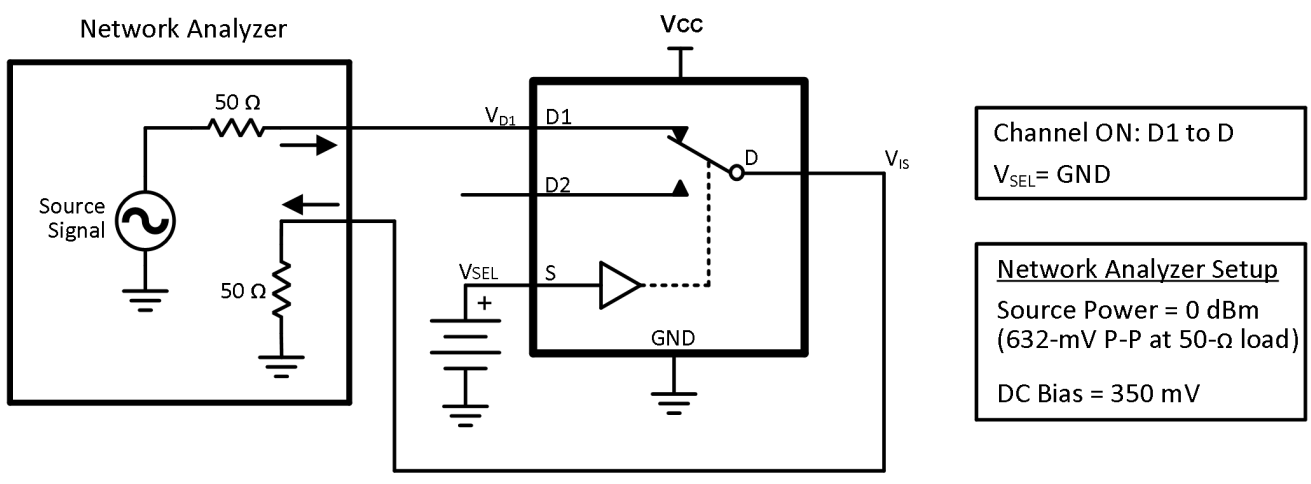
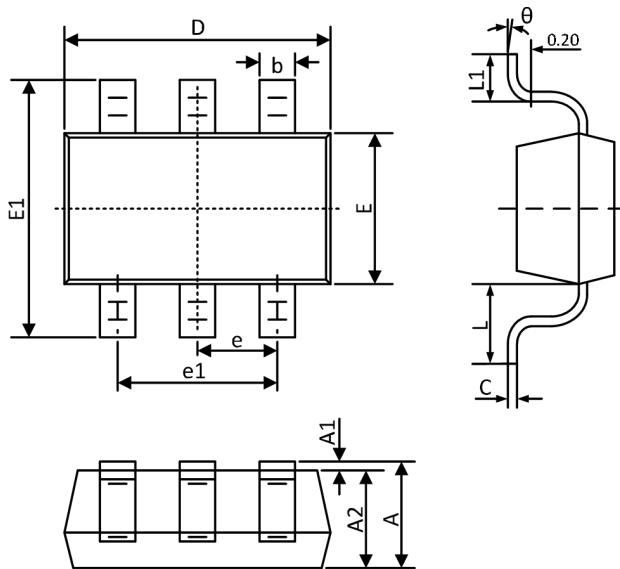

Figure 11. Bandwidth (BW)

5. Package Information

5.1 SOT23-6 (Package Outline Dimensions)



Symbol	Dimensions In Millimeters		Dimensions In Inches	
	MIN	MAX	MIN	MAX
A	1.050	1.250	0.041	0.049
A1	0.000	0.100	0.000	0.004
A2	1.050	1.150	0.041	0.045
b	0.300	0.400	0.012	0.016
c	0.100	0.200	0.004	0.008
D	2.820	3.020	0.111	0.119
E	1.500	1.700	0.059	0.067
E1	2.650	2.950	0.104	0.116
e	0.950TYP		0.037TYP	
e1	1.800	2.000	0.071	0.079
L	0.700REF		0.028REF	
L1	0.300	0.600	0.012	0.024
θ	0°	8°	0°	8°

5.2 SC70-6 / SOT363 (Package Outline Dimensions)

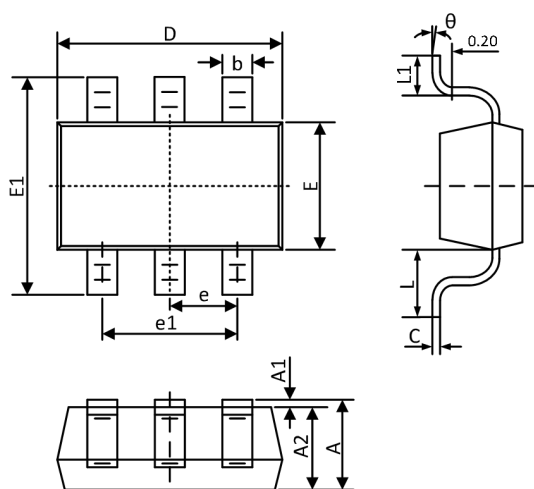

Symbol	Dimensions In Millimeters		Dimensions In Inches	
	MIN	MAX	MIN	MAX
A	0.900	1.100	0.035	0.043
A1	0.000	0.100	0.000	0.004
A2	0.900	1.000	0.035	0.039
b	0.150	0.350	0.006	0.014
c	0.080	0.150	0.003	0.006
D	2.000	2.200	0.079	0.087
E	1.150	1.350	0.045	0.053
E1	2.150	2.450	0.085	0.096
e	0.65 TYP		0.026 TYP	
e1	1.300 BSC		0.051 BSC	
L	0.525 REF		0.021 REF	
L1	0.260	0.460	0.010	0.018
θ	0°	8°	0°	8°