



BMx65N380C1

N-Channel Planar MOSFET

650 V, 10.5 A, 380 mΩ

Description

BMx65N380C1 is power MOSFET using bestirpower's advanced super junction technology that can realize very low on-resistance and gate charge. It will provide much high efficiency by using optimized charge coupling technology. These user friendly devices give an advantage of Low EMI to designers as well as low switching loss.

Features

$BV_{DSS, Tc=25^{\circ}C}$	$I_D, Tc=25^{\circ}C$	$R_{DS(on),max. Tc=25^{\circ}C}$	$Q_{g,typ}$
650 V	10.5 A	380 mΩ	23.5 nC

- Ultra-fast body diode.
- Extremely low losses due to very low FOM $R_{dson} * Q_g$ and E_{oss} .
- Very high commutation ruggedness.

TO-220

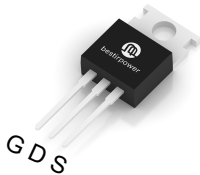

TO-220F

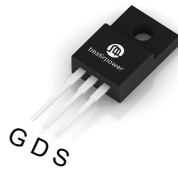

TO-252

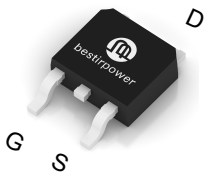

TO-263

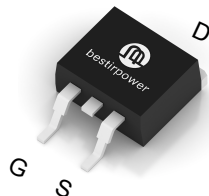

Applications

- PFC.
- Adapter.
- LCD TV.
- LED lighting.
- UPS.

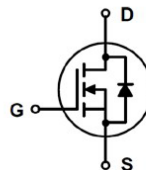

Package Marking and Ordering Information

Part Number	Top Marking	Package	Packing Method
BMP65N380C1	BMP65N380C1	TO220	Tube
BMF65N380C1	BMF65N380C1	TO220F	Tube
BMB65N380C1	BMB65N380C1	TO263	Tape & Reel
BMD65N380C1	BMD65N380C1	TO252	Tape & Reel

Absolute Maximum Ratings ($T_C = 25^\circ\text{C}$ unless otherwise noted)

Symbol	Parameter	Value	Unit
V_{DSS}	Drain to Source Voltage	650	V
V_{GSS}	Gate to Source Voltage	± 30	V
I_D	Drain Current ¹⁾	Continuous ($T_C = 25^\circ\text{C}$)	10.5
		Continuous ($T_C = 125^\circ\text{C}$)	4.7
I_{DM}	Drain Current	Pulsed	31
P_D	Power Dissipation For TO-220F	32	W
	Power Dissipation For TO-220, TO-252, TO-263	104.2	
E_{AS}	Single Pulsed Avalanche Energy ²⁾	225	mJ
dv/dt	Diode Recovery dv/dt ³⁾	15	V/ns
I_S	Continuous diode forward current $T_C = 25^\circ\text{C}$	10.5	A
$I_{S,pulse}$	Diode pulse current ¹⁾	31	A
T_{STG}	Storage Temperature Range	-55 to 150	$^\circ\text{C}$
T_J	Maximum Operating Junction Temperature	150	$^\circ\text{C}$
T_L	Maximum Lead Temperature for Soldering, 1/8" from Case for 10	260	$^\circ\text{C}$

1) Pulse width t_p limited by $T_{j,max}$.

2) $V_{DD} = 50\text{V}$, $R_G = 25\Omega$, Starting $T_j = 25^\circ\text{C}$.

3) $V_{DClink} = 400\text{V}$; $V_{DS,peak} < V_{(BR)DSS}$; identical low side and high side switch with identical R_G .

Thermal Characteristics (FullPAK) TO220F

Symbol	Parameter	Value	Unit
$R_{\theta JC}$	Thermal Resistance, Junction to Case	3.9	$^\circ\text{C/W}$
$R_{\theta JA}$	Thermal Resistance, Junction to Ambient	62.5	

Thermal Characteristics (Non FullPAK) TO220, TO252, TO263

Symbol	Parameter	Value	Unit
$R_{\theta JC}$	Thermal Resistance, Junction to Case	1.2	$^\circ\text{C/W}$
$R_{\theta JA}$	Thermal Resistance, Junction to Ambient	62	

Electrical Characteristics ($T_J = 25^\circ\text{C}$ unless otherwise noted)

Symbol	Parameter	Test Conditions	Min	Typ	Max	Unit
--------	-----------	-----------------	-----	-----	-----	------

Off Characteristics

BV_{DSS}	Drain to Source Breakdown Voltage	$V_{GS} = 0\text{ V}, I_D = 250\mu\text{A}$	650	-	-	V
I_{DSS}	Zero Gate Voltage Drain Current	$V_{DS} = 650\text{ V}, V_{GS} = 0\text{ V}, T_J = 25^\circ\text{C}$	-	-	1	μA
I_{GSS}	Gate-Source Leakage Current	$V_{GS} = \pm 20\text{ V}, V_{DS} = 0\text{ V}$	-	-	± 100	nA

On Characteristics

$V_{GS(th)}$	Gate Threshold Voltage	$V_{GS} = V_{DS}, I_D = 250\mu\text{A}$	2.0	3.0	4.0	V
$R_{DS(on)}$	Static Drain to Source On Resistance	$V_{GS} = 10\text{ V}, I_D = 5.5\text{ A}, T_J = 25^\circ\text{C}$	-	340	380	mΩ
R_G	Gate Resistance	$V_{DD} = 0\text{ V}, V_{GS} = 0\text{ V}, f = 1.0\text{ MHz}$	-	4	-	Ω

Dynamic Characteristics

C_{iss}	Input Capacitance	$V_{GS} = 0\text{ V}, V_{DS} = 50\text{ V}, f = 1\text{ MHz}$	-	630	-	pF
C_{oss}	Output Capacitance		-	33	-	pF
C_{riss}	Reverse Transfer Capacitance		-	1.4	-	pF
$C_{o(er)}$	Effective output capacitance, energy related ¹⁾	$V_{GS} = 0\text{ V}, V_{DS} = 0\text{ to }400\text{ V}$	-	25	-	pF
$C_{o(tr)}$	Effective output capacitance, time related ²⁾		-	128	-	pF
Q_g	Total Gate Charge	$V_{GS} = 0\text{ to }10\text{ V}, V_{DD} = 480\text{ V}, I_D = 5\text{ A}$	-	23.5	-	nC
Q_{gs}	Gate to Source Charge		-	2.5	-	nC
Q_{gd}	Gate to Drain "Miller" Charge		-	9	-	nC
$V_{plateau}$	Gate plateau voltage		-	5	-	V

Switching Characteristics

$t_{d(on)}$	Turn-On Delay Time	$V_{DD} = 480\text{ V}, I_D = 5\text{ A}, V_{GS} = 0\text{ to }10\text{ V}$	-	57	-	ns
t_r	Turn-On Rise Time		-	30	-	ns
$t_{d(off)}$	Turn-Off Delay Time		-	73	-	ns
t_f	Turn-Off Fall Time		-	15	-	ns

Reverse Diode Characteristics

V_{SD}	Diode Forward Voltage	$I_F = 5.5\text{ A}, V_{GS} = 0\text{ V}, T_J = 25^\circ\text{C}$	-	0.85	-	V
t_{rr}	Reverse Recovery Time	$V_R = 480\text{ V}, I_F = 5\text{ A}, di_F/dt = 100\text{ A}/\mu\text{s}$	-	210	-	ns
Q_{rr}	Reverse Recovery Charge		-	1.29	-	μC
I_{rm}	Peak Reverse Recovery Current		-	16	-	A

1) $C_{o(er)}$ is a fixed capacitance that gives the same stored energy as C_{oss} while V_{DS} is rising from 0 to 400V.

2) $C_{o(tr)}$ is a fixed capacitance that gives the same charging time as C_{oss} while V_{DS} is rising from 0 to 400V.

Typical Performance Characteristics

Figure 1: Transient Thermal Impedance For TO-220F

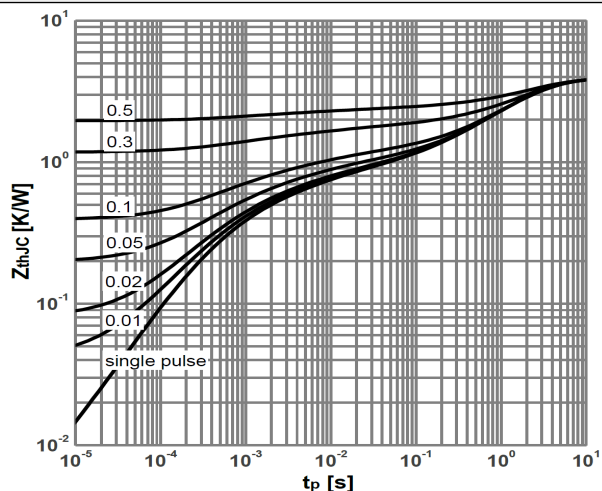

Figure 2: Power dissipation For TO-220F

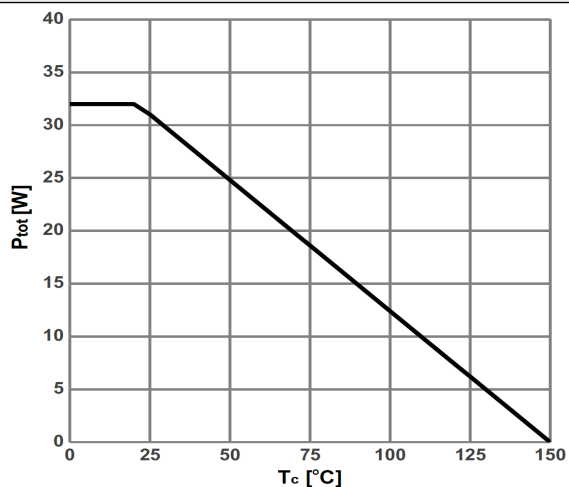

Figure 3. Transient Thermal Impedance For TO-220、TO-252、TO-263

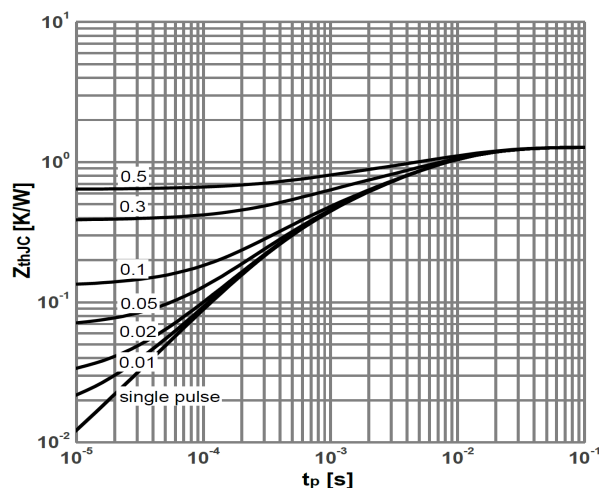

Figure 4. Power dissipation For TO-220、TO-252、TO-263

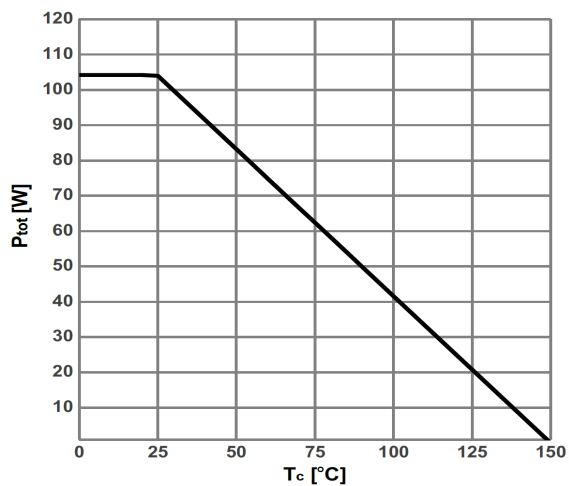

Figure 5: Safe operating area For TO-220、TO-252、TO-263

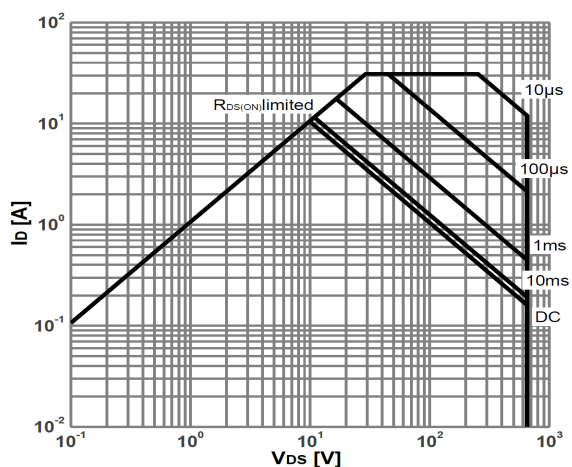
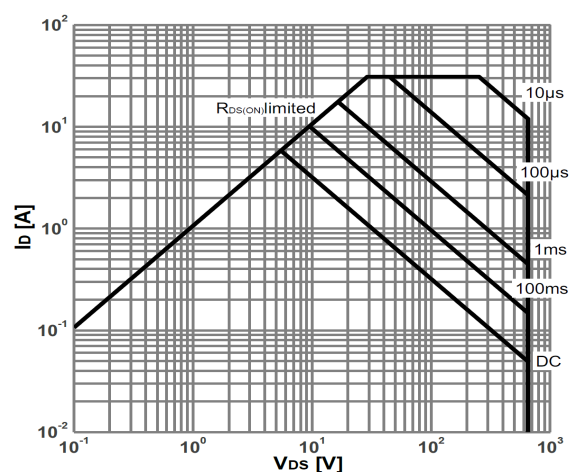

Figure 6: Safe operating area For TO-220F



Typical Performance Characteristics

Figure 7: Typ. output characteristics @ $T_j=25^\circ\text{C}$

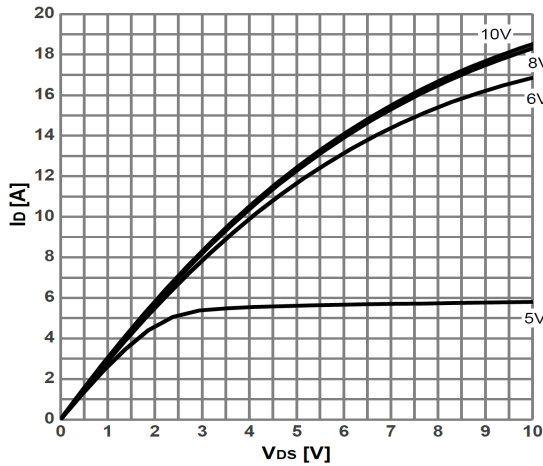

Figure 8: Typ. output characteristics @ $T_j=125^\circ\text{C}$

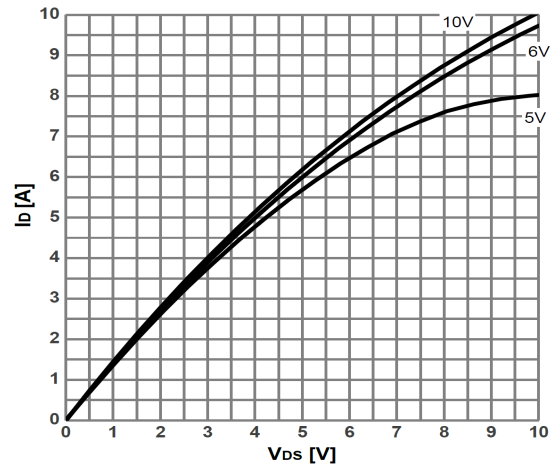

Figure 9: Typ. drain-source on-state resistance

$R_{DS(on)}=f(I_D)$; $T_j=25^\circ\text{C}$; parameter: V_{GS}

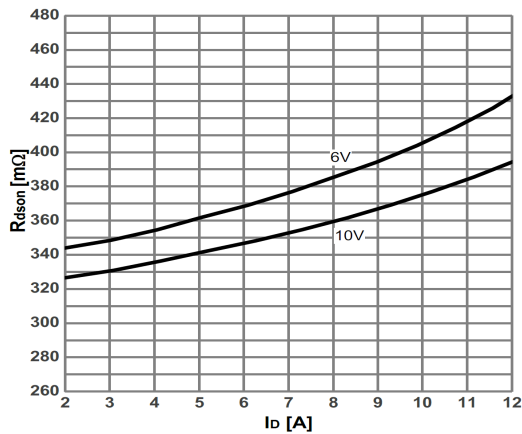

Figure 10: Drain-source on-state resistance

$R_{DS(on)}=f(T_j)$; $I_D=5.5\text{A}$; $V_{GS}=10\text{V}$

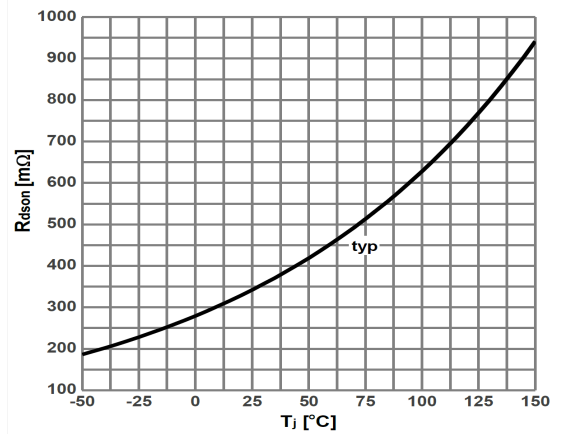

Figure 11: Typ. transfer characteristics

$I_D=f(V_{GS})$; $V_{DS}=20\text{V}$; parameter: T_j

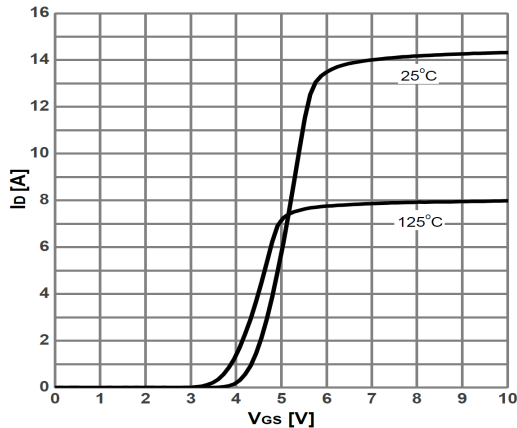
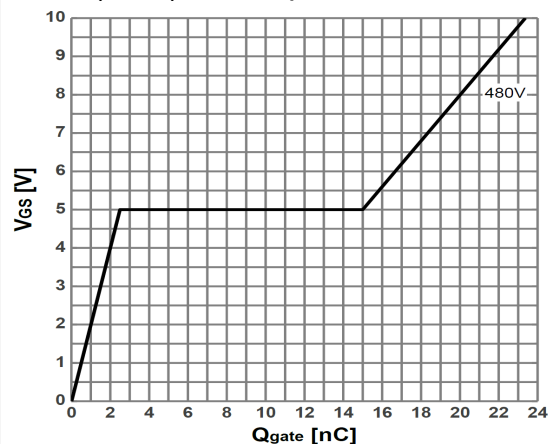

Figure 12: Typ. gate charge

$V_{GS}=f(Q_{gate})$; $I_D=5\text{A}$ pulsed; $V_{DS}=480\text{V}$



Typical Performance Characteristics

Figure 13: Forward characteristics of reverse diode

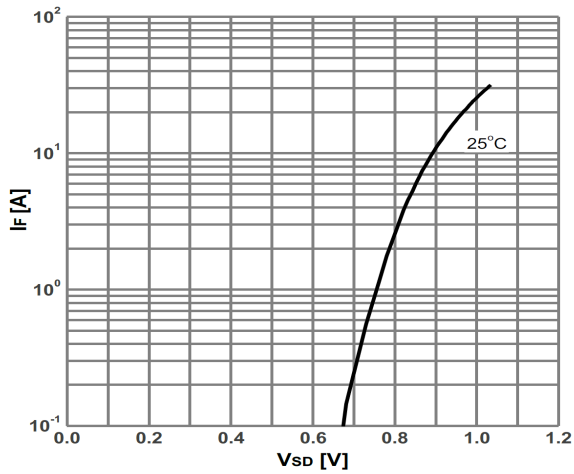

Figure 14: Drain-source breakdown voltage

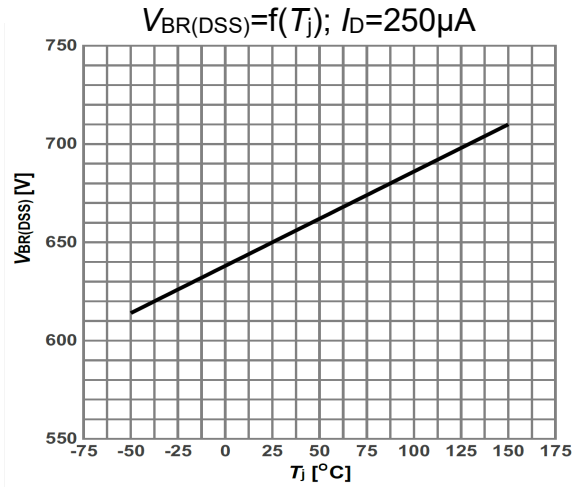

Figure 15: Typ. capacitances

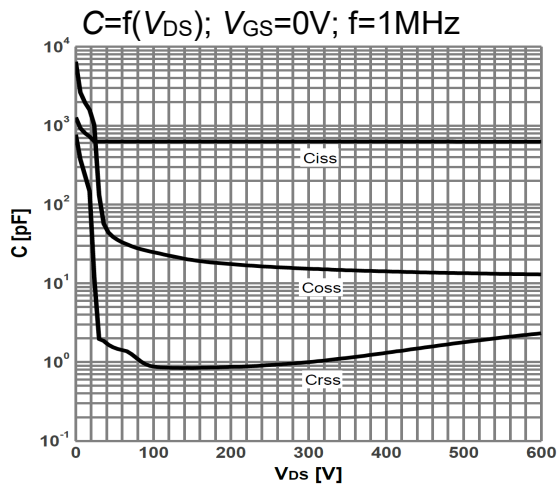
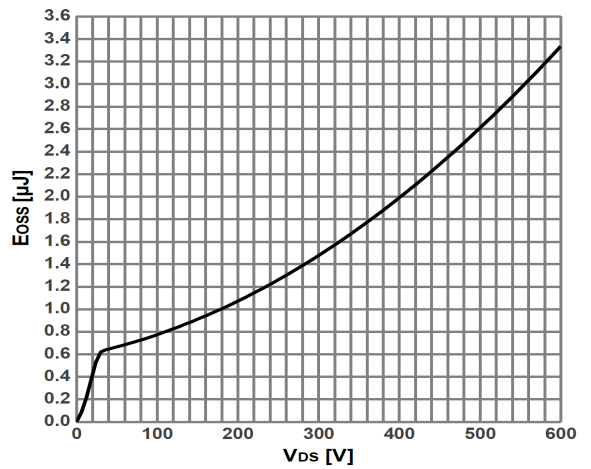

Figure 16: Typ. Coss stored energy



Test Circuits

Figure 17. Diode Characteristics

Test circuit for diode characteristics and Diode recovery waveform

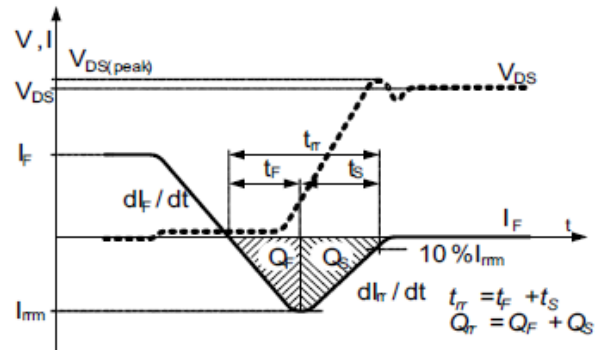
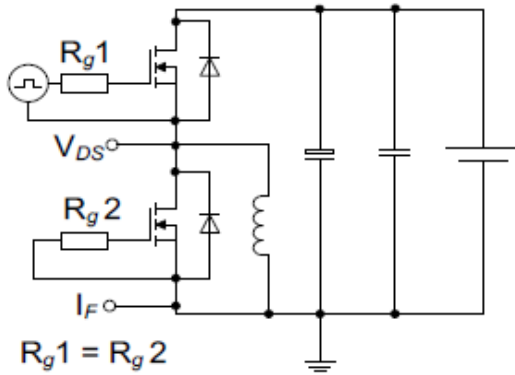

Figure 18. Switching Times

Switching times test circuit for inductive load and Switching times waveform

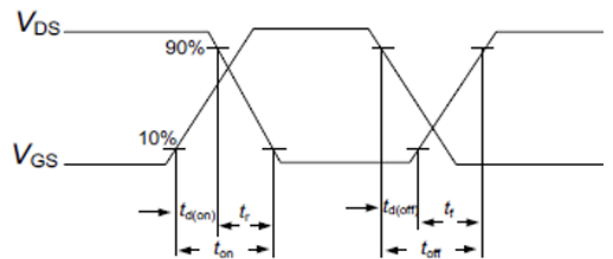
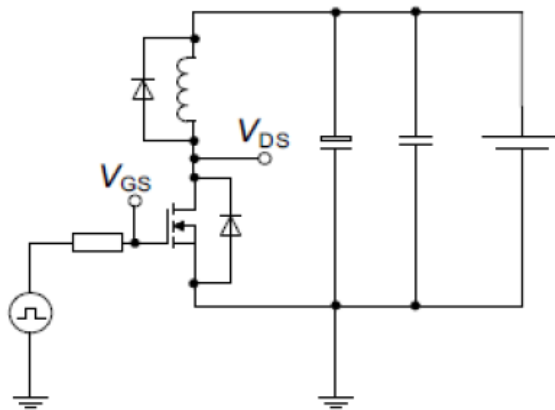
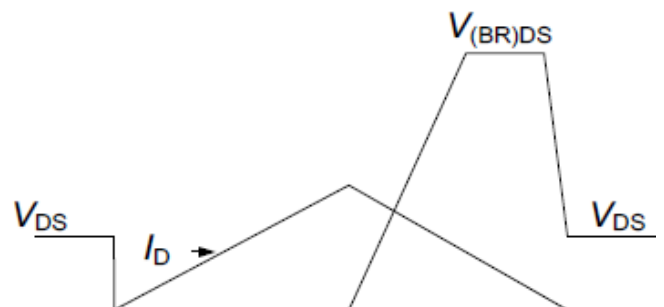
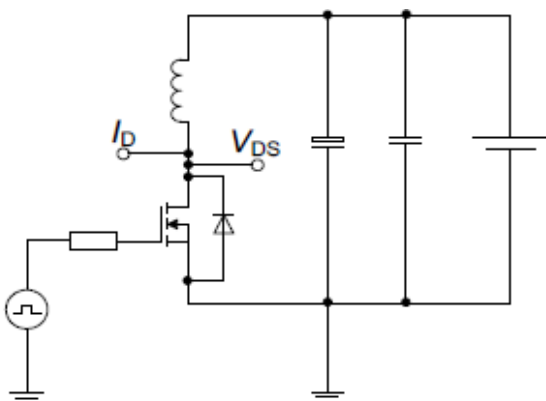

Figure 29. Unclamped Inductive Load

Unclamped inductive load test circuit and Unclamped inductive waveform



Package Outlines

TO-220

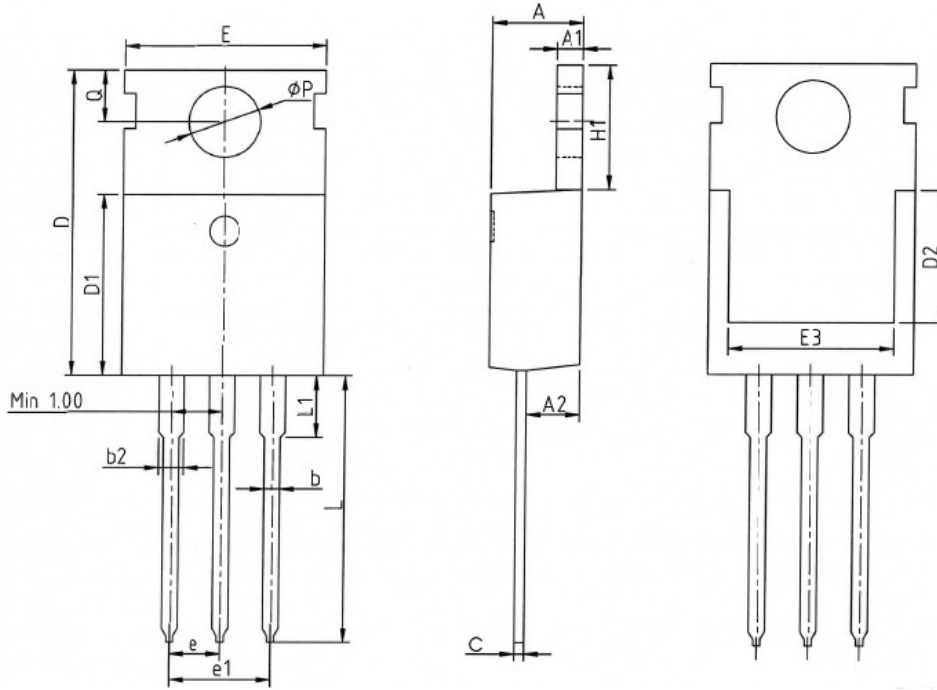

SYMBOL	MIN	NOM	MAX
A	4.37	4.57	4.70
A1	1.25	1.30	1.40
A2	2.20	2.40	2.60
b	0.70	0.80	0.95
b2	1.17	1.27	1.47
c	0.45	0.50	0.60
D	15.10	15.60	16.10
D1	8.80	9.10	9.40
D2	5.50	6.30	7.10
E	9.70	10.00	10.30
E3	7.00	7.80	8.60
e	2.54 BSC		
e1	5.08 BSC		
H1	6.25	6.50	6.85
L	12.75	13.50	13.80
L1	-	3.10	3.40
ΦP	3.40	3.60	3.80
Q	2.60	2.80	3.00

* Dimensions in millimeters

Package Outlines

TO-220F

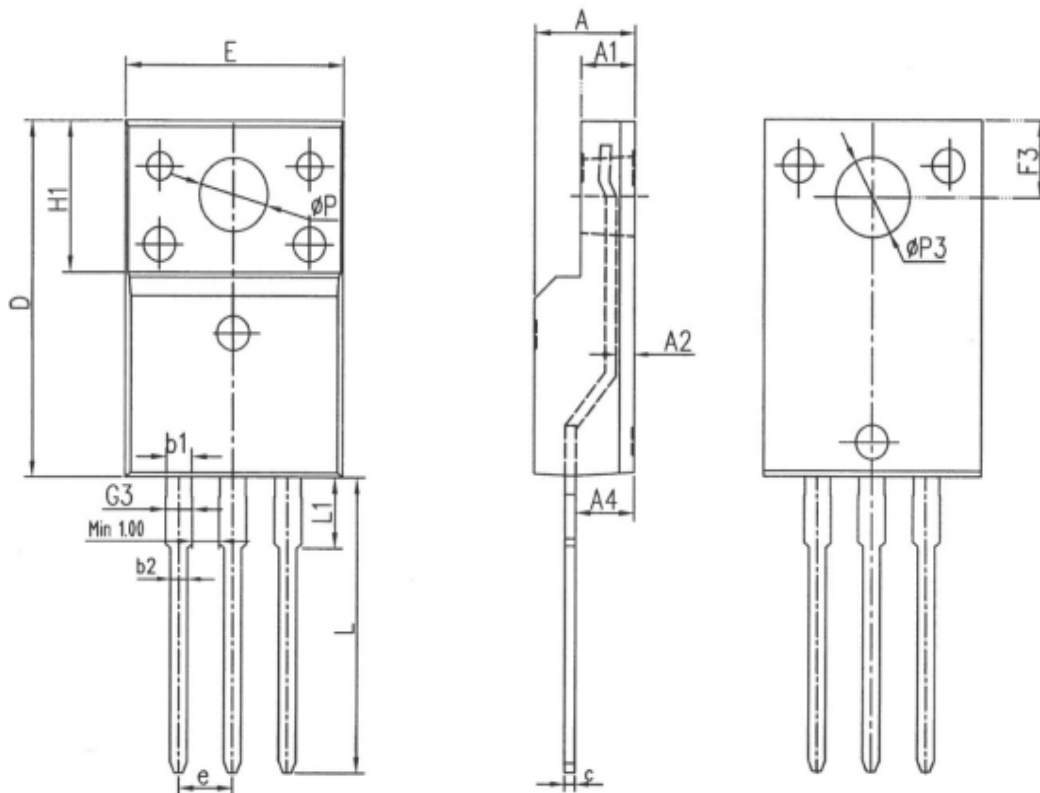

COMMON DIMENSIONS

SYMBOL	MM		
	MIN	NOM	MAX
E	10.00	10.20	10.40
A	4.50	4.70	4.90
A1	2.34	2.54	2.74
A2	0.65	0.85	1.30
A4	2.55	2.75	2.95
c	0.40	0.50	0.65
D	15.57	15.87	16.17
H1	6.70REF		
e	2.54BSC		
ΦP	3.183REF		
L	12.68	12.98	13.28
L1	3.25	3.45	3.65
ΦP3	3.45REF		
F3	3.10	3.30	3.50
G3	1.10	1.30	1.50
b1	1.05	1.20	1.35
b2	0.70	0.80	0.92

* Dimensions in millimeters

Package Outlines

TO-252

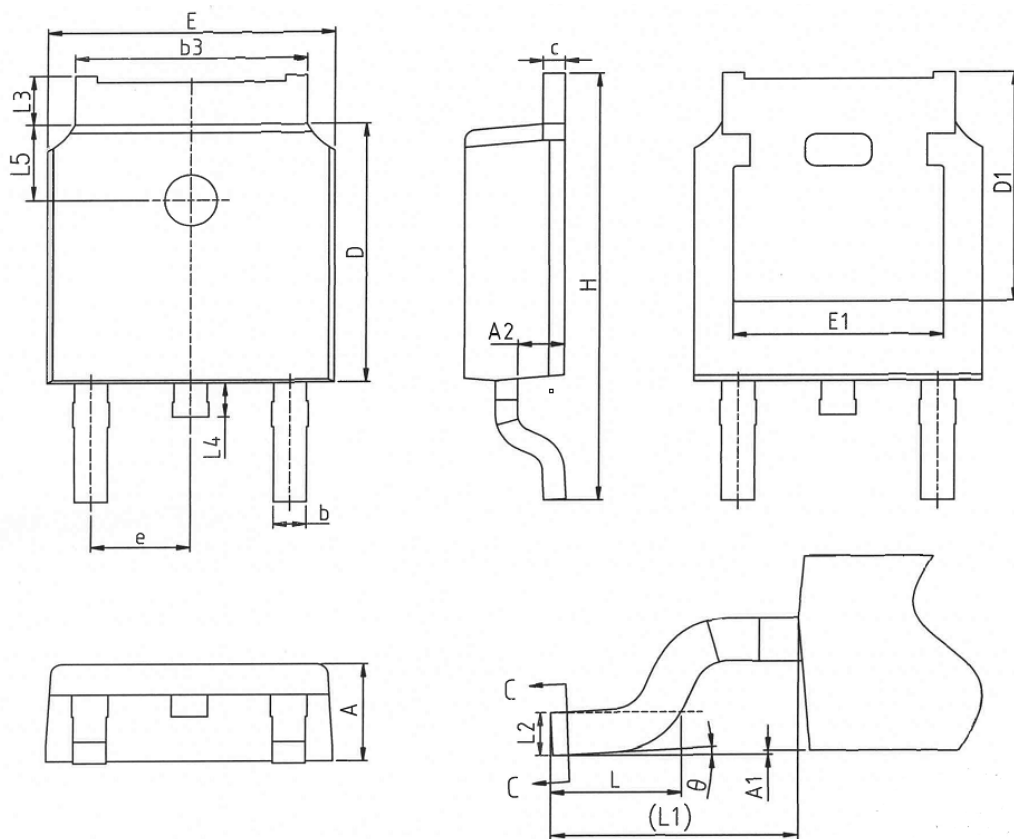

COMMON DIMENSIONS

SYMBOL	mm		
	MIN	NOM	MAX
A	2.20	2.30	2.38
A1	0.00	-	0.12
A2	0.97	1.07	1.17
b	0.68	0.78	0.90
b3	5.20	5.33	5.46
c	0.43	0.53	0.61
D	5.98	6.10	6.22
D1	5.30REF		
E	6.40	6.60	6.73
E1	4.63	-	-
e	2.286BSC		
H	9.40	10.10	10.50
L	1.38	1.50	1.75
L1	2.90REF		
L2	0.51BSC		
L3	0.88	-	1.28
L4	0.50	-	1.00
L5	1.65	1.80	1.95
θ	0°	-	8°

* Dimensions in millimeters

Package Outlines

TO-263

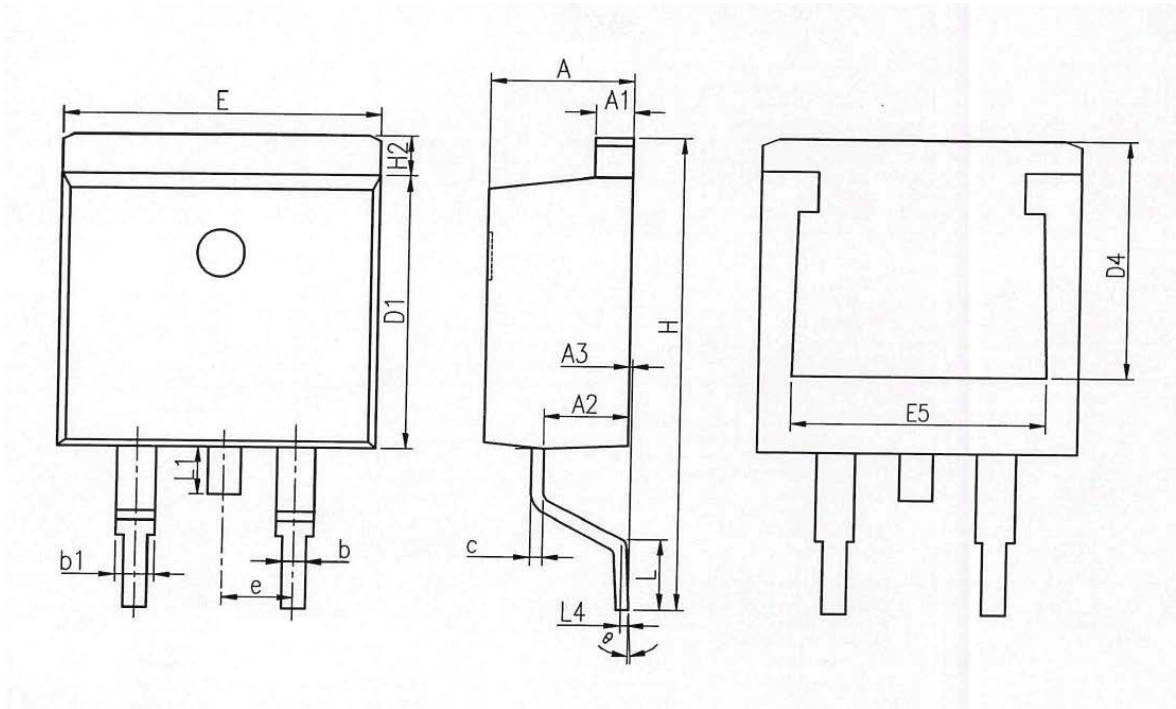

COMMON DIMENSIONS

SYMBOL	MM		
	MIN	NOM	MAX
A	4.37	4.57	4.77
A1	1.22	1.27	1.42
A2	2.49	2.69	2.89
A3	0.00	0.13	0.25
b	0.70	0.81	0.96
b1	1.17	1.27	1.47
c	0.30	0.38	0.53
D1	8.50	8.70	8.90
D4	6.60	-	-
E	9.86	10.16	10.36
E5	7.06	-	-
e	2.54 BSC		
H	14.70	15.10	15.50
H2	1.07	1.27	1.47
L	2.00	2.30	2.60
L1	1.40	1.55	1.70
L4	0.25 BSC		
θ	0°	5°	9°

* Dimensions in millimeters

Disclaimer

Bestirpower reserve the right to make changes, corrections, enhancements, modifications, and improvements to Bestirpower products and/or to this document at any time without notice.

The information given in this document shall in no event be regarded as a guarantee of conditions or characteristics. Bestirpower does not assume any liability for infringement of patents, copyrights, or other intellectual property rights of third parties by or arising from the use of Products or technical information described in this document.

This document is the property of Bestirpower Co., LTD., and not allowed to copy or transformed to other format if not under the authority approval.

© 2024 bestirpower – All rights reserved