

AFE58JD28 16-Channel Ultrasound AFE with 102-mW/Channel Power, 0.8-nV/ $\sqrt{\text{Hz}}$ Noise, 14-Bit, 65-MSPS or 12-Bit, 80-MSPS ADC, Digital Demodulator, JESD or LVDS Interface, and Passive CW Mixer

1 Features

- 16-Channel AFE for Ultrasound Applications:
 - Optimized Signal Chains for TGC and CW Modes
 - Four Programmable TGC Profiles
- Low-Noise Amplifier (LNA) With:
 - Programmable Gain: 21 dB, 18 dB, and 15 dB
 - Linear Input Signal Amplitude: 0.37 V_{PP}, 0.5 V_{PP}, and 0.71 V_{PP}
 - Active Termination
- Voltage-Controlled Attenuator (VCAT):
 - Attenuation Range: 0 dB–36 dB
- Programmable Gain Amplifier (PGA):
 - 18 dB–27 dB in Steps of 3 dB
- 3rd-Order, Linear-Phase, Low-Pass Filter (LPF):
 - Cutoff Frequency From 10 MHz to 30 MHz
- ADC Modes (Idle-Channel SNR):
 - 14-Bit, 65-MSPS Mode: 75-dBFS
 - 12-Bit, 80-MSPS Mode: 72-dBFS
- Optimized for Noise and Power:
 - TGC Mode: 102 mW/Ch at 0.8 nV/ $\sqrt{\text{Hz}}$, 65-MSPS, 14-Bit Output
 - CW Mode: 63 mW/Ch
- Excellent Device-to-Device Gain Matching:
 - ± 0.4 dB (Typical)
- Fast and Consistent Overload Recovery
- Continuous Wave (CW) Path With:
 - Low Close-In Phase Noise of -159 dBc/Hz at 1-kHz Frequency Offset off 2.5-MHz Carrier

- Phase Resolution: $\lambda / 16$
- Supports 16x and 8x CW Clocks
- 12-dB Suppression of 3rd and 5th Harmonics
- Digital I/Q Demodulator:
 - Fractional Decimation Filter M = 1 to 63 With Increments of 0.25
 - Data Throughput Reduction After Decimation
 - On-Chip RAM With 32 Preset Profiles
- LVDS Interface With a Speed Up to 1 Gbps
- 5-Gbps JESD Interface:
 - JESD204B Subclass 0, 1, and 2
 - 2, 4, or 8 Channels per JESD Lane
- Small Package: 15-mm x 15-mm NFBGA-289

2 Applications

- Medical Ultrasound Imaging
- Nondestructive Evaluation Equipment
- Sonar Imaging Equipment

3 Description

The AFE58JD28 device is a highly-integrated, analog front-end (AFE) solutions specifically designed for ultrasound systems where high performance, low power, and small size are required.

Device Information⁽¹⁾

| PART NUMBER | PACKAGE | BODY SIZE (NOM) |
|-------------|-------------|---------------------|
| AFE58JD28 | nFBGA (289) | 15.00 mm x 15.00 mm |

(1) For all available packages, see the package option addendum at the end of the datasheet.

Simplified Block Diagram

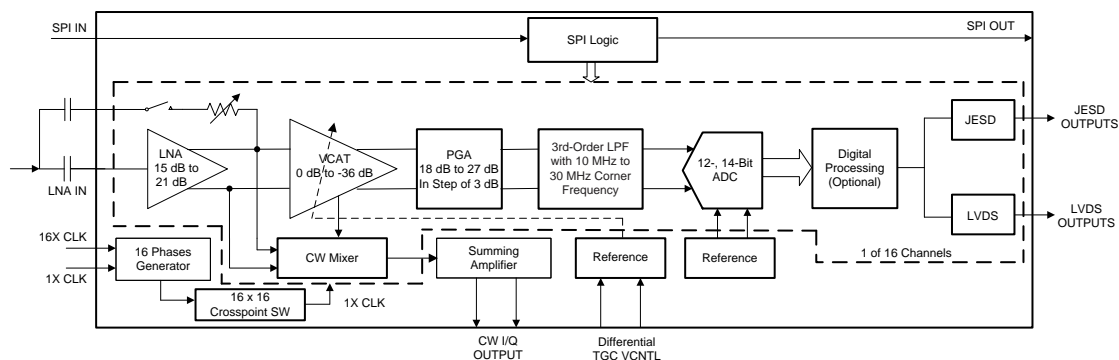

4 Description (continued)

The AFE58JD28 is an integrated AFE optimized for medical ultrasound application. The device is realized through a multichip module (MCM) with two dies: one voltage-controlled amplifier (VCA) die and one analog-to-digital converter (ADC) die. The VCA die has 16 channels that interface with the 16 channels of the ADC die.

Each channel in the VCA die can be configured in one of two modes: time gain compensation (TGC) mode or continuous wave (CW) mode. In TGC mode, each channel includes a low-noise amplifier (LNA), a voltage-controlled attenuator (VCAT), a programmable gain amplifier (PGA), and a third-order, low-pass filter (LPF). The LNA is programmable in gains of 21 dB, 18 dB, or 15 dB. The LNA also supports active termination. The VCAT supports an attenuation range of 0 dB to 36 dB, with analog voltage control for the attenuation. The PGA provides gain options from 18 dB to 27 dB in steps of 3 dB. The LPF cutoff frequency can be set between 10 MHz and 30 MHz to support ultrasound applications with different frequencies. In CW mode, the output of the LNA goes to a low-power passive mixer with 16 selectable phase delays followed by a summing amplifier with a band-pass filter. Different phase delays can be applied to each analog input signal to perform an on-chip beamforming operation. A harmonic filter in the CW mixer suppresses the third and fifth harmonic to enhance the sensitivity of the CW Doppler measurement.

The 16 channels of the ADC die can be configured to operate with a resolution of 14 bits or 12 bits. The ADC resolution can be traded off with conversion rate, and can operate at maximum speeds of 65 MSPS and 80 MSPS at 14-bit and 12-bit resolution, respectively. The ADC is designed to scale its power with sampling rate. The output interface of the ADC comes out through a low-voltage differential signaling (LVDS) that can easily interface with low-cost field-programmable gate arrays (FPGAs).

The AFE58JD28 additionally includes a digital demodulator and JESD204B data packing blocks. The digital in-phase and quadrature (I/Q) demodulator with programmable decimation filters accelerates computationally-intensive algorithms at low power. The device also supports an optional JESD204B interface that runs up to 5 Gbps and further reduces the circuit-board routing challenges in high-channel count systems.

The device also allows various power and noise combinations to be selected for optimizing system performance. Therefore, these devices are suitable ultrasound AFE solutions for systems with strict battery-life requirements.

The device is available in a 15-mm × 15-mm NFBGA-289 package and is pin-compatible with the [AFE5818](#) and [AFE5816](#) family.

5 Device and Documentation Support

5.1 Documentation Support

5.1.1 Related Documentation

For related documentation see the following:

- [AFE5818 16-Channel, Ultrasound, Analog Front-End with 140-mW/Channel Power, 0.75-nV/ \$\sqrt{\text{Hz}}\$ Noise, 14-Bit, 65-MSPS or 12-Bit, 80-MSPS ADC, and Passive CW Mixer](#)
- [AFE5816 16-Channel Ultrasound AFE with 90-mW/Channel Power, 1-nV/ \$\sqrt{\text{Hz}}\$ Noise, 14-Bit, 65-MSPS or 12-Bit, 80-MSPS ADC and Passive CW Mixer](#)
- [AFE58JD18 16-Channel, Ultrasound AFE with 14-Bit, 65-MSPS or 12-Bit, 80-MSPS ADC, Passive CW Mixer, I/Q Demodulator, and LVDS, JESD204B Outputs](#)
- [TLV5626 2.7-V to 5.5-V Low-Power Dual 8-Bit Digital-to-Analog Converter With Internal Reference and Power Down](#)
- [DAC7821 12-Bit, Parallel Input, Multiplying Digital-to-Analog Converter](#)
- [THS413x High-Speed, Low-Noise, Fully-Differential I/O Amplifiers](#)
- [OPA1632 High-Performance, Fully-Differential Audio Operational Amplifier](#)
- [Wideband Differential Transimpedance DAC Output](#)
- [LMK0482x Ultra Low-Noise JESD204B Compliant Clock Jitter Cleaner with Dual Loop PLLs](#)
- [CDCM7005 3.3-V High Performance Clock Synchronizer and Jitter Cleaner](#)
- [CDCE72010 Ten Output High Performance Clock Synchronizer, Jitter Cleaner, and Clock Distributor](#)
- [OPA2x11 1.1-nV/ \$\sqrt{\text{Hz}}\$ Noise, Low Power, Precision Operational Amplifier](#)
- [ADS8413 16-Bit, 2-MSPS, LVDS Serial Interface, SAR Analog-to-Digital Converter](#)
- [ADS8472 16-Bit, 1-MSPS, Pseudo-Bipolar, Fully Differential Input, Micropower Sampling Analog-to-Digital Converter With Parallel Interface, Reference](#)
- [Clocking High-Speed Data Converters Technical Brief](#)
- [ISO724x High-Speed, Quad-Channel Digital Isolators](#)
- [SN74AUP1T04 Low Power, 1.8/2.5/3.3-V Input, 3.3-V CMOS Output, Single Inverter Gate](#)
- [MicroStar BGA Packaging Reference Guide](#)

5.2 Trademarks

All trademarks are the property of their respective owners.

5.3 Electrostatic Discharge Caution



These devices have limited built-in ESD protection. The leads should be shorted together or the device placed in conductive foam during storage or handling to prevent electrostatic damage to the MOS gates.

5.4 Glossary

[SLYZ022](#) — *TI Glossary*.

This glossary lists and explains terms, acronyms, and definitions.

6 Mechanical, Packaging, and Orderable Information

The following pages include mechanical, packaging, and orderable information. This information is the most current data available for the designated devices. This data is subject to change without notice and revision of this document. For browser-based versions of this data sheet, refer to the left-hand navigation.

MECHANICAL DATA

ZAV (S-PBGA-N289)

PLASTIC BALL GRID ARRAY

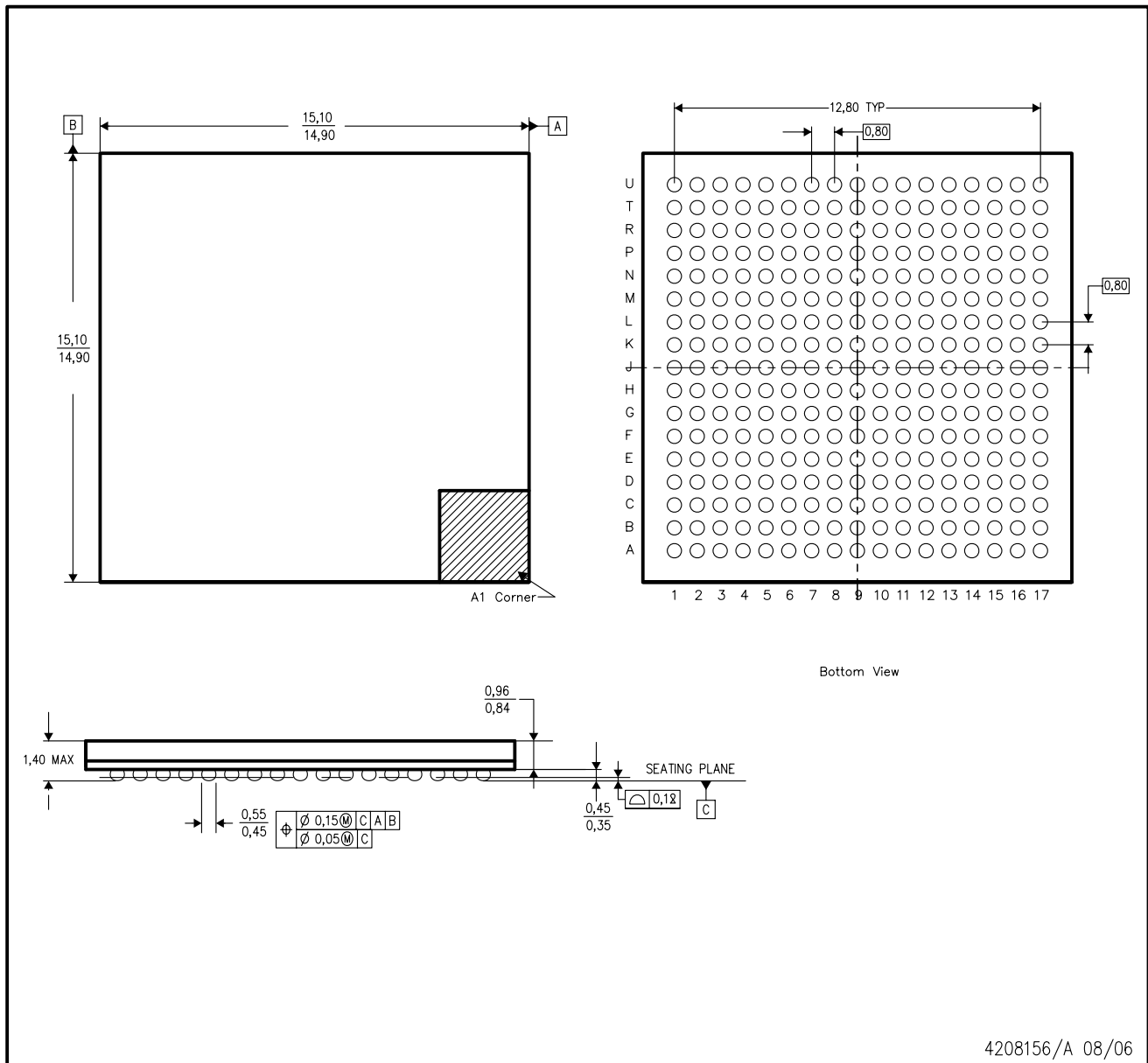

- NOTES:
- A. All linear dimensions are in millimeters.
 - B. This drawing is subject to change without notice.
 - C. This is a lead-free solder ball design.

PACKAGING INFORMATION

| Orderable Device | Status (1) | Package Type | Package Drawing | Pins | Package Qty | Eco Plan (2) | Lead/Ball Finish (6) | MSL Peak Temp (3) | Op Temp (°C) | Device Marking (4/5) | Samples |
|------------------|---------------|--------------|--------------------|------|----------------|----------------------------|-------------------------|----------------------|--------------|-------------------------|----------------|
| AFE58JD28ZAV | ACTIVE | NFBGA | ZAV | 289 | 126 | Green (RoHS & no Sb/Br) | SNAGCU | Level-3-260C-168 HR | -40 to 85 | AFE58JD28 AFE5828 | Samples |

(1) The marketing status values are defined as follows:

ACTIVE: Product device recommended for new designs.

LIFEBUY: TI has announced that the device will be discontinued, and a lifetime-buy period is in effect.

NRND: Not recommended for new designs. Device is in production to support existing customers, but TI does not recommend using this part in a new design.

PREVIEW: Device has been announced but is not in production. Samples may or may not be available.

OBSOLETE: TI has discontinued the production of the device.

(2) **RoHS:** TI defines "RoHS" to mean semiconductor products that are compliant with the current EU RoHS requirements for all 10 RoHS substances, including the requirement that RoHS substance do not exceed 0.1% by weight in homogeneous materials. Where designed to be soldered at high temperatures, "RoHS" products are suitable for use in specified lead-free processes. TI may reference these types of products as "Pb-Free".

RoHS Exempt: TI defines "RoHS Exempt" to mean products that contain lead but are compliant with EU RoHS pursuant to a specific EU RoHS exemption.

Green: TI defines "Green" to mean the content of Chlorine (Cl) and Bromine (Br) based flame retardants meet JS709B low halogen requirements of <=1000ppm threshold. Antimony trioxide based flame retardants must also meet the <=1000ppm threshold requirement.

(3) MSL, Peak Temp. - The Moisture Sensitivity Level rating according to the JEDEC industry standard classifications, and peak solder temperature.

(4) There may be additional marking, which relates to the logo, the lot trace code information, or the environmental category on the device.

(5) Multiple Device Markings will be inside parentheses. Only one Device Marking contained in parentheses and separated by a "~" will appear on a device. If a line is indented then it is a continuation of the previous line and the two combined represent the entire Device Marking for that device.

(6) Lead/Ball Finish - Orderable Devices may have multiple material finish options. Finish options are separated by a vertical ruled line. Lead/Ball Finish values may wrap to two lines if the finish value exceeds the maximum column width.

Important Information and Disclaimer:The information provided on this page represents TI's knowledge and belief as of the date that it is provided. TI bases its knowledge and belief on information provided by third parties, and makes no representation or warranty as to the accuracy of such information. Efforts are underway to better integrate information from third parties. TI has taken and continues to take reasonable steps to provide representative and accurate information but may not have conducted destructive testing or chemical analysis on incoming materials and chemicals. TI and TI suppliers consider certain information to be proprietary, and thus CAS numbers and other limited information may not be available for release.

In no event shall TI's liability arising out of such information exceed the total purchase price of the TI part(s) at issue in this document sold by TI to Customer on an annual basis.

IMPORTANT NOTICE

Texas Instruments Incorporated (TI) reserves the right to make corrections, enhancements, improvements and other changes to its semiconductor products and services per JESD46, latest issue, and to discontinue any product or service per JESD48, latest issue. Buyers should obtain the latest relevant information before placing orders and should verify that such information is current and complete.

TI's published terms of sale for semiconductor products (<http://www.ti.com/sc/docs/stdterms.htm>) apply to the sale of packaged integrated circuit products that TI has qualified and released to market. Additional terms may apply to the use or sale of other types of TI products and services.

Reproduction of significant portions of TI information in TI data sheets is permissible only if reproduction is without alteration and is accompanied by all associated warranties, conditions, limitations, and notices. TI is not responsible or liable for such reproduced documentation. Information of third parties may be subject to additional restrictions. Resale of TI products or services with statements different from or beyond the parameters stated by TI for that product or service voids all express and any implied warranties for the associated TI product or service and is an unfair and deceptive business practice. TI is not responsible or liable for any such statements.

Buyers and others who are developing systems that incorporate TI products (collectively, "Designers") understand and agree that Designers remain responsible for using their independent analysis, evaluation and judgment in designing their applications and that Designers have full and exclusive responsibility to assure the safety of Designers' applications and compliance of their applications (and of all TI products used in or for Designers' applications) with all applicable regulations, laws and other applicable requirements. Designer represents that, with respect to their applications, Designer has all the necessary expertise to create and implement safeguards that (1) anticipate dangerous consequences of failures, (2) monitor failures and their consequences, and (3) lessen the likelihood of failures that might cause harm and take appropriate actions. Designer agrees that prior to using or distributing any applications that include TI products, Designer will thoroughly test such applications and the functionality of such TI products as used in such applications.

TI's provision of technical, application or other design advice, quality characterization, reliability data or other services or information, including, but not limited to, reference designs and materials relating to evaluation modules, (collectively, "TI Resources") are intended to assist designers who are developing applications that incorporate TI products; by downloading, accessing or using TI Resources in any way, Designer (individually or, if Designer is acting on behalf of a company, Designer's company) agrees to use any particular TI Resource solely for this purpose and subject to the terms of this Notice.

TI's provision of TI Resources does not expand or otherwise alter TI's applicable published warranties or warranty disclaimers for TI products, and no additional obligations or liabilities arise from TI providing such TI Resources. TI reserves the right to make corrections, enhancements, improvements and other changes to its TI Resources. TI has not conducted any testing other than that specifically described in the published documentation for a particular TI Resource.

Designer is authorized to use, copy and modify any individual TI Resource only in connection with the development of applications that include the TI product(s) identified in such TI Resource. NO OTHER LICENSE, EXPRESS OR IMPLIED, BY ESTOPPEL OR OTHERWISE TO ANY OTHER TI INTELLECTUAL PROPERTY RIGHT, AND NO LICENSE TO ANY TECHNOLOGY OR INTELLECTUAL PROPERTY RIGHT OF TI OR ANY THIRD PARTY IS GRANTED HEREIN, including but not limited to any patent right, copyright, mask work right, or other intellectual property right relating to any combination, machine, or process in which TI products or services are used. Information regarding or referencing third-party products or services does not constitute a license to use such products or services, or a warranty or endorsement thereof. Use of TI Resources may require a license from a third party under the patents or other intellectual property of the third party, or a license from TI under the patents or other intellectual property of TI.

TI RESOURCES ARE PROVIDED "AS IS" AND WITH ALL FAULTS. TI DISCLAIMS ALL OTHER WARRANTIES OR REPRESENTATIONS, EXPRESS OR IMPLIED, REGARDING RESOURCES OR USE THEREOF, INCLUDING BUT NOT LIMITED TO ACCURACY OR COMPLETENESS, TITLE, ANY EPIDEMIC FAILURE WARRANTY AND ANY IMPLIED WARRANTIES OF MERCHANTABILITY, FITNESS FOR A PARTICULAR PURPOSE, AND NON-INFRINGEMENT OF ANY THIRD PARTY INTELLECTUAL PROPERTY RIGHTS. TI SHALL NOT BE LIABLE FOR AND SHALL NOT DEFEND OR INDEMNIFY DESIGNER AGAINST ANY CLAIM, INCLUDING BUT NOT LIMITED TO ANY INFRINGEMENT CLAIM THAT RELATES TO OR IS BASED ON ANY COMBINATION OF PRODUCTS EVEN IF DESCRIBED IN TI RESOURCES OR OTHERWISE. IN NO EVENT SHALL TI BE LIABLE FOR ANY ACTUAL, DIRECT, SPECIAL, COLLATERAL, INDIRECT, PUNITIVE, INCIDENTAL, CONSEQUENTIAL OR EXEMPLARY DAMAGES IN CONNECTION WITH OR ARISING OUT OF TI RESOURCES OR USE THEREOF, AND REGARDLESS OF WHETHER TI HAS BEEN ADVISED OF THE POSSIBILITY OF SUCH DAMAGES.

Unless TI has explicitly designated an individual product as meeting the requirements of a particular industry standard (e.g., ISO/TS 16949 and ISO 26262), TI is not responsible for any failure to meet such industry standard requirements.

Where TI specifically promotes products as facilitating functional safety or as compliant with industry functional safety standards, such products are intended to help enable customers to design and create their own applications that meet applicable functional safety standards and requirements. Using products in an application does not by itself establish any safety features in the application. Designers must ensure compliance with safety-related requirements and standards applicable to their applications. Designer may not use any TI products in life-critical medical equipment unless authorized officers of the parties have executed a special contract specifically governing such use. Life-critical medical equipment is medical equipment where failure of such equipment would cause serious bodily injury or death (e.g., life support, pacemakers, defibrillators, heart pumps, neurostimulators, and implantables). Such equipment includes, without limitation, all medical devices identified by the U.S. Food and Drug Administration as Class III devices and equivalent classifications outside the U.S.

TI may expressly designate certain products as completing a particular qualification (e.g., Q100, Military Grade, or Enhanced Product). Designers agree that it has the necessary expertise to select the product with the appropriate qualification designation for their applications and that proper product selection is at Designers' own risk. Designers are solely responsible for compliance with all legal and regulatory requirements in connection with such selection.

Designer will fully indemnify TI and its representatives against any damages, costs, losses, and/or liabilities arising out of Designer's non-compliance with the terms and provisions of this Notice.