

■ Features

- Monolithic structure for highly reliable surface mount applications.
- Excellent solderability and high heat resistance for either flow or reflow soldering.
- No cross coupling between inductors due to magnetic shield. Ideal for high density installation.
- Operating temperature: -40°C ~ +85°C.

■ Applications

- Prevention of electromagnetic interference to signals on the secondary side of electric equipment

■ Product Identification

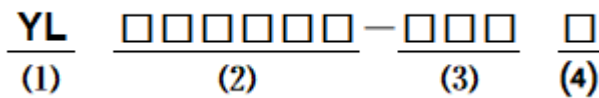

(1) : Type

(2) : Dimensions

(3) : Inductance value

(4) : Inductance Tolerance; N=±30%,M=±20%, K=±10%

■ Shapes and Dimensions (Unit: mm)

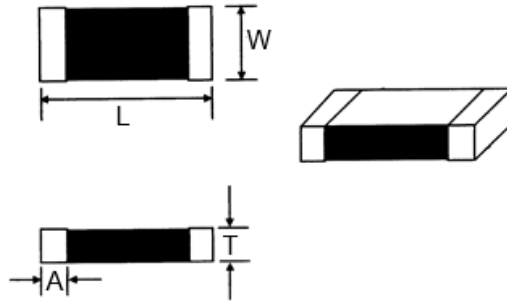

TYPE	L	W	T	A
YL201209 [0805]	2.00±0.20	1.25±0.20	0.90±0.05	0.50±0.30
YL201212 [0805]	2.00±0.20	1.25±0.20	1.25±0.20	0.50±0.30

■ YL2012 Series

Part Number	Inductance (μ H)	Q Min.	Test Freq. (MHz)	Min.SRF (MHz)	DCR MAX. (Ω)	Max.Rated Current (mA)
YL201209-47N□	0.047	15	50	320	0.20	300
YL201209-68N□	0.068	15	50	280	0.20	300
YL201209-82N□	0.082	15	50	255	0.20	300
YL201209-R10□	0.100	20	25	235	0.30	250
YL201209-R12□	0.120	20	25	220	0.30	250
YL201209-R15□	0.150	20	25	200	0.40	250
YL201209-R18□	0.180	20	25	185	0.40	250
YL201209-R22□	0.220	20	25	170	0.50	250
YL201209-R27□	0.270	20	25	150	0.50	250
YL201209-R33□	0.330	20	25	145	0.55	250
YL201209-R39□	0.390	25	25	135	0.65	200
YL201209-R47□	0.470	25	25	125	0.65	200
YL201209-R56□	0.560	25	25	115	0.75	150

YL2012 Series

Part Number	Inductance (μ H)	Q Min.	Test Freq. (MHz)	Min.SRF (MHz)	DCR MAX. (Ω)	Max.Rated Current (mA)
YL201209-R68□	0.680	25	25	105	0.80	150
YL201209-R82□	0.820	25	25	100	1.00	150
YL201209-1R0□	1.0	45	10	75	0.40	50
YL201209-1R1□	1.1	45	10	65	0.50	50
YL201209-1R2□	1.2	45	10	65	0.50	50
YL201209-1R5□	1.5	45	10	60	0.50	50
YL201209-1R8□	1.8	45	10	55	0.60	50
YL201209-2R2□	2.2	45	10	50	0.65	30
YL201209-2R4□	2.4	45	10	47	0.70	30
YL201209-2R7□	2.7	45	10	45	0.75	30
YL201209-3R3□	3.3	45	10	41	0.80	30
YL201209-3R9□	3.9	45	10	38	0.90	30
YL201209-4R7□	4.7	45	10	35	1.00	30
YL201209-5R6□	5.6	50	4	32	0.90	15
YL201209-6R8□	6.8	50	4	29	1.00	15
YL201209-8R2□	8.2	50	4	26	1.10	15
YL201209-100□	10	50	2	24	1.15	15
YL201209-120□	12	50	2	22	1.25	15
YL201209-150□	15	30	1	19	0.80	5
YL201209-180□	18	30	1	18	0.90	5
YL201209-220□	22	30	1	16	1.10	5
YL201212-270□	27	30	1	14	1.15	5
YL201212-330□	33	30	1	13	1.25	5
YL201212-390□	39	35	1	8	2.90	4
YL201212-470□	47	35	1	8	3.00	4

Reliability test

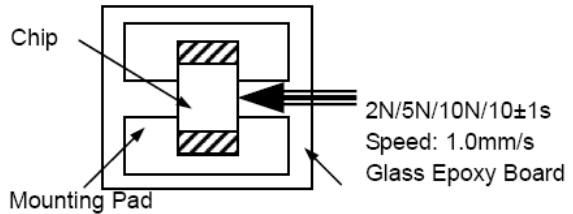
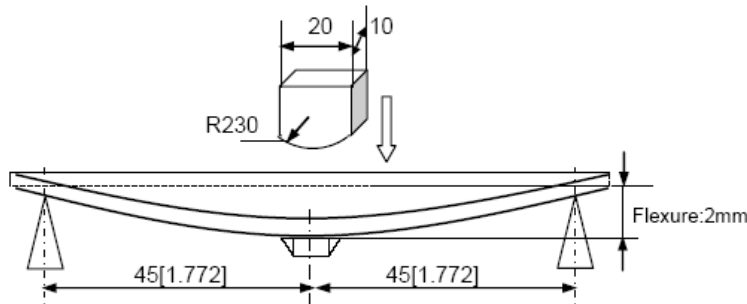
Items	Requirements	Test Methods and Remarks
Operating Temperature Range		-40℃ to + 85℃
Storage Temperature Range		-40℃ to + 85℃
Terminal Strength	No removal or split of the termination or other defects shall occur	<p>① Solder the inductor to the testing jig(glass epoxy board shown as the following figure)using eutectic solder.Then apply a force in the direction of the arrow.</p> <p>② 2N force for 0603 series.</p> <p>③ 5N force for 1005 and 1608 series.</p> <p>④ 10N force for 2012 3216 3225 4532 series.</p> <p>⑤ Keep time :10±1s.</p> <p>⑥ Speed:1.0mm/s.</p> 
Resistance to Flexure	No visible mechanical damage.	<p>① Solder the inductor to the test jig(glass epoxy board) using a eutectic solder.Then apply a force in the direction of the arrow shown as the following figure.</p> <p>② Flexure:2mm.</p> <p>③ Pressurizing Speed:0.5mm/sec.</p> <p>④ Keep time:≥30 sec.</p> 

■ Reliability test

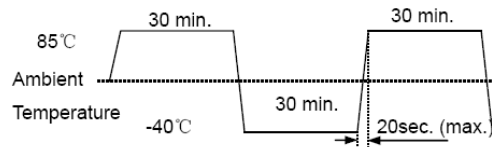
Items	Requirements	Test Methods and Remarks
Vibration	<ul style="list-style-type: none"> ① No visible mechanical damage. ② Inductance change: Within $\pm 10\%$. ③ Q factor change: Within $\pm 30\%$. 	<ul style="list-style-type: none"> ① Solder the inductor to the testing jig using eutectic solder. ② The inductor shall be subjected to a simple harmonic motion having total amplitude of 1.5 mm, the frequency being varied uniformly between the approximate limits of 10 and 55 Hz. ③ The frequency range from 10 to 55 Hz and return to 10 Hz shall be traversed in approximately 1 minute. This motion shall be applied for a period of 2 hours in each 3 mutually perpendicular directions (total of 6 hours).
Dropping	<ul style="list-style-type: none"> ① No visible mechanical damage. ② Inductance change: Within $\pm 20\%$. ③ Q factor change: Within $\pm 30\%$. 	Drop chip inductor 10 times on a concrete floor from a height of 100 cm.
Temperature	Inductance change should be within $\pm 20\%$ of initial value measuring at 20°C.	Temperature range: -40°C to +85°C Reference temperature: +20°C
Solderability	<ul style="list-style-type: none"> ① No visible mechanical damage. ② Wetting shall exceed 95% coverage. 	<ul style="list-style-type: none"> ① Solder temperature: 240\pm2°C. ② Duration: 3 sec. ③ Solder: Sn/3.0Ag/0.5Cu. ④ Flux: 25% Resin and 75% ethanol in weight.
Resistance to Soldering Heat	<ul style="list-style-type: none"> ① No visible mechanical damage. ② Wetting shall exceed 95% coverage. ③ Inductance change: Within $\pm 10\%$. ④ Q factor change: Within $\pm 30\%$. 	<ul style="list-style-type: none"> ① Solder temperature: 260\pm3°C. ② Duration: 5 sec. ③ Solder: Sn/3.0Ag/0.5Cu. ④ Flux: 25% Resin and 75% ethanol in weight. ⑤ The chip shall be stabilized at normal condition for 1~2 hours before measuring.
Thermal Shock	<ul style="list-style-type: none"> ① No visible mechanical damage. ② Inductance change: Within $\pm 10\%$. ③ Q factor change: Within $\pm 30\%$. 	<ul style="list-style-type: none"> ① Temperature and time: -40°C for 30\pm3 min \rightarrow 85°C for 30\pm3min. ② Transforming interval: Max.20 sec. ③ Tested cycle: 100 cycles. ④ The chip shall be stabilized at normal condition for 1~2 hours before measuring. 

■ Reliability test

Items	Requirements	Test Methods and Remarks
Resistance to Low Temperature	① No visible mechanical damage. ② Inductance change: Within $\pm 10\%$. ③ Q factor change: Within $\pm 30\%$.	① Temperature: $-40\pm 2^{\circ}\text{C}$. ② Duration: 1000+24 hours. ③ The chip shall be stabilized at normal condition for 1~2 hours before measuring.
Resistance to High Temperature	① No visible mechanical damage. ② Inductance change: Within $\pm 10\%$. ③ Q factor change: Within $\pm 30\%$.	① Temperature: $85\pm 2^{\circ}\text{C}$. ② Duration: 1000+24 hours. ③ The chip shall be stabilized at normal condition for 1~2 hours before measuring.
Damp Heat (Steady States)	① No visible mechanical damage. ② Inductance change: Within $\pm 10\%$. ③ Q factor change: Within $\pm 30\%$.	① Temperature: $60\pm 2^{\circ}\text{C}$. ② Humidity: 90% to 95% RH. ③ Duration: 1000+24 hours. ④ The chip shall be stabilized at normal condition for 1~2 hours before measuring.
Loading Under Damp Heat	① No visible mechanical damage. ② Inductance change: Within $\pm 10\%$ for inductance $\leq 12 \mu\text{H}$, Within $\pm 15\%$ for inductance $\geq 15 \mu\text{H}$. ③ Q factor change: Within $\pm 30\%$.	① Temperature: $60\pm 2^{\circ}\text{C}$. ② Humidity: 90% to 95% RH. ③ Duration: 1000+24 hours. ④ Applied current: Rated current. ⑤ The chip shall be stabilized at normal condition for 1~2 hours before measuring.
Loading at High Temperature (Life Test)	① No visible mechanical damage. ② Inductance change: Within $\pm 10\%$ for inductance $\leq 12 \mu\text{H}$, Within $\pm 15\%$ for inductance $\geq 15 \mu\text{H}$. ③ Q factor change: Within $\pm 30\%$.	① Temperature: $85\pm 2^{\circ}\text{C}$. ② Duration: 1000+24 hours. ③ Applied current: Rated current. ④ The chip shall be stabilized at normal condition for 1~2 hours before measuring.

■ Taping Dimensions(Unit:mm)

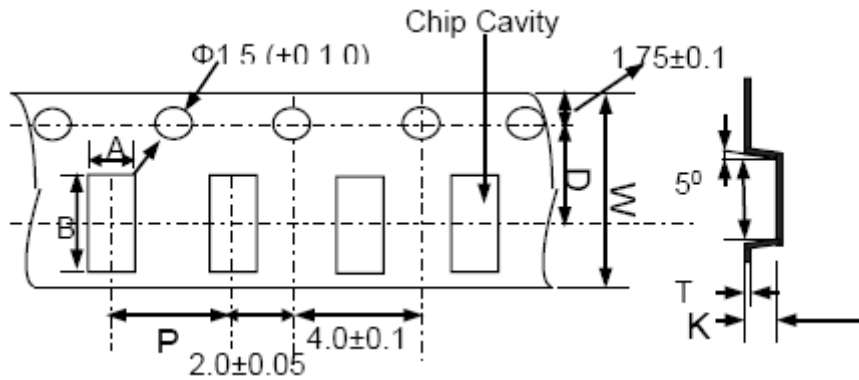

TYPE	Chip Thickness	W	A	B	D	P	K Max	T Max	MPQ
YL201209	0.90	8.0	1.50	2.30	3.50	4.0	1.10	0.30	4000
YL201212	1.25	8.0	1.55	2.25	3.50	4.0	1.45	0.30	3000

■ Reel Dimensions(Unit:mm)

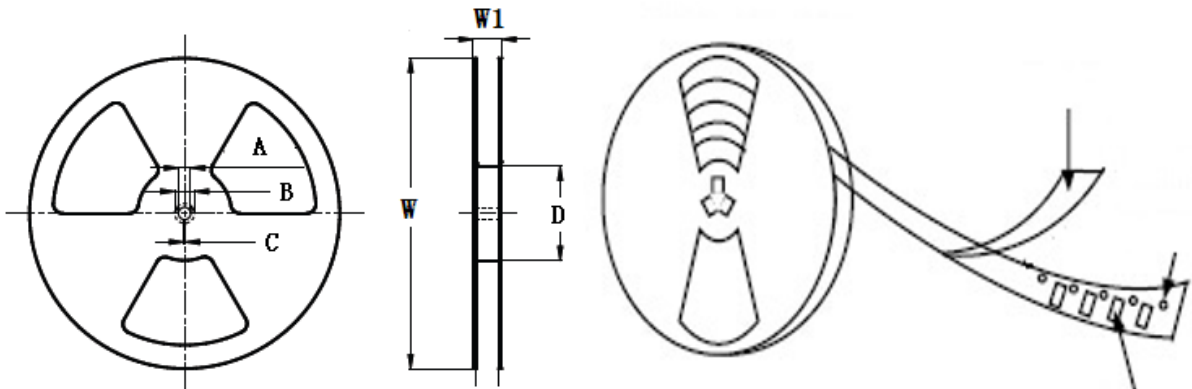

TYPE	W	W1	A	B	C	D
YL Series	178±2.0	8.40±1.50	4.3±0.20	5.0±0.10	3.0±0.10	58±2.0
	178±2.0	12.40±1.50	4.3±0.20	5.0±0.10	3.0±0.10	58±2.0

Leader and Blank portion

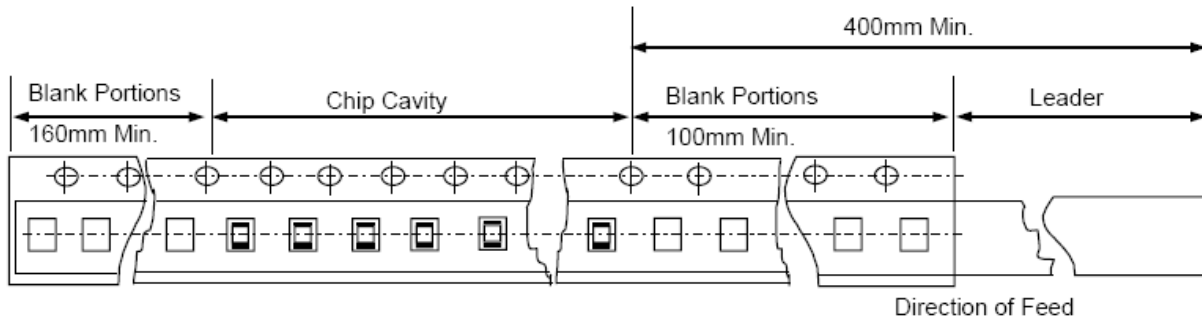

1. Missing chips number within 0.1% of the number per reel or 1pcs, whichever is greater, and are not continuous.
2. The top tape and bottom tape shall not protrude beyond the edges of the tape and shall not cover sprocket hole.
3. Cumulative tolerance of sprocket holes, 10 pitches: $\pm 0.3\text{mm}$.
4. Peeling off force: 10gf to 100gf in the direction show below for 8mm carrier tapes and 10gf to 130gf for 12mm to 56mm wide carrier tapes.

