

NOT RECOMMENDED FOR NEW DESIGN
USE [AP3125A/V/L/R](#)

AP3105/V/L/R

COST EFFECTIVE GREEN PWM CONTROLLER

Description

The AP3105/V/L/R is a low startup current, current mode PWM controller with green-mode power-saving operation. The PWM switching frequency at normal operation is set with 65kHz typically and the dithering of frequency will also improve the EMI feature. When the load decreases, the frequency will reduce and when at a very low load, the IC will enter the 'burst mode' to minimize switching loss.

About 20kHz frequency switching is to avoid the audible noise as well as reducing the standby loss. The skip mode point can be adjusted through the external resistor connected to the current sense resistor.

The AP3105/V/L/R features a lot of functions such as the Leading-Edge Blanking (LEB) of the current sensing, internal slope compensation and several protection functions including cycle-by-cycle current limit (OCP), VCC Over Voltage Protection (VOVP), OTP and OLP protection. The versatile latch function can be set by the customer through few components.

This IC is available in SOT-23-6 package.

Features

- Very Low Start-up Current
- Current Mode Control
- Non-audible-noise Green-mode Control
- Skip Mode Adjustable
- Internal Slope Compensation
- Soft Start During Startup Process
- Frequency Fold Back for High Average Efficiency
- Secondary Short Winding Protection with FOC
- Soft Switching for Reducing EMI
- VCC Maintain Mode
- Latch Function for OTP/OVP
- Useful Pin Fault Protection:
 - SENSE Pin Floating
 - CTRL Pin Short to Ground
 - FB/Opto-coupler Open/Short
- Comprehensive System Protection Feature:
 - VCC Over Voltage Protection (VOVP)
 - Over Load Protection (OLP)
- Mini Size with Packages
- Pin to Pin Compatible with AP3103

Pin Assignments

(Top View)

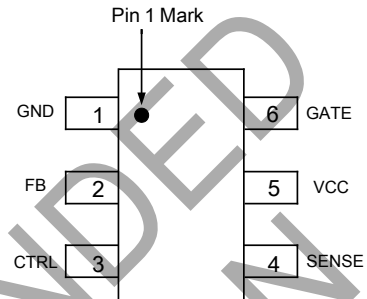

SOT-23-6 (K Package)

Applications

- Switching AC-DC Adapter/Charger
- ATX/BTX Auxiliary Power
- Set-top Box(STB) Power Supply
- Open Frame Switching Power Supply

Typical Applications Circuit

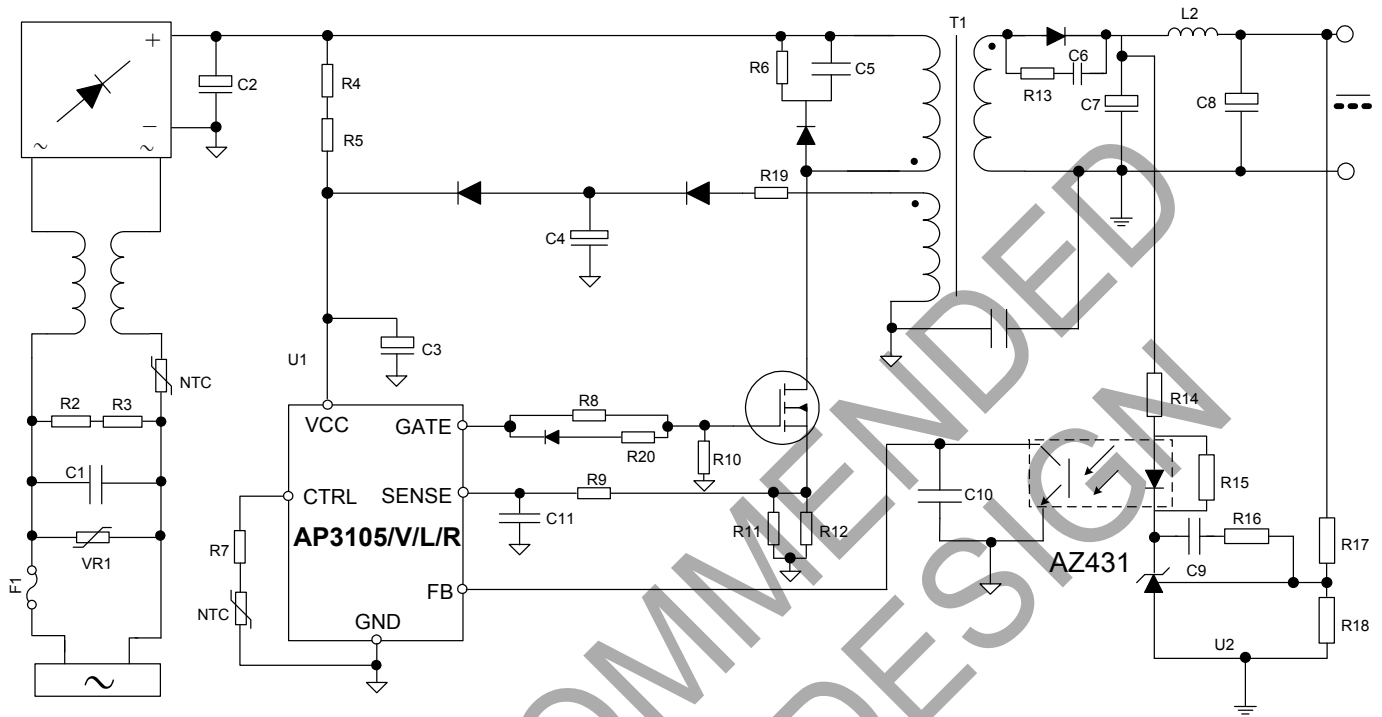

Pin Descriptions

Pin Number	Pin Name	Function
1	GND	Signal ground. Current return for driver and control circuits
2	FB	Feedback. Directly connected to the opto-coupler
3	CTRL	Latch trigger if this pin voltage drops below a threshold or over another threshold, leave CTRL pin open if this function is not needed. Connecting a NTC thermistor to GND can achieve OTP protection
4	SENSE	Current Sense
5	VCC	Supply voltage of driver and control circuits
6	GATE	Gate driver output

AP3105/V/L/R

Functional Block Diagram

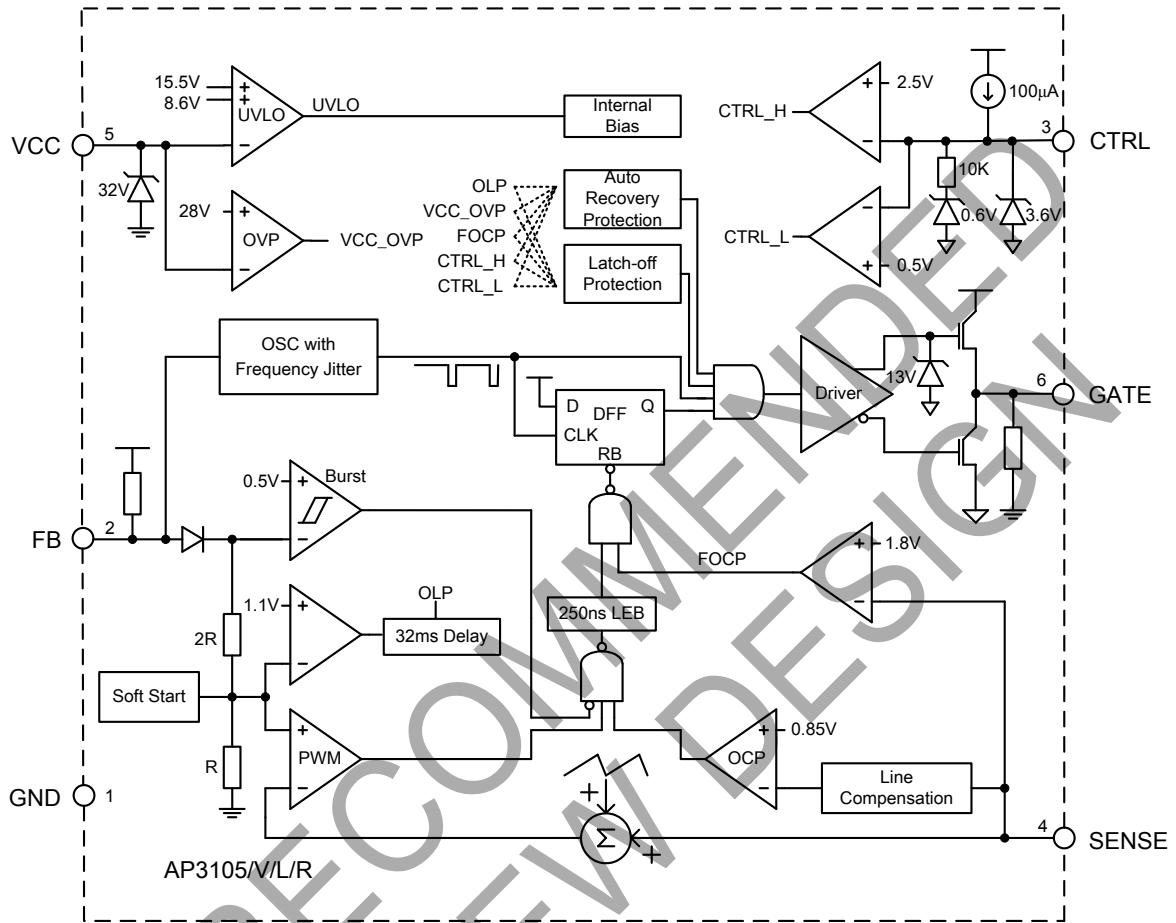

NOT RECOMMENDED FOR NEW DESIGN

Absolute Maximum Ratings (Note 1)

Symbol	Parameter	Rating	Unit
V_{CC}	Power Supply Voltage	30	V
I_O	Gate Output Current	350	mA
$V_{FB}, V_{SENSE}, V_{CTRL}$	Input Voltage to FB, SENSE, CTRL	-0.3 to 7	V
θ_{JA}	Thermal Resistance (Junction to Ambient)	250	°C/W
P_D	Power Dissipation at $T_A < 25^\circ\text{C}$	500	mW
T_J	Operating Junction Temperature	-40 to +150	°C
T_{STG}	Storage Temperature Range	+150	°C
–	ESD (Human Body Model)	3000	V
–	ESD (Machine Model)	300	V

Note 1. Stresses greater than those listed under "Absolute Maximum Ratings" may cause permanent damage to the device. These are stress ratings only, and functional operation of the device at these or any other conditions beyond those indicated under "Recommended Operating Conditions" is not implied. Exposure to "Absolute Maximum Ratings" for extended periods may affect device reliability.

Recommended Operating Conditions

Symbol	Parameter	Min	Max	Unit
V_{CC}	Supply Voltage	10	25	V

Electrical Characteristics (@ $T_A=+25^{\circ}\text{C}$, $V_{CC}=16\text{V}$, unless otherwise specified.)

Symbol	Parameter	Conditions	Min	Typ	Max	Unit
Supply Voltage (VCC Pin)						
I_{STARTUP}	Startup Current	–	2	5	25	μA
I_{CC}	Operating Supply Current	$V_{\text{FB}}=0\text{V}$, $C_L=1\text{nF}$	0.5	0.85	1.2	mA
		$V_{\text{FB}}=3\text{V}$, $C_L=0\text{nF}$	0.6	1.2	2.0	
–	UVLO (on)	–	14.5	15.5	16.5	V
–	VCC Maintain	–	9.7	10.2	10.7	V
–	UVLO (off)	–	7.6	8.6	9.6	V
–	VCC OVP	–	27	28.5	30	V
–	VCC Clamp	$I_{\text{CC}}=5\text{mA}$	31	34	–	V
PWM Section/Oscillator Section						
–	Maximum Duty Cycle	–	70	75	80	%
–	Oscillation Frequency	–	60	65	70	kHz
–	Green Mode Frequency	–	20	–	30	kHz
–	Frequency Temperature Stability	-20°C to $+125^{\circ}\text{C}$ (Note 2)	–	–	5	%
–	Frequency Voltage Stability	$V_{\text{CC}}=12\text{V}$ to 30V	–	–	3	%
–	Frequency Dithering	–	± 4	± 6	± 8	%
Current Sense Section (SENSE Pin)						
V_{CS}	Maximum SENSE Voltage	$V_{\text{FB}}=3.6\text{V}$	0.800	0.850	0.900	V
–	FOCP Voltage	–	1.65	1.8	1.95	V
–	LEB Time of SENSE	–	150	250	350	ns
–	Delay to Output (Note 2)	–	–	100	–	ns
–	Soft-start Time	–	3	5	8	ms
Feedback Input Section (FB Pin)						
–	The Ratio of Input Voltage to Current Sense Voltage	–	2.5	3	3.5	V/V
–	Input Impedance	–	7	10	13	k Ω
–	Source Current	$V_{\text{FB}}=0\text{V}$	-0.75	-0.5	-0.25	mA
–	Green Mode Threshold	–	–	2	–	V
–	Input Voltage for Zero Duty	–	1.3	1.55	1.8	V
Output Section (GATE Pin)						
–	Output Low Level	$I_O=20\text{mA}$, $V_{\text{CC}}=12\text{V}$	–	–	1	V
–	Output High Level	$I_O=20\text{mA}$, $V_{\text{CC}}=12\text{V}$	8	–	–	V
–	Output Clamping	–	11	13	15	V
–	Rising Time (Note 2)	$C_L=1\text{nF}$, $V_{\text{CC}}=13\text{V}$	–	150	250	ns
–	Falling Time (Note 2)	$C_L=1\text{nF}$, $V_{\text{CC}}=13\text{V}$	–	50	100	ns

Electrical Characteristics (Cont.) (@T_A=+25°C, V_{CC}=16V, unless otherwise specified.)

Protection Section (CTRL Pin)						
–	Source Current	–	90	100	110	μA
–	Internal Reference Voltage	–	–	1.5	–	V
–	Low Threshold Trigger for Latch	–	0.47	0.5	0.53	V
–	High Threshold Trigger for Latch	–	2.35	2.5	2.65	V
–	Pull-up Current (Note 3)	–	–	–	2	mA
Delay Time Section						
–	Delay of Short Circuit Protection	–	22	32	40	ms
–	Delay of Hiccup Protection	VCC OVP	–	25	–	μs

- Notes:
- 2 . Guaranteed by design.
 - 3 . The sourcing current of CTRL pin must be limited below 5mA. Otherwise it may cause permanent damage to the device.

NOT RECOMMENDED FOR NEW DESIGN

Performance Characteristics

Startup Voltage vs. Ambient Temperature

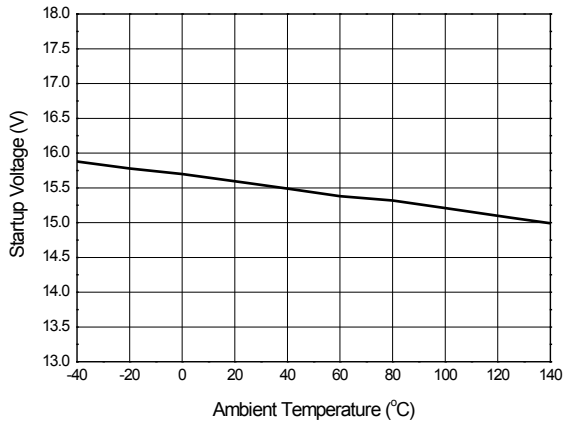

Shutdown Voltage vs. Ambient Temperature

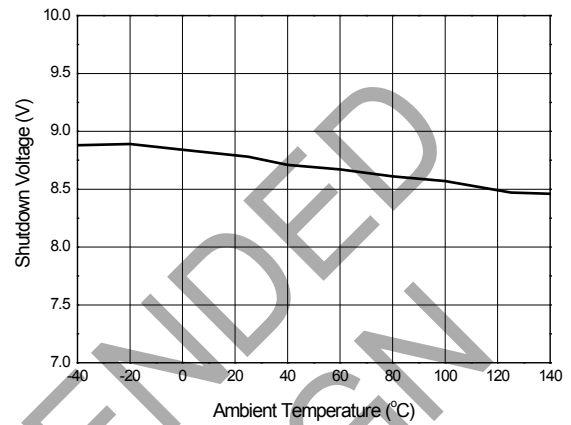

Startup Current vs. Ambient Temperature

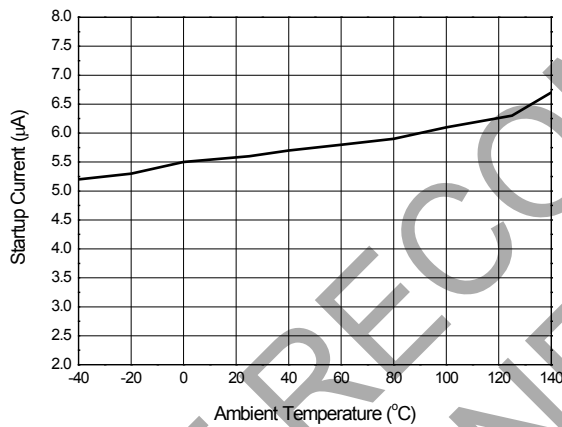

Operating Current vs. Ambient Temperature

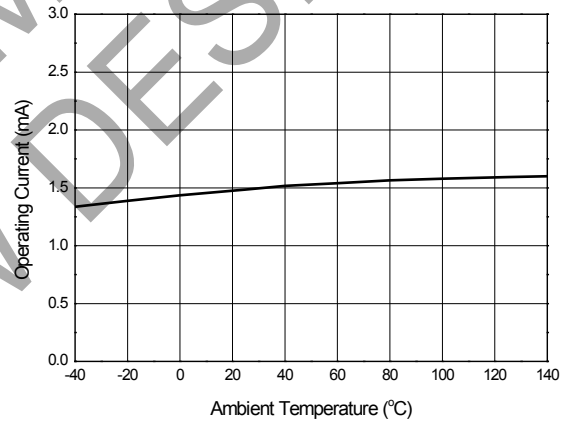

CTRL Utilization for Latch

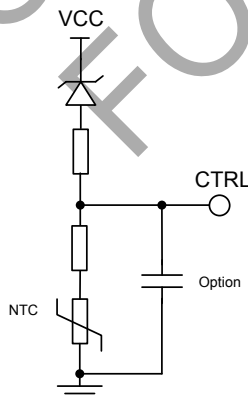

OVP and OTP

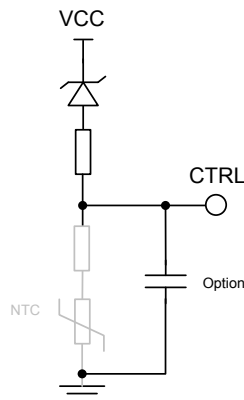

OVP

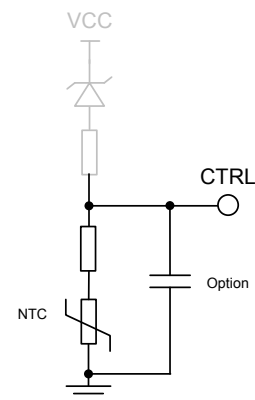

OTP

Operation Description

The AP3105/V/L/R is specifically designed for off-line AC-DC power supply used in LCD monitor, notebook adapter and battery charger applications. It offers a cost effective solution with a versatile protection function.

Start-up Current and UVLO

The start-up current of AP3105/V/L/R is optimized to realize ultra low current (5μA typical) so that VCC capacitor can be charged more quickly. The direct benefit of low start-up current is the availability of using large start-up resistor, which minimizes the resistor power loss for high voltage AC input.

An UVLO comparator is included in AP3105/V/L/R to detect the voltage on VCC pin. It ensures that AP3105/V/L/R can draw adequate energy from hold-up capacitor during power-on. The turn-on threshold is 15.5V and the turn-off threshold is 8.6V.

Current Sense Comparator and PWM Latch

The AP3105/V/L/R operates as a current mode controller, the output switch conduction is initiated by every oscillator cycle and is terminated when the peak inductor current reaches the threshold level established by the FB pin. The inductor current signal is converted to a voltage signal by inserting a reference sense resistor R_s . The inductor current under normal operating conditions is controlled by the voltage at FB pin. The relation between peak inductor current (I_{PK}) and V_{FB} is:

$$I_{PK} = (V_{FB} - 0.8) / 3R_s$$

Moreover, FOCV with 1.8V threshold is only about 100ns delay, which can avoid some catastrophic damages such as secondary rectifier short test. Few drive cycles can alleviate the destruction range and get better protection.

Leading-edge Blanking

A narrow spike on the leading edge of the current waveform can usually be observed when the power MOSFET is turned on. A 250ns leading-edge blank is built-in to prevent the false-triggering caused by the turn-on spike. During this period, the current limit comparator is disabled and the gate driver can not be switched off.

At the time of turning on the MOSFET, a negative undershoot (maybe larger than -0.3V) can occur on the SENSE pin. So it is strongly recommended to add a small RC filter or at least connect a resistor "R" on this pin to protect the IC (Shown as Figure 1).

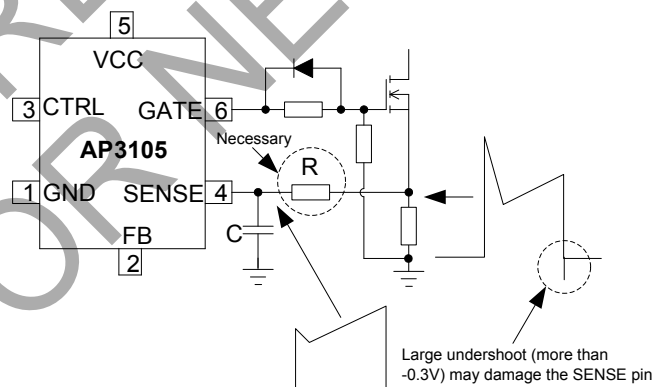

Figure 1

Built-in Slope Compensation

It is well known that a continuous current mode SMPS may become unstable when the duty cycle exceeds 50%. The built-in slope compensation can improve the stability, so there is no need for design engineer to spend much time on that.

Operation Description (Cont.)

FB Pin and Short Circuit Protection

This pin is normally connected to the opto-coupler and always paralleled with a capacitor for loop compensation. When the voltage at this pin is greater than 4.2V and lasts for about 32ms, the IC will enter the protection mode. For AP3105V/L/R, the system will enter hiccup mode to wait the V_{CC} decreasing to low UVLO level, then the IC will try to restart until the failure removed. And when this voltage is less than 1.55V, the IC will stop the drive pulse immediately. Therefore, this feature can be used for short circuit protection, which makes the system immune from damage. Normally, output short makes the V_{FB} value to the maximum because the opto-coupler is cut off.

V_{CC} Maintain Mode

During light load or step load, V_{FB} will drop and be lower than 1.55V, thus the PWM drive signal will be stopped, and there is no more new energy transferred due to no switching. Therefore, the IC supply voltage may reduce to the shutdown threshold voltage and system may enter the unexpected restart mode. To avoid this, the AP3105V/L/R hold a so-called V_{CC} maintain mode which can supply energy to V_{CC} .

When V_{CC} decreases to a setting threshold, the V_{CC} maintain comparator will output some drive signal to make the system switch and provide a proper energy to V_{CC} pin. The V_{CC} maintain function will cooperate the PWM and burst mode loop which can make the output voltage variation be within the regulation. This mode is very useful for reducing startup resistor loss and achieving a better standby performance with a low value V_{CC} capacitor. The V_{CC} is not easy to touch the shutdown threshold during the startup process and step load. This will also simplify the system design. The normal V_{CC} voltage is suggested to be designed a little higher than V_{CC} maintain threshold thus can achieve the best balance between the standby and step load performance.

System Protection and Pin Fault Protection

The AP3105V/L/R provides versatile system and pin fault protections. The OCP comparator realizes the cycle-by-cycle current limiting (OCP). In universal input line voltage, the IC realizes the constant over load protection (OLP). V_{CC} over voltage protection can be applied as the primary OVP or opto-coupler broken protection. The AP3105V/L/R also has pin fault connection protection including floating and short connection. The floating pin protection include the SENSE, FB, etc.. The short pin protection includes the CTRL pin short protection. When these pins are floated or CTRL pin is shorted to ground, PWM switching will be disabled, thus protecting the power system.

Latch Protection Function

For some applications, the system requires the latch protection function. The CTRL pin has two kinds of modes to trigger the latch protection: high level trigger and low level trigger. The low threshold is 0.5V and high threshold voltage is 2.5V. Some version will have only one mode. Once the latch protection is triggered, the IC will disable the output signal, and the bulk capacitor provides the energy to IC through the startup resistor to ensure the IC disable the output (latch mode). This mode will not be released until the AC input is shut off. So, the de-latch time is mainly depending on the HV startup bulk capacitor value. Therefore, if the system wants a short de-latch time, it is better for the startup resistor take power from the point before the rectifier bridge as illustrated in below figure.

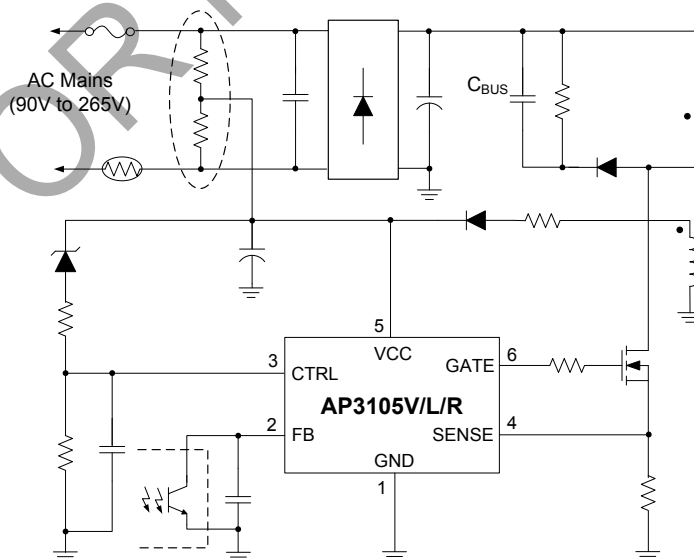

Ordering Information

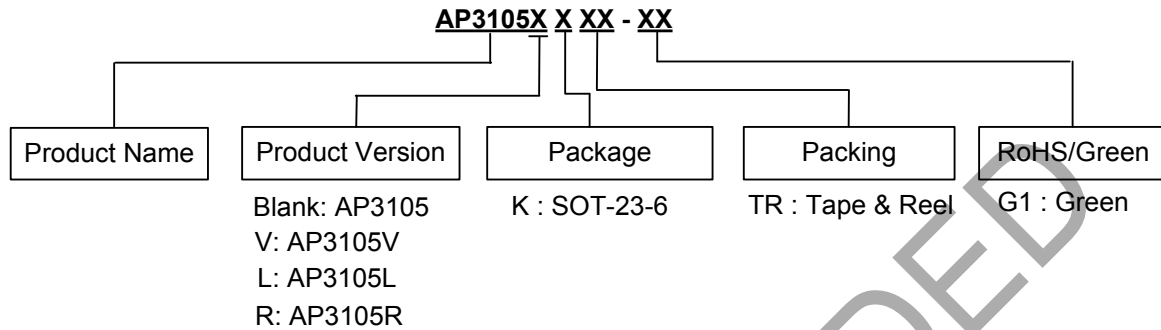

Diodes IC's Pb-free products with "G1" suffix in the part number, are RoHS compliant and green.

Package	Part Number	Marking ID	Packing Type
SOT-23-6	AP3105KTR-G1	GHN	Tape & Reel
	AP3105VKTR-G1	GHO	Tape & Reel
	AP3105LKTR-G1	GHP	Tape & Reel
	AP3105RKTR-G1	GHQ	Tape & Reel

*Product Version Classification (with Different Protection Functions)

Product Version	Frequency	VOVP	OLP&SOCP	CTRL (Low)	CTRL (High)
AP3105	65kHz	Auto-Recoverable	Auto-Recoverable	Latch	Auto-Recoverable
AP3105V	65kHz	Latch	Auto-Recoverable	Latch	Latch
AP3105L	65kHz	Latch	Latch	Latch	Latch
AP3105R	65kHz	Auto-Recoverable	Auto-Recoverable	Auto-Recoverable	Latch

AP3105/V/L/R

Package Outline Dimensions (All dimensions in mm(inch).)

(1) Package Type: SOT-23-6

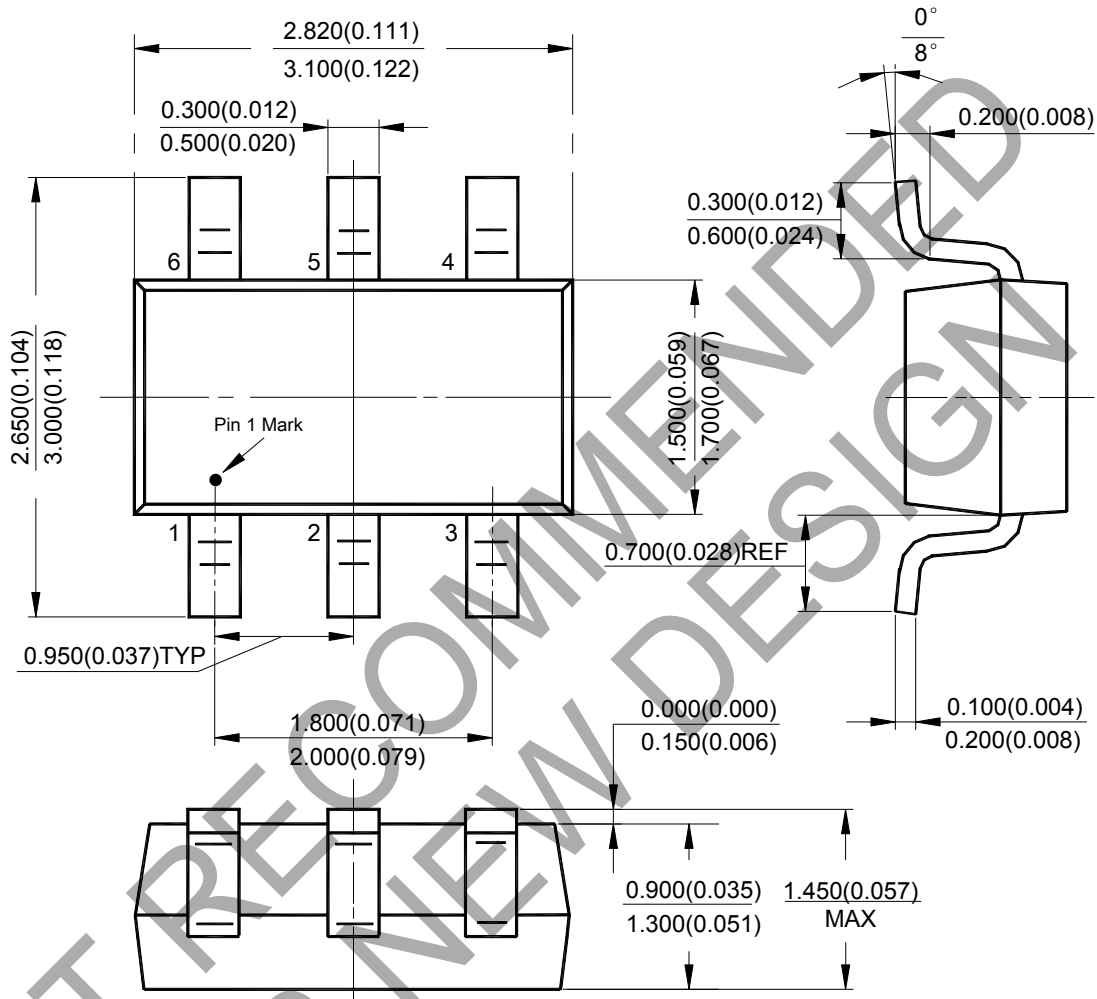

NOT FOR COMMERCIAL DESIGN

Suggested Pad Layout

(1) Package Type: SOT-23-6

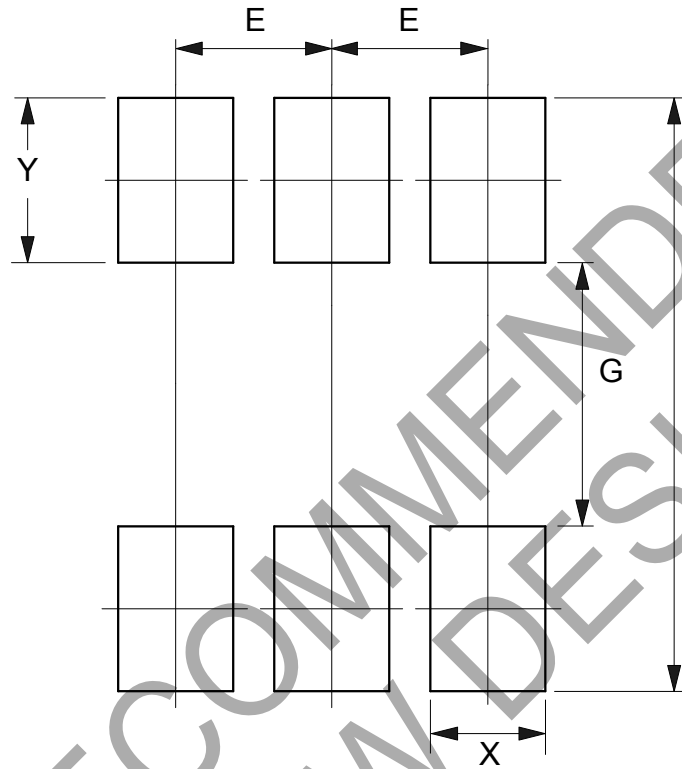

Dimensions	Z (mm)/(inch)	G (mm)/(inch)	X (mm)/(inch)	Y (mm)/(inch)	E (mm)/(inch)
Value	3.600/0.142	1.600/0.063	0.700/0.028	1.000/0.039	0.950/0.037

NOT RECOMMENDED FOR NEW DESIGN

IMPORTANT NOTICE

1. DIODES INCORPORATED AND ITS SUBSIDIARIES ("DIODES") MAKE NO WARRANTY OF ANY KIND, EXPRESS OR IMPLIED, WITH REGARDS TO ANY INFORMATION CONTAINED IN THIS DOCUMENT, INCLUDING, BUT NOT LIMITED TO, THE IMPLIED WARRANTIES OF MERCHANTABILITY, FITNESS FOR A PARTICULAR PURPOSE OR NON-INFRINGEMENT OF THIRD PARTY INTELLECTUAL PROPERTY RIGHTS (AND THEIR EQUIVALENTS UNDER THE LAWS OF ANY JURISDICTION).
2. The Information contained herein is for informational purpose only and is provided only to illustrate the operation of Diodes products described herein and application examples. Diodes does not assume any liability arising out of the application or use of this document or any product described herein. This document is intended for skilled and technically trained engineering customers and users who design with Diodes products. Diodes products may be used to facilitate safety-related applications; however, in all instances customers and users are responsible for (a) selecting the appropriate Diodes products for their applications, (b) evaluating the suitability of the Diodes products for their intended applications, (c) ensuring their applications, which incorporate Diodes products, comply the applicable legal and regulatory requirements as well as safety and functional-safety related standards, and (d) ensuring they design with appropriate safeguards (including testing, validation, quality control techniques, redundancy, malfunction prevention, and appropriate treatment for aging degradation) to minimize the risks associated with their applications.
3. Diodes assumes no liability for any application-related information, support, assistance or feedback that may be provided by Diodes from time to time. Any customer or user of this document or products described herein will assume all risks and liabilities associated with such use, and will hold Diodes and all companies whose products are represented herein or on Diodes' websites, harmless against all damages and liabilities.
4. Products described herein may be covered by one or more United States, international or foreign patents and pending patent applications. Product names and markings noted herein may also be covered by one or more United States, international or foreign trademarks and trademark applications. Diodes does not convey any license under any of its intellectual property rights or the rights of any third parties (including third parties whose products and services may be described in this document or on Diodes' website) under this document.
5. Diodes products are provided subject to Diodes' Standard Terms and Conditions of Sale (<https://www.diodes.com/about/company/terms-and-conditions/terms-and-conditions-of-sales/>) or other applicable terms. This document does not alter or expand the applicable warranties provided by Diodes. Diodes does not warrant or accept any liability whatsoever in respect of any products purchased through unauthorized sales channel.
6. Diodes products and technology may not be used for or incorporated into any products or systems whose manufacture, use or sale is prohibited under any applicable laws and regulations. Should customers or users use Diodes products in contravention of any applicable laws or regulations, or for any unintended or unauthorized application, customers and users will (a) be solely responsible for any damages, losses or penalties arising in connection therewith or as a result thereof, and (b) indemnify and hold Diodes and its representatives and agents harmless against any and all claims, damages, expenses, and attorney fees arising out of, directly or indirectly, any claim relating to any noncompliance with the applicable laws and regulations, as well as any unintended or unauthorized application.
7. While efforts have been made to ensure the information contained in this document is accurate, complete and current, it may contain technical inaccuracies, omissions and typographical errors. Diodes does not warrant that information contained in this document is error-free and Diodes is under no obligation to update or otherwise correct this information. Notwithstanding the foregoing, Diodes reserves the right to make modifications, enhancements, improvements, corrections or other changes without further notice to this document and any product described herein. This document is written in English but may be translated into multiple languages for reference. Only the English version of this document is the final and determinative format released by Diodes.
8. Any unauthorized copying, modification, distribution, transmission, display or other use of this document (or any portion hereof) is prohibited. Diodes assumes no responsibility for any losses incurred by the customers or users or any third parties arising from any such unauthorized use.

Copyright © 2020 Diodes Incorporated

www.diodes.com