

2SP0115T

Preliminary Description & Application Manual

Driver solution for 17mm dual IGBT modules with an electrical interface for 2-level, 3-level and multilevel converter topologies with paralleling capability

Abstract

The 2SP0115T is a dual-channel driver with an electrical interface. The driver is based on CONCEPT's SCALE™-2 chipset, a highly integrated technology for the reliable driving and safe operation of IGBTs.

Perfectly matched driver versions are available for all 17mm dual IGBT modules. The plug-and-play capability of the driver allows immediate operation after mounting. The user needs invest no effort in designing or adjusting it to a specific application.

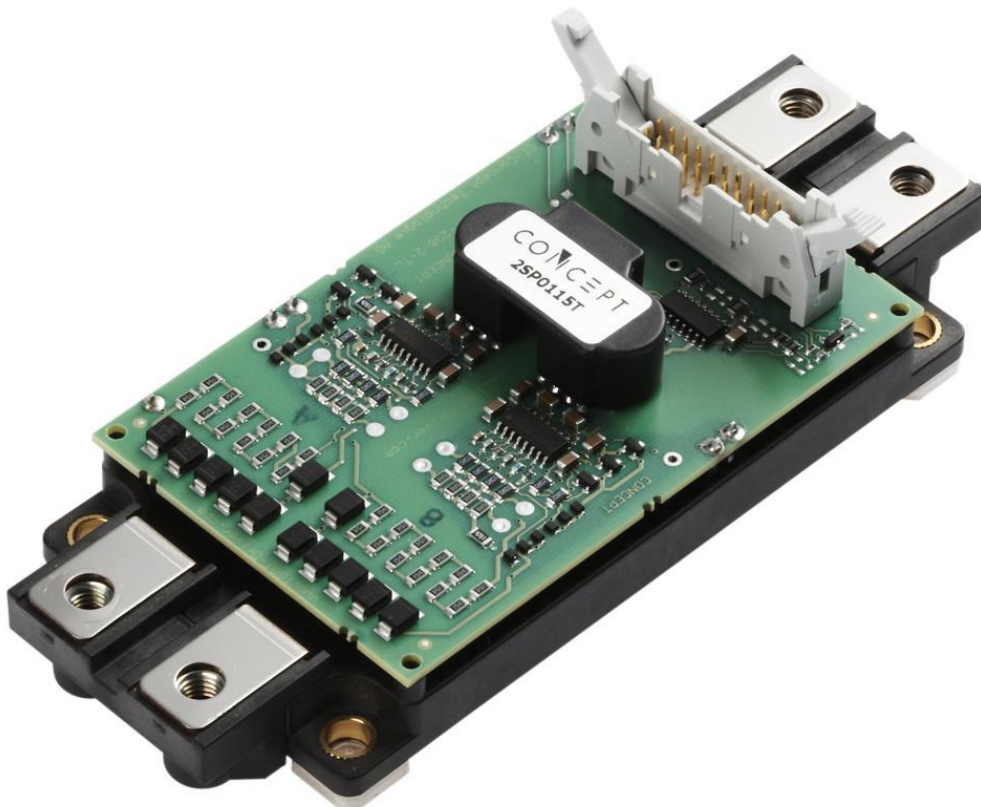

Fig. 1 2SP0115T soldered onto a 17mm dual IGBT module

Preliminary Description and Application Manual

Contents

System Overview	4
The Six Steps to Success.....	5
1. Choose a suitable driver	5
2. Attach the drivers to the IGBT modules.....	5
3. Connect the driver to the control electronics.....	5
4. Select the operating mode.....	5
5. Check the driver function.....	5
6. Set up and test the power stack	5
Mechanical Dimensions.....	6
Pin Designation of Connector X1	8
Recommended Interface Circuitry for Connector X1.....	8
Description of Interface X1.....	10
General	10
VCC terminal	10
MOD (mode selection)	10
INA, INB (channel drive inputs, e.g. PWM)	11
SO1, SO2 (status outputs).....	11
TB (input for adjusting the blocking time)	12
Description of Interface X2.....	12
NTC terminal	12
How Do 2SP0115T SCALE-2 Drivers Work in Detail?.....	13
Overview.....	13
Power supply and electrical isolation	14
Power-supply monitoring.....	14
V _{CE} monitoring / short-circuit protection	15
Dynamic behavior of IGBTs	15
Turn-on of the IGBT / commutation of diode current	15
Turn-off of the IGBT	16
Advanced Active Clamping.....	16
Parallel connection of 2SP0115T	17
3-level and multilevel topologies.....	19
Low-inductance layout	19
Bibliography	19
The Information Source: SCALE-2 Driver Data Sheets	20

Preliminary Description and Application Manual

Quite Special: Customized SCALE-2 Drivers 20

Technical Support 20

Quality..... 20

Legal Disclaimer 20

Ordering Information..... 21

Information about Other Products 21

Manufacturer..... 21

Preliminary Description and Application Manual

System Overview

The 2SP0115T are plug-and-play drivers based on the highly integrated SCALE-2 chipset developed by CONCEPT /1/. This is a set of application-specific integrated circuits (ASICs) that cover the main range of functions needed to design intelligent gate drivers. The SCALE-2 driver chipset is a further development of the proven SCALE technology /2/.

The basic topology of the 2SP0115T driver is shown in Fig. 2. The values for the gate resistors and other key components can be found in the specific datasheets for a given IGBT module /3/.

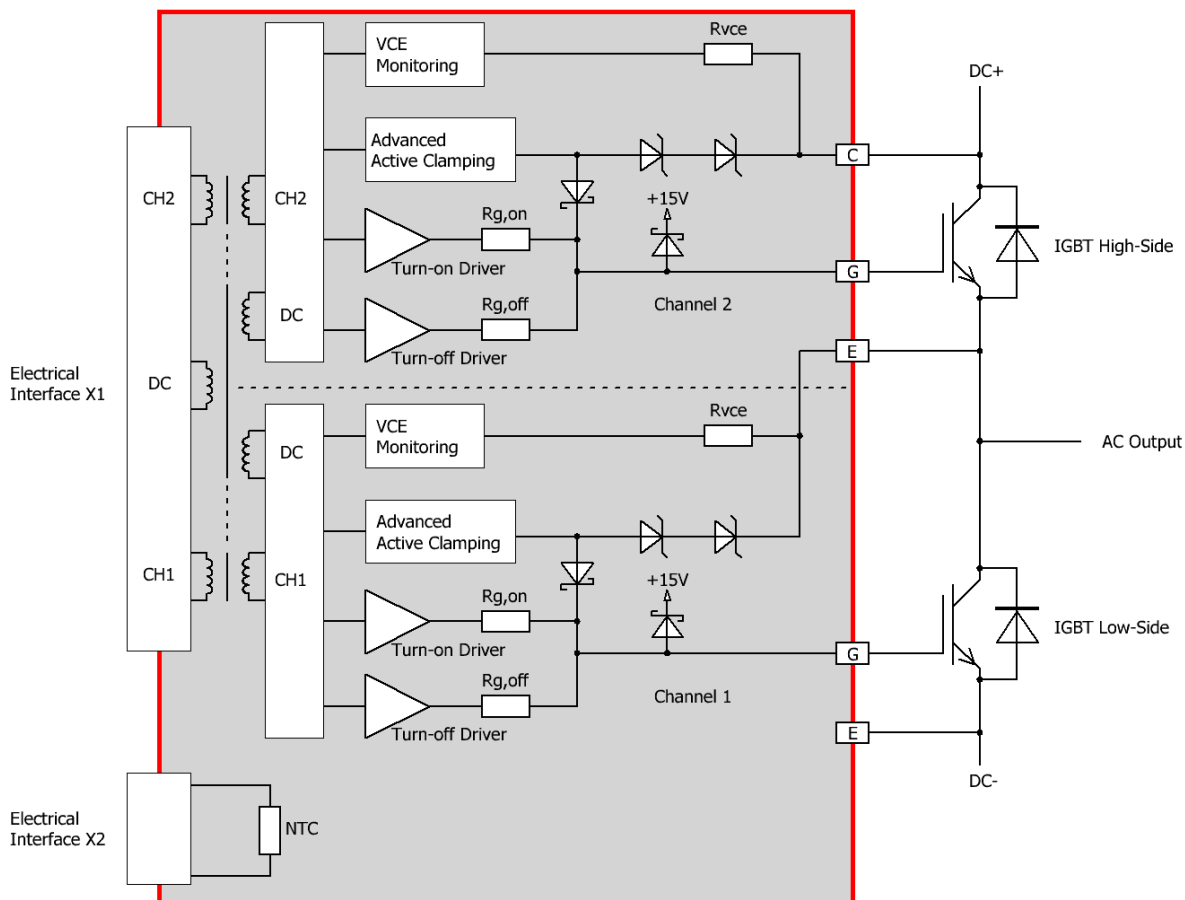

Fig. 2 Basic schematic of the 2SP0115T driver

The driver contains all necessary components for optimal and safe driving of the relevant IGBT module: smallest gate resistors in order to minimize switching losses, gate clamping, active-clamping diodes (overvoltage protection at turn-off), V_{CE} monitoring (short-circuit protection) as well as the input electrical connector X1. Moreover, it includes components for setting the turn-off trip level, the response time and the dead time between both channels in half-bridge mode. Its plug-and-play capability means that it is ready to operate immediately after mounting. The user needs invest no effort in designing or adjusting the driver to a specific application.

Preliminary Description and Application Manual

The Six Steps to Success

The following steps point out the easy way to use 2SP0115T drivers in power converters:

1. Choose a suitable driver

When applying 2SP0115T drivers, you should note that they are specifically adapted to a particular type of IGBT module.

The type designation of the driver consequently also includes a number corresponding to a specific IGBT module (see "Ordering Information").

These drivers are not valid for IGBT modules other than those specified. Incorrect use may result in failure.

2. Attach the drivers to the IGBT modules



Any handling of IGBT modules or drivers is subject to the general specifications for protecting electrostatic-sensitive devices according to international standard IEC 60747-1, Chapter IX or European standard EN 100015 (i.e. the workplace, tools, etc. must comply with these standards).

If these specifications are ignored, both IGBTs and drivers may be damaged.

The driver can be easily mounted onto an IGBT module by soldering the corresponding terminals.

3. Connect the driver to the control electronics

Connect the driver plug X1 to your control electronics and supply the driver with a voltage of 15V.

4. Select the operating mode

The operating mode can be set with input MOD (interface X1: pin 17). For details, see page 10).

5. Check the driver function

Check the gate voltage: For the off-state, the nominal gate voltage is specified in the relevant data sheet /3/. For the on-state, it is 15V. Also check the input current consumption of the driver without clock signals and at the desired switching frequency.

These tests should be performed before installation, as the gate terminals may otherwise not be accessible.

6. Set up and test the power stack

Before starting up the system, it is recommended that each IGBT module be checked separately under power-cycling conditions. It is usually sufficient to apply the single or double-pulse technique. CONCEPT specially

Preliminary Description and Application Manual

recommends users to check that the IGBT modules switch inside the SOA in the worst case condition, as this strongly depends on the specific converter construction.

Even if only single IGBTs are tested, all the system's gate drivers must be supplied with energy. All the other IGBTs are then kept in the off state by applying negative gate voltages. This is particularly important when switching the IGBTs under test.

The short-circuit behavior can also be verified at this point.

The system is then ready to start under real-world load conditions. This allows the thermal behavior of the whole arrangement to be determined.

The system must be re-qualified over the entire specified range of temperature and load conditions.



CAUTION: All handling with high voltages involves risk to life. It is imperative to comply with the respective safety regulations!

Mechanical Dimensions

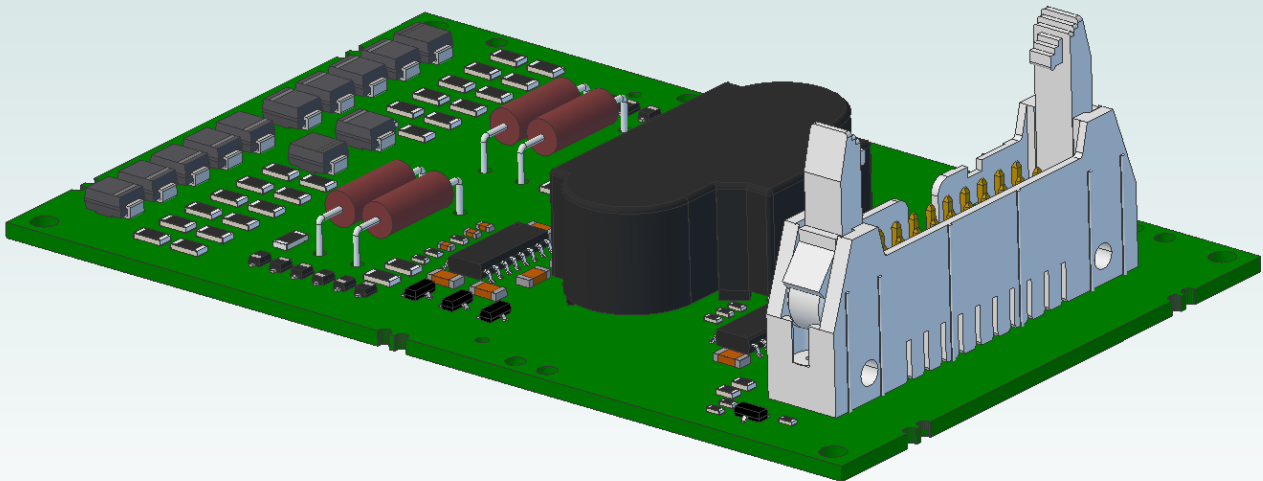
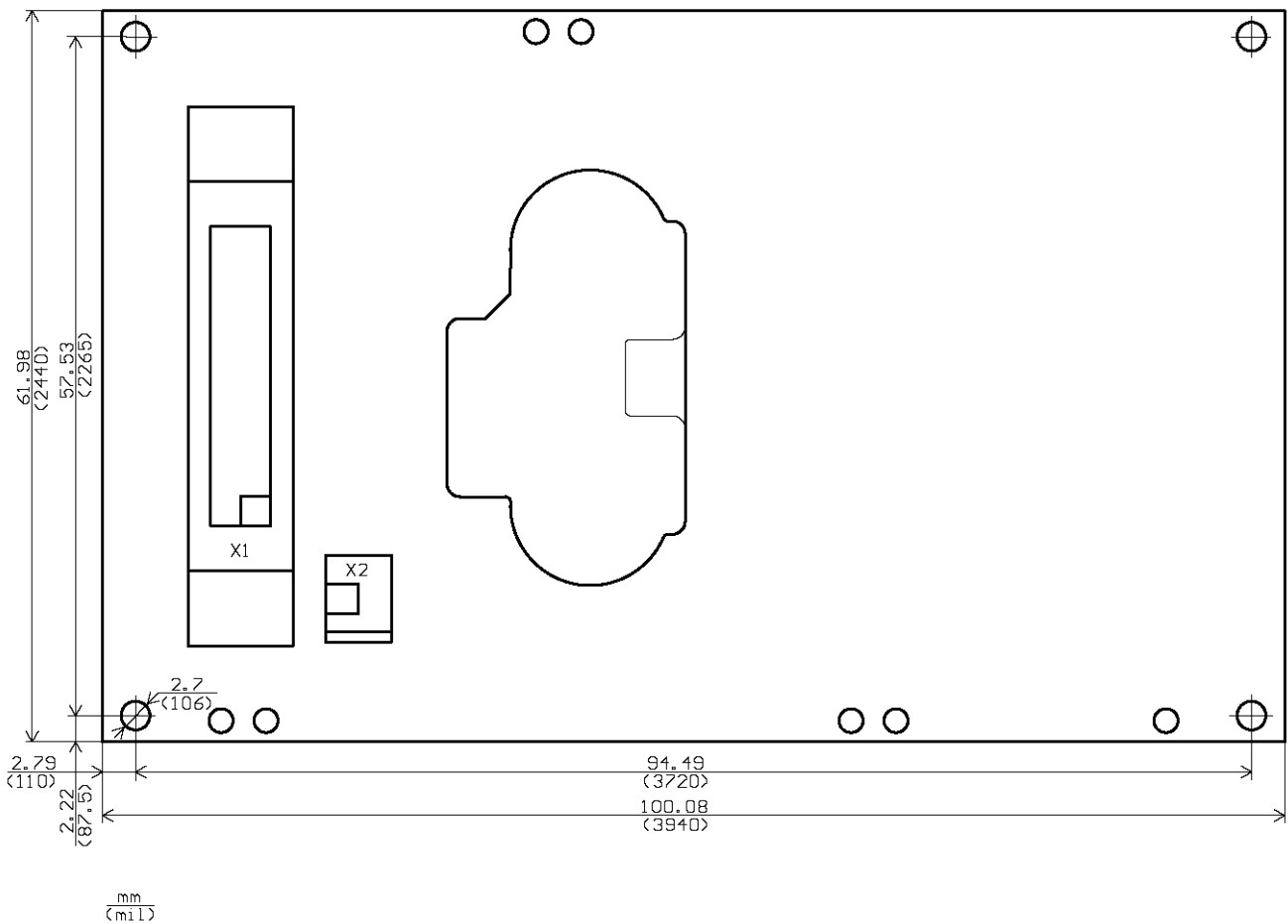
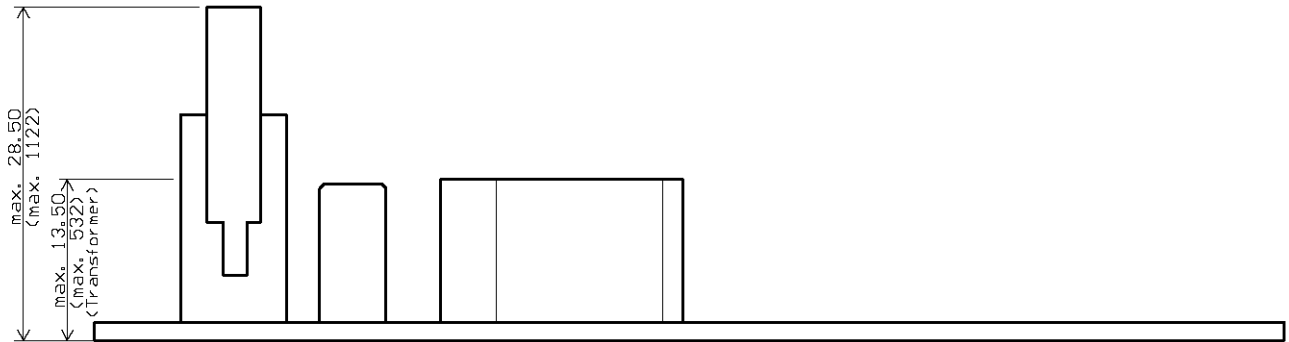

Fig. 3 Interactive 3D drawing of 2SP0115T

Preliminary Description and Application Manual



Electrical connector X1: 71918-120LF from FCI

Electrical connector X2: not assembled

Recommended cable connector: 71600-020LF from FCI

Recommended twisted pair flat cable: 1700/20 or 2100/20 from 3M™

Fig. 4 Mechanical dimensions of 2SP0115T

Preliminary Description and Application Manual

Pin Designation of Connector X1

Pin	Des.	Function	Pin	Des.	Function
1	N.C.	Not connected	2	GND	Ground
3	N.C.	Not connected	4	GND	Ground
5	VCC	15V supply voltage	6	GND	Ground
7	VCC	15V supply voltage	8	GND	Ground
9	SO2	Status output channel 2	10	GND	Ground
11	INB	Signal input B	12	GND	Ground
13	SO1	Status output channel 1	14	GND	Ground
15	INA	Signal input A	16	GND	Ground
17	MOD	Mode selection (direct/half-bridge)	18	GND	Ground
19	TB	Blocking time	20	GND	Ground

Recommended Interface Circuitry for Connector X1

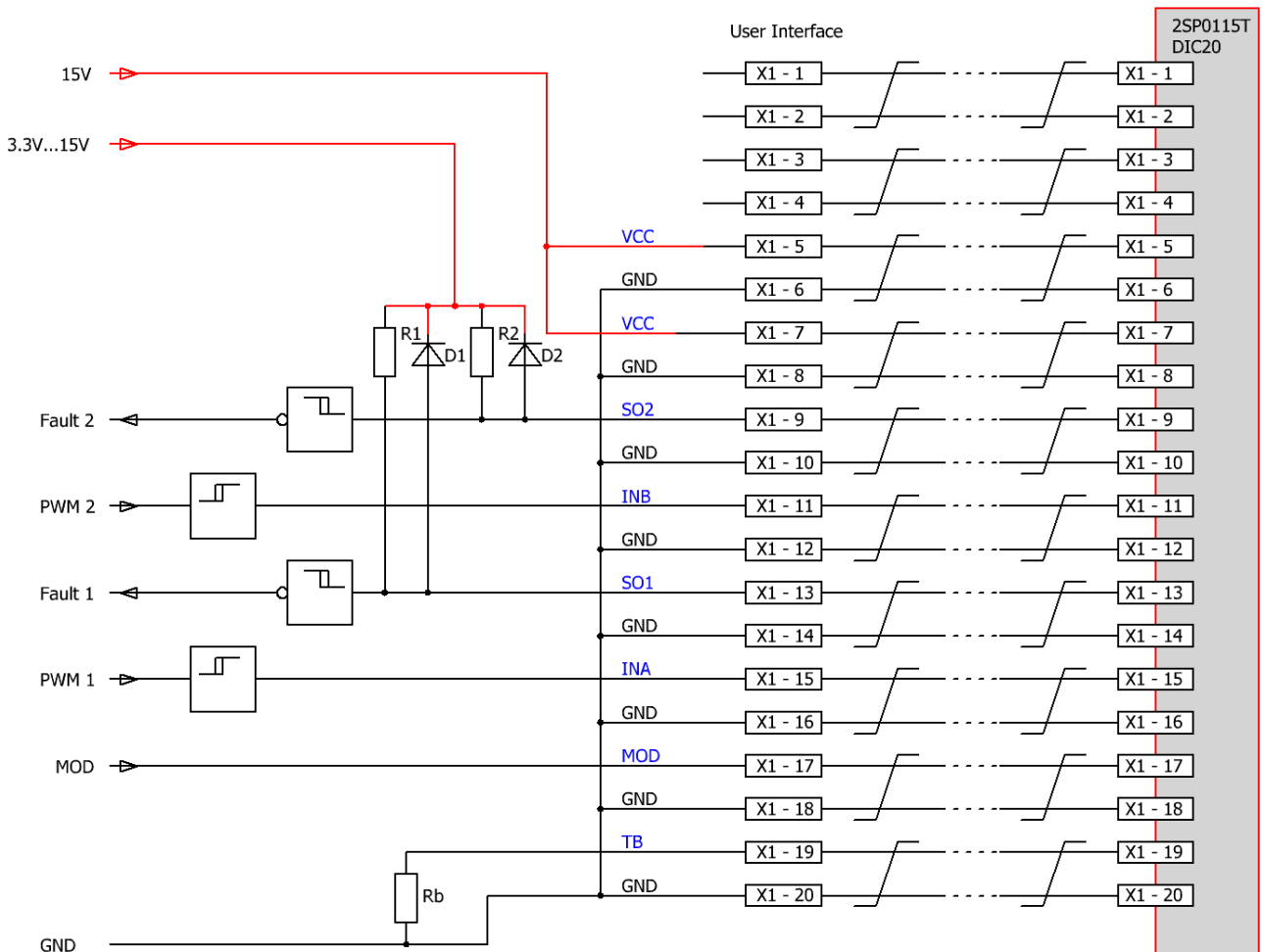

Fig. 5 Recommended user interface of 2SP0115T2Ax and 2SP0115T2Bx

Preliminary Description and Application Manual

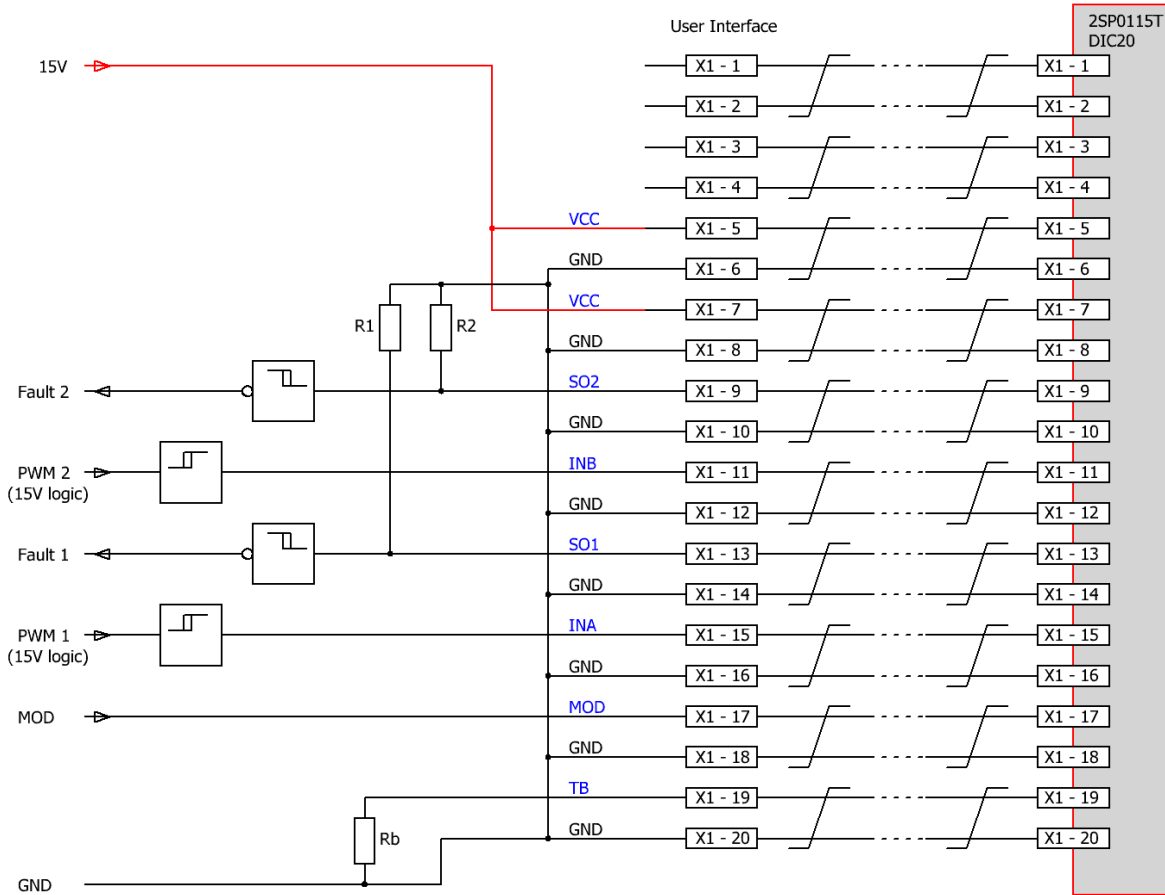

Fig. 6 Recommended user interface of 2SP0115T2Cx

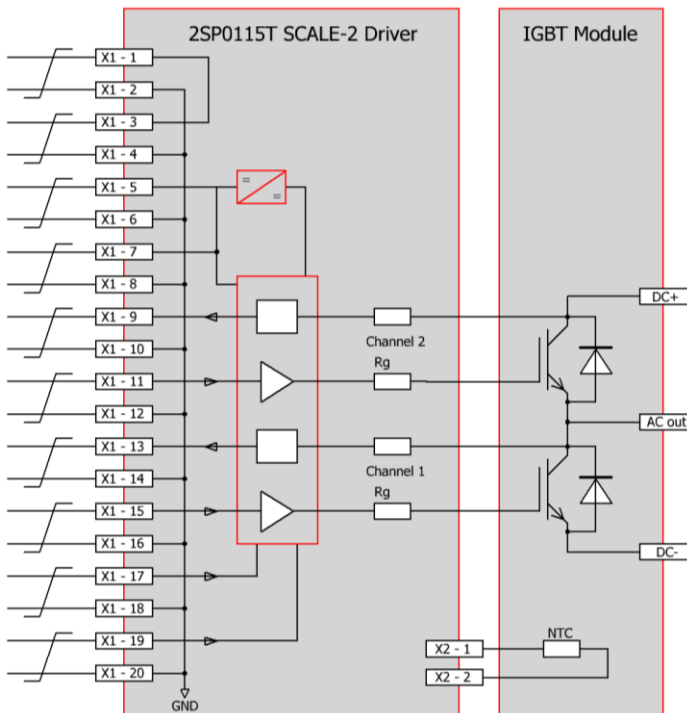

Fig. 7 Block diagram covering SCALE-2 driver 2SP0115T and IGBT module

Preliminary Description and Application Manual

Description of Interface X1

General

The interface X1 of the driver 2SP0115T is very simple and easy to use.

The driver has the following terminals:

- 2 x power-supply terminals (but only one 15V power supply is needed)
- 2 x drive signal inputs
- 2 x status outputs (fault returns)
- 1 x mode selection (half-bridge mode / direct mode)
- 1 x input to set the blocking time

The driver is equipped with a 20-pin interface connector. All even-numbered pins are used as GND connections. The odd-numbered pins are used as inputs or status outputs. It is recommended to use a 20-pin twisted flat cable. Each input and output signal is then twisted with its own GND wire. All GND pins are connected together on the 2SP0115T driver and should also be connected on the control-board side. This arrangement produces a very low-inductance connection with high immunity against interferences.

All inputs are ESD-protected. Moreover, all digital inputs have Schmitt-trigger characteristics.

VCC terminal

The driver has two VCC terminals on the interface connector to supply the primary side electronics and the DC-DC converters for the secondary sides.

As the driver can deliver a total power of $2 \times 1W = 2W$, the maximum input current drawn from the 15V supply is approx. 0.2A. The driver limits the inrush current at startup.

MOD (mode selection)

The MOD input allows the operating mode to be selected.

Direct mode

If the MOD input is not connected (floating), or connected to VCC, direct mode is selected. In this mode, there is no interdependence between the two channels. Input INA directly influences channel 1 while INB influences channel 2. High level at an input (INA or INB) always results in turn-on of the corresponding IGBT. This mode should be selected only when the dead times are generated by the control circuitry so that each IGBT receives its own drive signal.

Caution: Synchronous or overlapping timing of both switches of a half-bridge basically shorts the DC link.

Half-bridge mode

If the MOD input is low level (connected to GND), half-bridge mode is selected. In this mode, the inputs INA and INB have the following functions: INA is the drive signal input while INB acts as the enable input (see Fig. 8).

Preliminary Description and Application Manual

When input INB is low level, both channels are blocked. If it goes high, both channels are enabled and follow the signal on the input INA. At the transition of INA from low to high, Channel 2 turns off immediately and Channel 1 turns on after a dead time. The dead time is set by a resistor on the 2SP0115T.

Note that the dead time may vary from sample to sample. A tolerance of approximately $\pm 20\%$ may be expected. If higher timing precisions are required, CONCEPT recommends using direct mode and generating the dead time externally (refer to Application Note AN-1101 /7/).

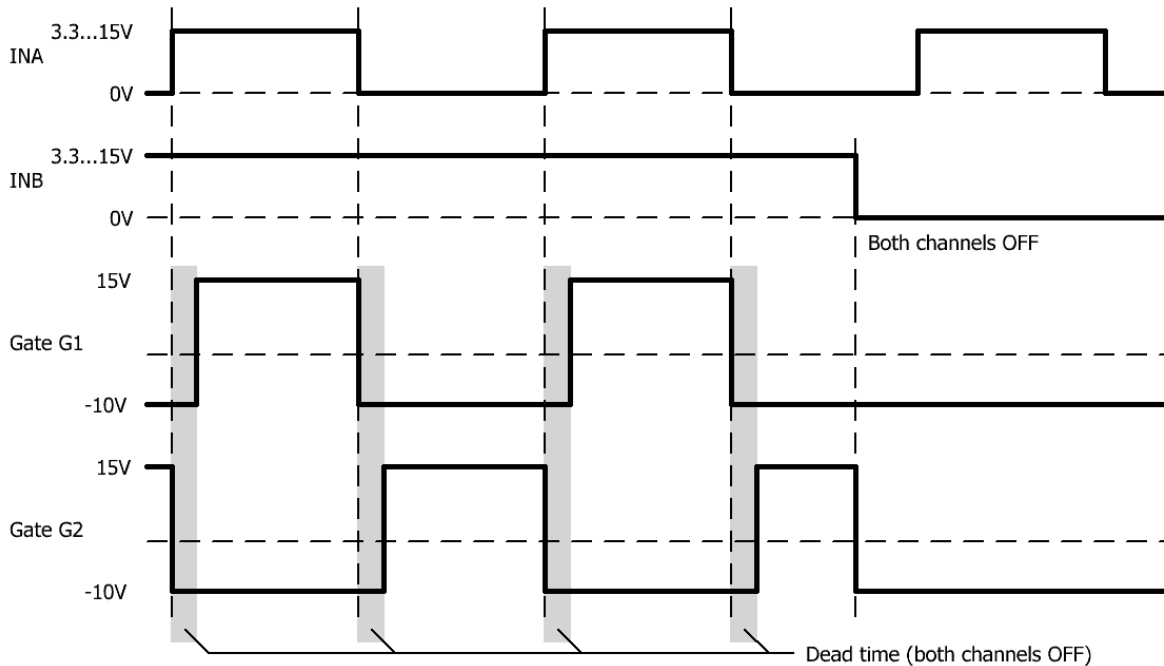

Fig. 8 Signals in half-bridge mode

INA, INB (channel drive inputs, e.g. PWM)

INA and INB are basically drive inputs, but their function depends on the MOD input (see above). 2SP0115T2Ax and 2SP0115T2Bx safely recognize signals in the whole logic-level range between 3.3V and 15V. They have built-in 4.7k Ω pull-down resistors. 2SP0115T2Cx safely recognize signals with a logic level of 15V. They have built-in voltage dividers with a total resistance of 4.5k Ω .

INA and INB feature Schmitt-trigger characteristics (see the specific datasheets for a given IGBT module /3/). An input transition is triggered at any edge of an incoming signal at INA or INB.

SO1, SO2 (status outputs)

The outputs SOx have open-drain transistors. They can be connected together to provide a common fault signal (e.g. for one phase). However, it is recommended to evaluate the status signals individually to allow fast and precise fault diagnosis.

The maximum SOx current in a fault condition should not exceed the value specified in the driver data sheets /3/.

Preliminary Description and Application Manual

2SP0115T2Ax/2SP0115T2Bx

When no fault condition is detected, the outputs have high impedance. An internal current source of 500µA pulls the SOx outputs to a voltage of about 4V when leaved open. When a fault condition is detected in channel "x", the status output SOx goes to low (connected to GND).

It is recommended to use the circuit shown in Fig. 5. The diodes D1 and D2 must be Schottky diodes and must only be used when using 3.3V logic. For 5V...15V logic, they can be omitted.

2SP0115T2Cx

When no fault condition is detected, an internal pull-up resistor of 10kΩ keeps the output voltage level at VCC. When a fault condition is detected, the corresponding status output SOx goes to low (connected to GND). It is recommended to use the circuit shown in Fig. 6. Both pull-down resistors R₁ and R₂ allow a missing SOx connection to be detected (safe logic in the event of a defective cable). Note that the resistors R₁ and R₂ must have a sufficiently high resistance value (e.g. 150kΩ), as they form a voltage divider together with the internal 10kΩ pull-up resistor on the driver.

How the status information is processed

- A fault on the secondary side (detection of short-circuit of IGBT module or supply undervoltage) is transmitted to the corresponding SOx output immediately. The corresponding SOx output is automatically reset after the blocking time Tb has elapsed (read the relevant data sheet for timing information /3/).
- A supply undervoltage on the primary side is indicated to both SOx outputs at the same time. Both SOx outputs are automatically reset when the undervoltage on the primary side disappears (read the relevant data sheet for timing information /3/).

TB (input for adjusting the blocking time)

The terminal TB allows the factory-set blocking time to be reduced by connecting an external resistor to GND (see Fig. 5 or Fig. 6). The following equation calculates the necessary resistor R_b connected between pins TB and GND in order to define the desired blocking time Tb (typical value):

$$R_b [k\Omega] = \frac{7650 + 150 \cdot Tb [ms]}{99 - Tb [ms]} - 6.8 \quad \text{where } 20ms < Tb < 90ms$$

The blocking time can also be set to a minimum of 9µs by selecting R_b=0Ω.

If not used, the input TB can be left open.

Description of Interface X2

NTC terminal

The driver has a non-insulated IGBT module NTC output on the interface connector X2. It is directly connected with the NTC thermistor of the IGBT module.

Preliminary Description and Application Manual

How Do 2SP0115T SCALE-2 Drivers Work in Detail?

Overview

The 2SP0115T series of plug-and-play dual-channel drivers are designed for 17mm dual IGBT modules. All drivers of the SCALE-2 driver family with an electrical interface are equipped with usual protection functions such as V_{CE} monitoring for short-circuit protection, operation inhibit after fault, supply-undervoltage shutdown and status feedback.

Outstanding features of 2SP0115T SCALE-2 drivers are: compact size, simple mounting - directly onto the IGBT module, Advanced Active Clamping function and very low propagation delay time. Active clamping describes an active scheme designed to protect the IGBTs against overvoltage during turn-off. It is particularly relevant when turning an IGBT off in cases of high DC-link voltage and collector current or short circuit. The 2SP0115T series also allows parallel operation of IGBT modules in order to increase the system power (see "Parallel connection of 2SP0115T" on page 17).

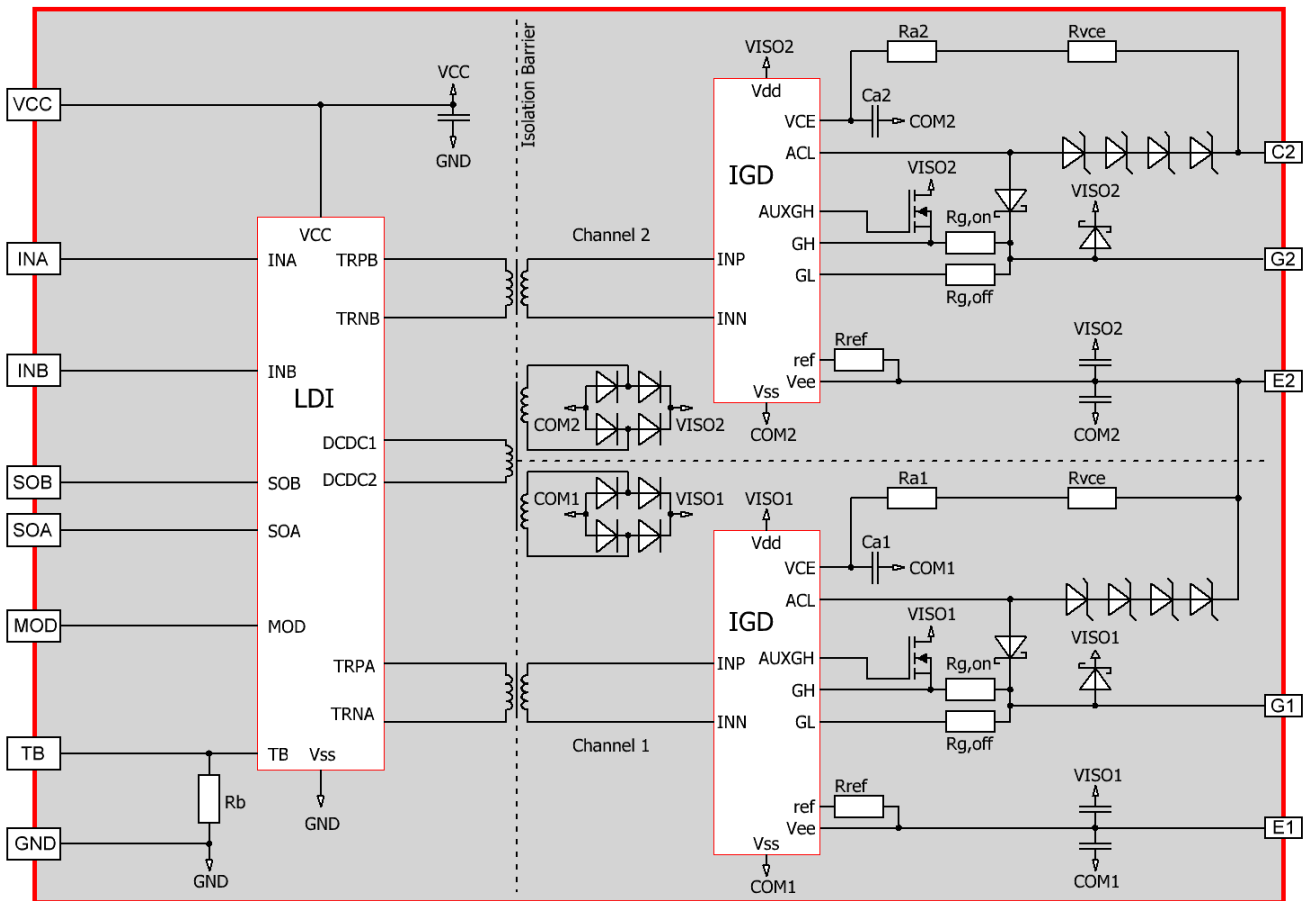

Fig. 9 Block diagram of the 2SP0115T SCALE-2 driver

Preliminary Description and Application Manual

Power supply and electrical isolation

The driver is equipped with a DC/DC converter to provide an electrically insulated power supply to the gate driver circuitry. The signal isolation is realized with transformers. All transformers (DC/DC and signal transformers) feature safe isolation to EN 50178, protection class II between primary side and either secondary side (refer to the data sheets /3/).

Note that the driver needs a stabilized supply voltage.

Power-supply monitoring

The driver's primary side as well as both secondary-side driver channels are equipped with a local undervoltage monitoring circuit.

In case of a primary-side supply undervoltage, both IGBTs are driven with a negative gate voltage to keep them in the off-state (both channels are blocked) and the fault is transmitted to both outputs SO1 and SO2 until the fault disappears.

In case of a secondary-side supply undervoltage, the corresponding IGBT is driven with a negative gate voltage to keep it in the off-state (the channel is blocked) and a fault condition is transmitted to the corresponding SOx output. The SOx output is automatically reset after the blocking time.

Even in the case of a low power supply voltage, the driver provides a low-impedance path from the IGBT gate to the emitter.

Within a half-bridge, it is advised not to operate the IGBTs with an IGBT driver in the event of a low supply voltage. Otherwise, a high rate of increase of V_{CE} may cause partial turn-on of these IGBTs.

Preliminary Description and Application Manual

V_{CE} monitoring / short-circuit protection

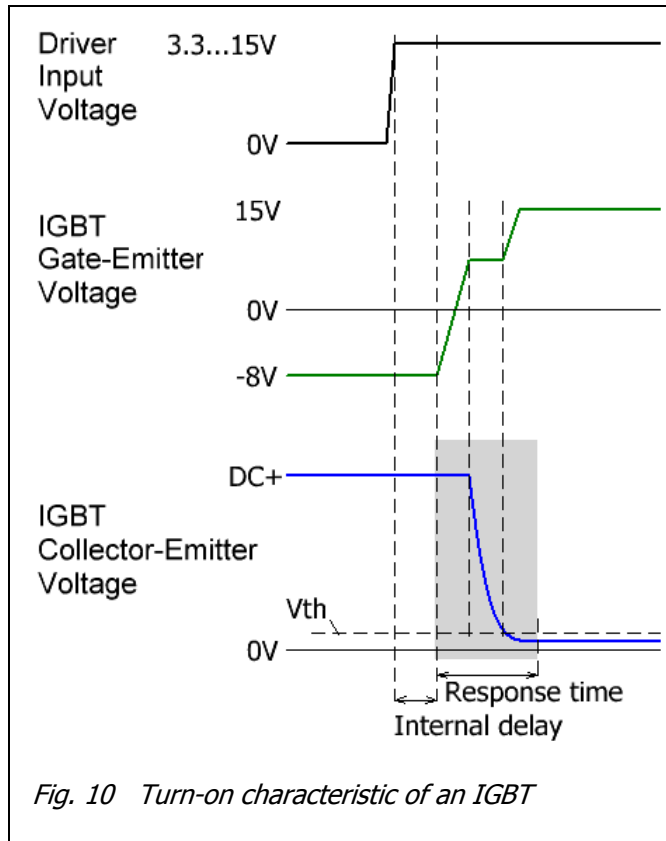

The basic V_{CE} monitoring circuit implemented in 2SP0115T SCALE-2 drivers is illustrated in Fig. 9. Both IGBT collector-emitter voltages are measured with a resistor network. V_{CE} is checked after the response time (see Fig. 10) at turn-on to detect a short circuit. If this voltage is higher than the programmed threshold V_{th} , the driver detects a short circuit at the IGBT and signals it immediately to the corresponding SOx output. After an additional delay, the corresponding IGBT is switched off. The IGBT is kept off (non-conducting) and the fault is shown at pin SOx as long as the blocking time is active.

The blocking time is applied independently to each channel. It starts when V_{CE} exceeds the threshold of the V_{CE} monitoring circuit.

It should be noted that the response time increases at DC-link voltages lower than about 550V (1200V and 1700V versions) or 400V (600V version). Please read the relevant driver data sheet for timing information /3/.

Note: The desaturation function is for short-circuit detection only and cannot provide overcurrent protection. However, overcurrent detection has a lower time priority and can be easily provided by the application.

Dynamic behavior of IGBTs

The dynamic behavior of IGBT modules depends on the type and manufacturer due to the particular behavior of the included IGBT and diode chips, the particular module construction and the distribution of internal gate resistances and inductances. Note that different module types from the same manufacturer may also require a specific gate-driver adaptation.

CONCEPT therefore supplies specific versions of SCALE-2 plug-and-play drivers adapted to the particular IGBT module. **These drivers must not be used with IGBT modules other than those for which they were specified.**

Turn-on of the IGBT / commutation of diode current

When a driver input goes high, the gate driver turns on the corresponding IGBT. The driver already includes the gate resistors, which are matched to the relevant IGBT module.

The driver is optimized to achieve minimum switching losses for the case of relatively low inductances within the power stack. It is recommended to check the commutation behavior within the final system assembly.

Preliminary Description and Application Manual

Turn-off of the IGBT

The IGBT is turned off when the corresponding input turns low. The gate resistors are determined by CONCEPT and must not be altered.

Fast turn-off of the IGBT may cause overvoltage, which increases with DC-link voltage or load current. The turn-off overvoltage can be approximated by:

$$V_{tr} = -L_s * di/dt$$

where V_{tr} is the turn-off overvoltage and L_s the stray inductance.

Most competing drivers are unable to limit the overvoltage in case of overload or short circuit. However, this is essential for high-power or high-voltage IGBTs. To solve this problem, SCALE-2 plug-and-play drivers provide an advanced Active Clamping function.

Advanced Active Clamping

Active clamping is a technique designed to partially turn on the IGBT in case the collector-emitter voltage exceeds a predefined threshold. The IGBT is then kept in linear operation. The basic circuit for active clamping can be found in /4/.

Basic active clamping topologies implement a single feedback path from the IGBT's collector through transient voltage suppressor devices (TVS) to the IGBT gate. The 2SP0115T SCALE-2 drivers support CONCEPT's Advanced Active Clamping based on this principle: when active clamping is activated, the turn-off MOSFET of the driver is switched off in order to improve the effectiveness of the active clamping and to reduce the losses in the TVS. This feature is mainly integrated in the secondary-side ASIC. The circuitry used is shown in Fig. 9.

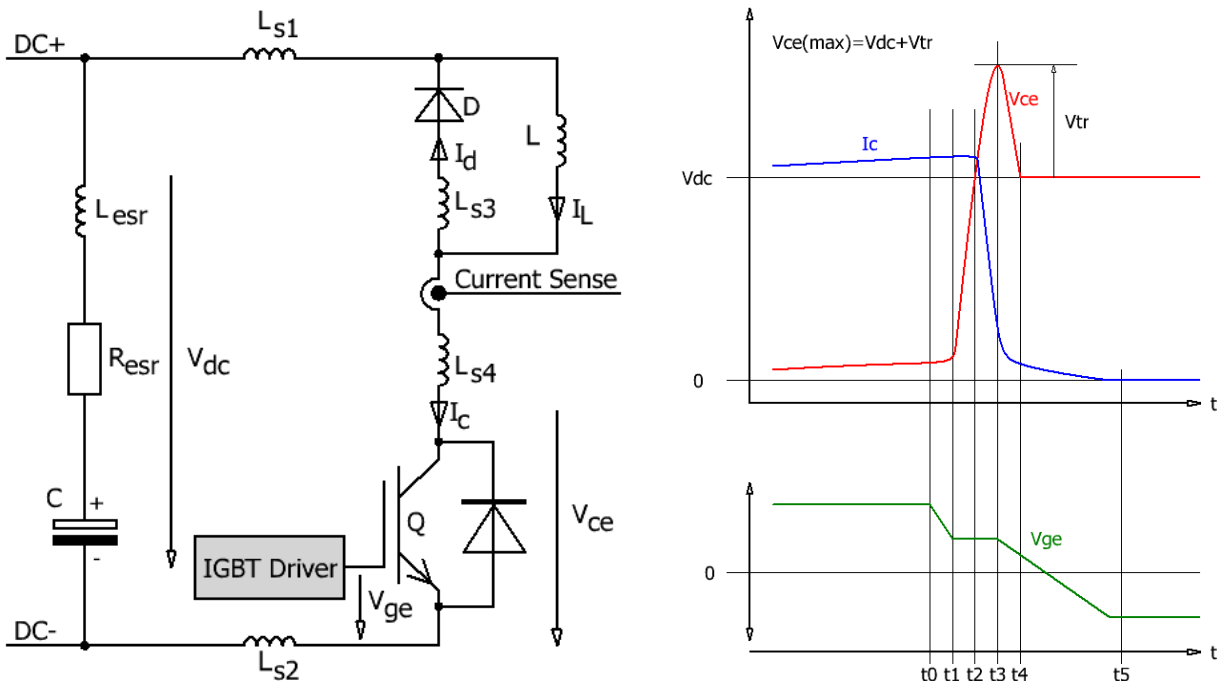

Fig. 11 Test circuit (left) and typical switching behavior (right)

Preliminary Description and Application Manual

Legend to Fig. 11

t0 = Initiation of the turn-off process
 t1 = Start of turn-off time
 t2 = Start of collector current fall time
 t3 = Maximum collector voltage
 t4 = IGBT is blocking, start of tail current
 t5 = End of tail current

In comparison with other driving methods, active clamping allows enhanced utilization of the IGBT modules during normal operation by increasing the switching speed and therefore reducing switching losses. The overvoltage at fault-current turn-off is also managed by active clamping. For the maximum permitted DC-link voltage, refer to the gate driver data sheets /3/.

Fig. 12 shows an exemplary turn-off transition of a 450A/1200V IGBT module controlled with a 2SP0115T driver.

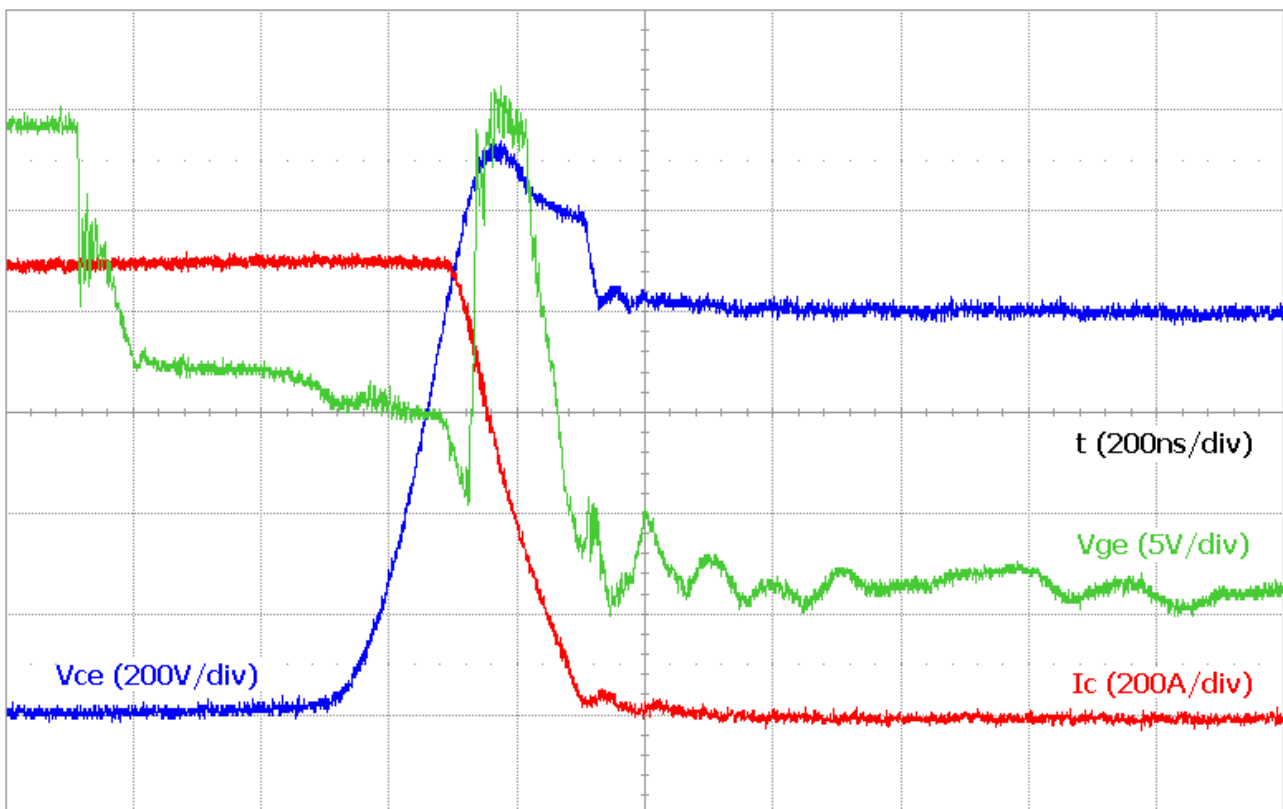

Fig. 12 Behavior of 450A/1200V IGBT module turning off at a DC-link voltage of 800V a collector current of 900A, which is twice the nominal collector current

Parallel connection of 2SP0115T

2SP0115T SCALE-2 drivers with the corresponding IGBT module can be paralleled in order to increase the system power. This outstanding feature results directly from the very low propagation delay of the driver as well as the low jitter (see the corresponding data sheets for timing information /3/ as well as /5/ for more information on paralleling).

CONCEPT recommends users to proceed in the following way to use 2SP0115T drivers in parallel operation:

Preliminary Description and Application Manual

- The supply voltage VCC of all parallel connected drivers must come from the same voltage source in order to ensure symmetrical operation of the drivers.
- Both input signals INA and INB of all parallel connected drivers must come from the same logic buffer (driver) in order to ensure very small delay differences.
- The slew rate of INA and INB must be high enough ($> 0.25\text{V/ns}$) in order to minimize the delay jitter. In particular, if the input signals INA and INB are filtered with an RC network (e.g. for short pulse suppression), a Schmitt trigger buffer must be used to generate a high slew rate at INA and INB.
- The length difference of the interface cables from the host board to the driver connectors X1 should be less than 40cm for all parallel-connected drivers in order to keep the additional delay differences below about 2ns.
- All drivers must work in direct mode. The half-bridge mode is not suitable for parallel operation of 2SP0115T.
- In case of fault turn-off, it is necessary to wait until the fault feedback of all paralleled drivers is reset in order to ensure that the blocking time of all paralleled drivers has elapsed.
- The status outputs SO1 and SO2 of parallel-connected drivers can be evaluated individually to allow precise fault diagnosis, or they can be connected together.

Normal operation

In normal switching operation (no fault feedback), the paralleled drivers can be used in the same way as without parallel connection. All paralleled IGBT modules are switched on and off synchronously. Laboratory measurements have shown that small signal delay differences ($<5\text{ns}$) as well as small differences of the negative gate voltage ($<0.4\text{V}$) lead to a small redistribution of the collector current at turn-off or turn-on as well as of the switching losses. However, this is a minor effect and asymmetry due to the mechanical construction of the converter will dominate in most cases.

Short circuit

In case of a short circuit, the first driver that detects the short circuit will send a fault feedback back to the corresponding SOx output. The corresponding IGBT will be switched off after an additional delay of about $1.4\mu\text{s}$. During this delay it is not possible to switch off the IGBT.

In the worst case condition, the user would (accidentally) try to switch off an IGBT module just after the short circuit has been detected by the first driver. In this case, the driver that has detected the short circuit would ignore the turn-off command. The drivers that have not yet detected the short circuit would turn the corresponding IGBTs off. This would lead to an asynchronous turn-off of the short circuit. However, laboratory measurements have shown that such asynchronous turn-off (delay difference up to $2\mu\text{s}$) does not reveal any problems. Both low-inductance ($\sim 70\text{nH}$) and high-inductance ($>1.5\mu\text{H}$) short circuits have been considered. However, CONCEPT recommends users to check this point in the specific application.

Supply undervoltage

In case of supply undervoltage, the corresponding driver will send a fault feedback back to the corresponding SOx output(s) and switch off the corresponding IGBT(s) immediately. It is then recommended to send a turn-off command to all paralleled drivers immediately. They will then switch off the corresponding IGBTs after a short delay.

Preliminary Description and Application Manual

3-level and multilevel topologies

If 2SP0115T drivers are to be used in 3-level or multilevel topologies, please refer to the Application Note AN-0901 /6/.

Low-inductance layout

The active-clamping function should not lead anyone to forget about the inductances of the power stack. For several reasons, it is still necessary to reduce the DC-link stray inductance to about 40nH...100nH with 2SP0115T plug-and-play drivers.

Bibliography

- /1/ Paper: Smart Power Chip Tuning, Bodo's Power Systems, May 2007
- /2/ "Description and Application Manual for SCALE™ Drivers", CONCEPT
- /3/ Data sheets SCALE™-2 plug-and-play driver 2SP0115Txxx-xxx, CONCEPT
- /4/ Paper: Driver Solutions for High-Voltage IGBTs, PCIM Europe Magazine, April 2002
- /5/ Paper: Intelligent Paralleling, Bodo's Power Systems, March 2009
- /6/ Application Note AN-0901: Methodology for Controlling Multi-Level Converter Topologies with SCALE™-2 IGBT Drivers, CONCEPT
- /7/ Application Note AN-1101: Application with SCALE™-2 Gate Driver Cores, CONCEPT

Note: The Application Notes are available on the Internet at www.igbt-driver.com/go/app-note and the papers at www.IGBT-Driver.com/go/paper

Preliminary Description and Application Manual

The Information Source: SCALE-2 Driver Data Sheets

CONCEPT offers the widest selection of gate drivers for power MOSFETs and IGBTs for almost any application needs. The largest website on gate-drive circuitry anywhere contains all data sheets, application notes and manuals, technical information and support sections: www.IGBT-Driver.com

Quite Special: Customized SCALE-2 Drivers

If you need an IGBT driver that is not included in the delivery range, please don't hesitate to contact CONCEPT or your CONCEPT sales partner.

CONCEPT has more than 25 years experience in the development and manufacture of intelligent gate drivers for power MOSFETs and IGBTs and has already implemented a large number of customized solutions.

Technical Support

CONCEPT provides expert help with your questions and problems:

www.IGBT-Driver.com/go/support

Quality

The obligation to high quality is one of the central features laid down in the mission statement of CT-Concept Technologie GmbH. The quality management system covers all stages of product development and production up to delivery. The drivers of the SCALE-2 series are manufactured to the ISO9001:2000 quality standard.

Legal Disclaimer

This data sheet specifies devices but cannot promise to deliver any specific characteristics. No warranty or guarantee is given – either expressly or implicitly – regarding delivery, performance or suitability.

CT-Concept Technologie GmbH reserves the right to make modifications to its technical data and product specifications at any time without prior notice. The general terms and conditions of delivery of CT-Concept Technologie GmbH apply.

Preliminary Description and Application Manual

Ordering Information

See the current list on www.IGBT-Driver.com/go/2SP0115T

Refer to www.IGBT-Driver.com/go/nomenclature for information on driver nomenclature

The general terms and conditions of delivery of CT-Concept Technologie GmbH apply.

Information about Other Products

For drivers adapted to other high-voltage or high-power IGBT modules

Direct link: www.IGBT-Driver.com/go/plug-and-play

For other drivers, evaluation systems product documentation and application support

Please click onto: www.IGBT-Driver.com

Manufacturer

CT-Concept Technologie GmbH
A Power Integrations Company
Johann-Renfer-Strasse 15
2504 Biel-Bienne
Switzerland

Phone +41 - 32 - 344 47 47

Fax +41 - 32 - 344 47 40

E-mail Info@IGBT-Driver.com

Internet www.IGBT-Driver.com

© 2009...2014 CT-Concept Technologie GmbH - Switzerland.

We reserve the right to make any technical modifications without prior notice.

All rights reserved.

Version 2.1 from 2014-03-24

Mouser Electronics

Authorized Distributor

Click to View Pricing, Inventory, Delivery & Lifecycle Information:

[Power Integrations:](#)

[2SP0115T2B](#)