

AVERY DENNISON MARKETING SPECIFICATION

THE SUBJECT MATTER DISCLOSED HEREIN EMBODIES PROPRIETARY INFORMATION WHICH IS THE CONFIDENTIAL PROPERTY OF THE AVERY DENNISON CO. NONE OF WHICH SHALL BE COPIED, REPRODUCED, DISCLOSED TO OTHERS, PUBLISHED OR USED IN WHOLE OR IN PART, FOR ANY PURPOSE OTHER THAN THAT FOR WHICH IT IS BEING MADE AVAILABLE WITHOUT THE EXPRESS ADVANCE WRITTEN PERMISSION OF A DULY AUTHORIZED AGENT OF THE COMPANY. THIS DOCUMENT IS THE PROPERTY OF THE AVERY DENNISON CO. AND IS TO BE RETURNED TO THE COMPANY ON DEMAND.

HISTORY

REV.	DATE	DESCRIPTION
N	07.15.09	UPDATE MATERIAL DESCRIPTION
O	09.23.14	CHG DIM 1 TO BE TAKEN FROM BOTTOM OF THE HEAD. MADE MM THE PRIMARY UNITS

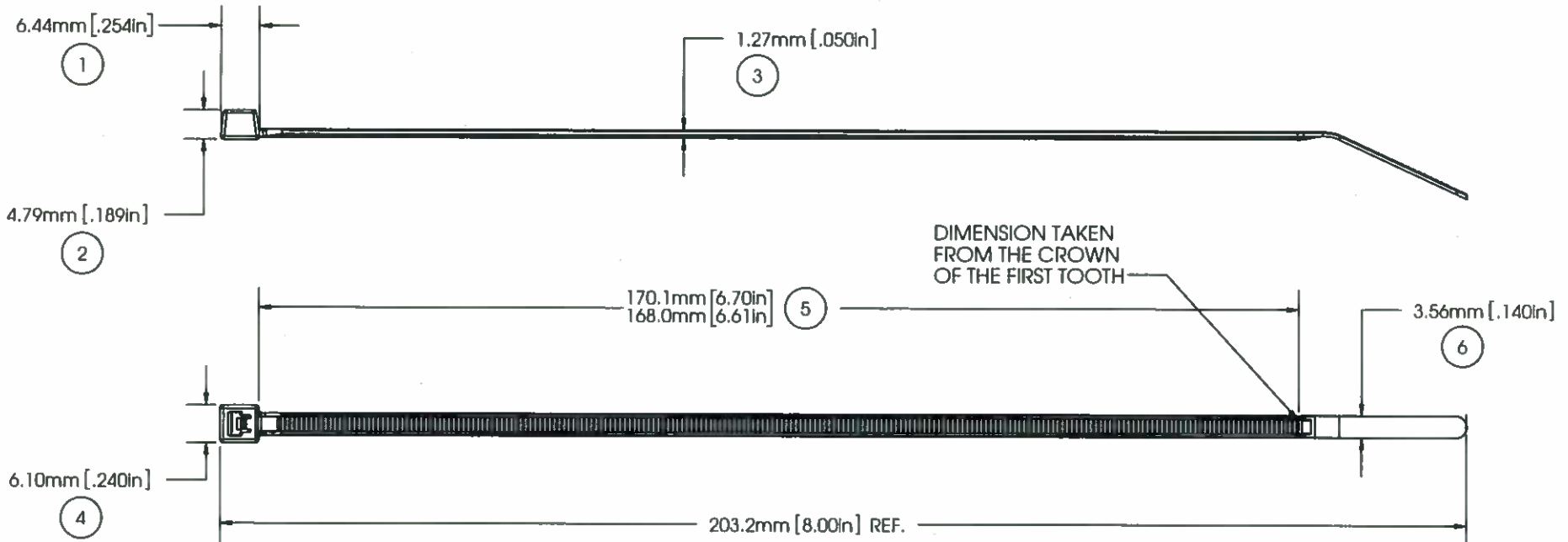

NOTE: THESE CABLE TIES ARE PLENUM RATED AND HAVE A FLAMMABILITY RATING OF V-2



MILITARY STANDARD:	MS-3367-5-4
LOOP TENSILE STRENGTH:	40 LBF / 180N MIN. PER AS-23190
OPERATING TEMP:	-40°F(-40°C) TO 185°F (85°C)
MIN. INSTALLATION TEMP:	32°F(0°C)
WEIGHT:	0.036 OZ./1.02 GRAMS
BUNDLE DIAMETER:	Ø 1.6MM TO Ø 54.0MM
TOOL:	12001 - HAND INSTALLATION TOOL 12500 - PNUM. INSTALLATION TOOL
TOOL TENSION SETTING:	3-5
PACKAGING:	1000/BAG, 5000/CASE

APPROVALS: ENG. APPR. *L. J. O'Neil* 9/23/14
Q.A. APPR. *J. Boyle* 9/23/14

SPECIFIED TOLERANCES ARE:
 .XX ± .03 IN. .X ± .7 MM
 .XXX ± .010 IN. .XX ± .25 MM
 ANGULAR: ± 2°

MATERIAL: NYLON 6/6
 COLOR: YELLOW

AVERY DENNISON <small>FASTENER DIVISION FITCHBURG, MA 01420 U.S.A. TEL. 1-800-225-5913 FAX. 978-353-9157</small>	DESCRIPTION	STOCK NO.	REV.
	8" CABLE TIE, INTERMED.	08782-0	O

Mouser Electronics

Authorized Distributor

Click to View Pricing, Inventory, Delivery & Lifecycle Information:

[Avery Dennison:](#)

[08782-0](#)