

General Description

The SY82802 high efficiency 600kHz synchronous buck converter operates over a wide input voltage range of 4.5V to 30V, and can deliver an output current up to 2A. It integrates a top MOSFET and a bottom MOSFET with very low $R_{DS(ON)}$ to minimize conduction loss. The 600kHz pseudo-constant switching frequency enables using small external inductor and capacitor values.

The SY82802 uses advanced constant on-time and ripple-based control strategy to achieve fast transient response for applications with high step-down ratios, and high efficiency at light loads. It also provides cycle-by-cycle current limit protection, output under voltage protection and over temperature protection.

Only the input and output capacitors, inductor, feedback resistor divider and feedforward capacitor need to be selected for the targeted application specifications.

The SY82802 is available in a compact SOT23-6 package.

Features

- Low $R_{DS(ON)}$ for Internal MOSFETs: 150mΩ Top, 115mΩ Bottom
- Wide Input Voltage Range: 4.5V ~ 30V
- Up to 2A Output Current
- $\pm 1\%$ 0.6V Reference over Temperature from -40°C to 125°C
- Precise EN Threshold
- PFM Light Load Operation for High Efficiency
- Internal Soft-Start Limits the Inrush Current
- Support Smooth Startup with Pre-Biased Output
- 600kHz Switching Frequency Minimizes the External Components
- Advanced Constant On-time and Ripple-Based Control to Achieve Fast Transient Responses
- Cycle-by-Cycle Valley and Peak Current Limit Protection
- Hic-Cup Mode Output Under Voltage Protection
- Auto-Recovery Mode Over Temperature Protection
- Input Under Voltage Lockout (UVLO)
- RoHS-Compliant and Halogen-Free
- Compact Package: SOT23-6

Applications

- Set Top Box
- Portable TV
- DSL Modem
- LCD TV
- IP CAM
- Networking

Typical Application

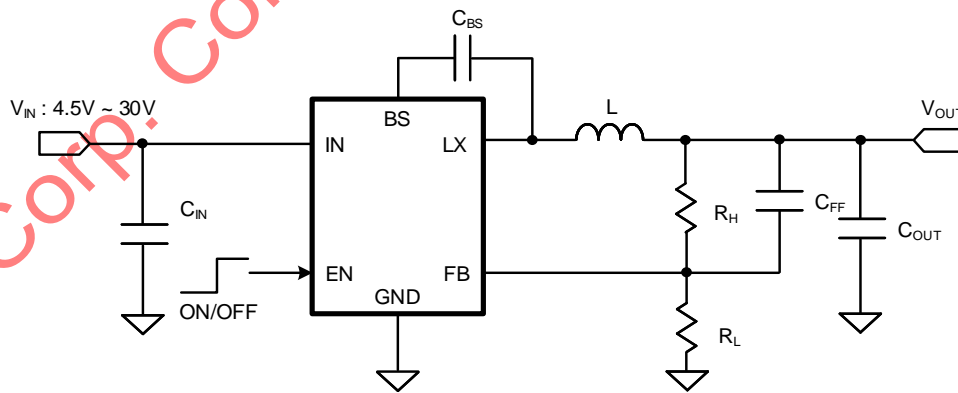

Figure 1. Schematic Diagram



Ordering Information

Ordering Part Number	Package Type	Top Mark
SY82802ABT	SOT23-6 RoHS Compliant and Halogen Free	n2xyz

x = year code, y = week code, z = lot number code

Pinout (top view)

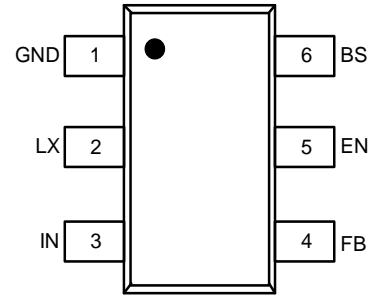

Pin No	Pin Name	Pin Description
1	GND	Ground pin.
2	LX	Inductor pin. Connect this pin to the switching node of inductor.
3	IN	Input pin. Decouple this pin from the GND pin with at least a 10μF ceramic capacitor.
4	FB	Output feedback pin. Connect this pin to the center point of the output resistor divider as shown in Figure 1. $V_{OUT} = 0.6 \times (1 + R_H/R_L)$.
5	EN	Enable pin. Pull this pin higher than EN rising threshold to turn on the device and pull this pin lower than EN falling threshold to turn off the device. Do not leave this pin floating.
6	BS	Bootstrap pin. Supply top MOSFET gate driver. Connect a 0.1μF ceramic capacitor between BS and LX pin.

Silergy Corp. Confidential Prepared for Customer Use Only

Block Diagram

Figure3. Block Diagram

Absolute Maximum Ratings

Parameter (Note 1)	Min	Max	Unit
IN	-0.3	32	V
EN, LX	-0.3	IN + 0.3	
FB, BS-LX	-0.3	4	
LX, 10ns Duration	-5	IN + 3	
Junction Temperature, Operating	-40	150	°C
Lead Temperature (Soldering, 10s)		260	
Storage Temperature	-65	150	

Thermal Information

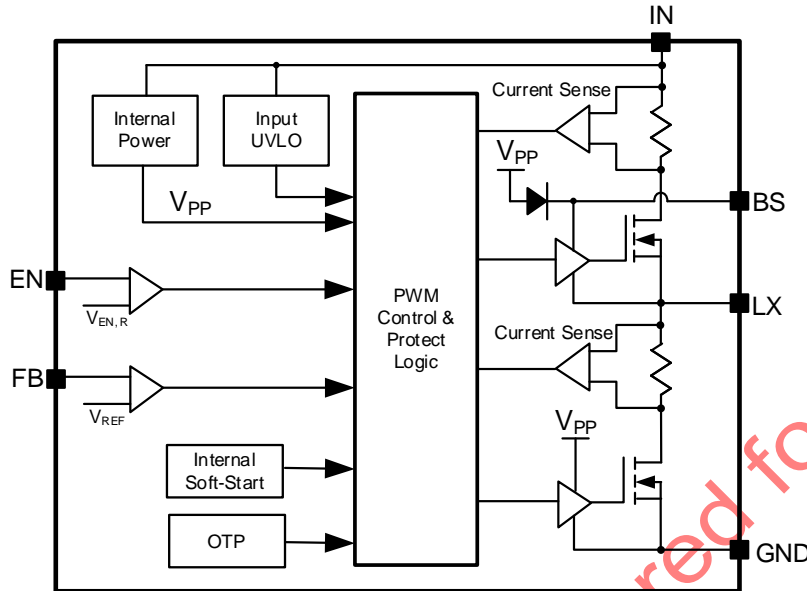
Parameter (Note 2)	Typ	Unit
θ_{JA} Junction-to-Ambient Thermal Resistance	58	°C/W
θ_{JC} Junction-to-Case Thermal Resistance	4.7	
P_D Power Dissipation $T_A = 25^\circ\text{C}$	1.72	W

Recommended Operating Conditions

Parameter (Note 3)	Min	Max	Unit
Input Voltage	4.5	30	V
Output Voltage	0.6	12.5	
Continuous Output Current		2	A
Junction Temperature, Operating	-40	125	°C
Ambient Temperature	-40	85	

Electrical Characteristics

($V_{IN} = 12V$, $V_{OUT} = 3.3V$, $L = 6.8\mu H$, $C_{OUT} = 22\mu F$, $T_J = 25^\circ C$, $I_{OUT} = 1A$ unless otherwise specified)

Parameter	Symbol	Test Conditions	Min	Typ	Max	Unit	
Input	Voltage Range	V_{IN}	4.5		30	V	
	UVLO Rising Threshold	$V_{IN,UVLO}$	V_{IN} rising		4.45		
	UVLO Hysteresis	$V_{IN,HYS}$		0.3			
	Shutdown Current	I_{SHDN}	$V_{EN} = 0V$		8	12	μA
	Quiescent Current	I_Q	$I_{OUT} = 0A$, $V_{FB} = V_{REF} \times 105\%$		250		
Output	Voltage Range	V_{SET}	0.6		12.5	V	
	FB Reference Voltage	V_{REF}	$T_J = -40^\circ C \sim 125^\circ C$	0.594	0.6	0.606	
	FB Input Current	I_{FB}	$V_{FB} = 1V$	-50		50	nA
	Turn On Delay Time	$t_{ON,DLY}$	From EN high to LX starts switching (Note 4)		180		μs
	Soft-Start Time	t_{SS}	V_{OUT} from 0% to 100% V_{SET}		1		ms
	UVP Threshold	V_{UVP}			33		$\%V_{REF}$
	UVP Delay Time	$t_{UVP,DLY}$			150		μs
	UVP Hiccup On-Time	$t_{UVP,ON}$			1.4		ms
	UVP Hiccup Off-Time	$t_{UVP,OFF}$			9.8		
Enable (EN)	Rising Threshold	$V_{EN,R}$	1.12	1.2	1.28	V	
	Falling Threshold	$V_{EN,F}$	0.95	1.0	1.05		
	Input Current	I_{EN}	$V_{EN} = 3.3V$		0		μA
MOSFET	Top MOSFET $R_{DS(ON)}$	$R_{DS(ON),TOP}$		150		m Ω	
	Bottom MOSFET $R_{DS(ON)}$	$R_{DS(ON),BOT}$		115			
	Top MOSFET Current Limit Threshold	$I_{LMT,TOP}$		3	4.5	A	
	Bottom MOSFET Current Limit Threshold	$I_{LMT,BOT}$		2	3		
Frequency	Switching Frequency	f_{SW}	$I_{OUT} = 1A$, CCM		600		kHz
	Minimum On-Time	$t_{ON,MIN}$			40		ns
	Minimum Off-Time	$t_{OFF,MIN}$			120		
OTP	Temperature	T_{OTP}	(Note 4)		160		$^\circ C$
	Temperature Hysteresis	T_{HYS}	(Note 4)		15		

Note 1: Stresses beyond the “Absolute Maximum Ratings” may cause permanent damage to the device. These are stress ratings only. Functional operation of the device at these or any other conditions beyond those indicated in the operational sections of the specification is not implied. Exposure to absolute maximum rating conditions for extended periods may affect device reliability.

Note 2: θ_{JA} is measured in the natural convection at $T_A = 25^\circ C$ on a 6cmx6cm size, two-layer Silergy Evaluation Board with 2-oz copper. Pin 2 of SOT23-6 package is the case position for θ_{JC} measurement.

Note 3: The device is not guaranteed to function outside its operating conditions.

Note 4: Guaranteed by design.

SOT23-6 Package Outline and PCB layout

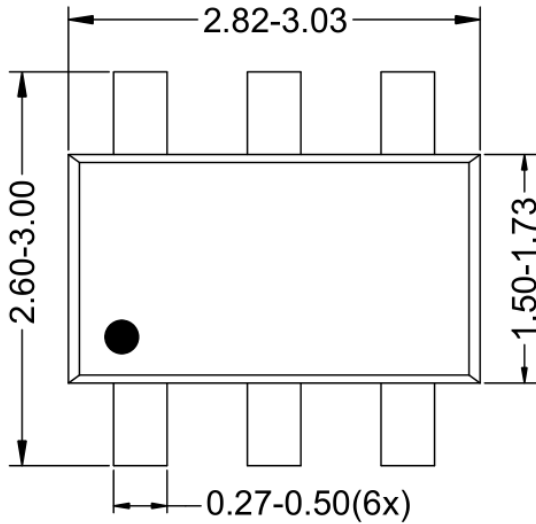

Top View

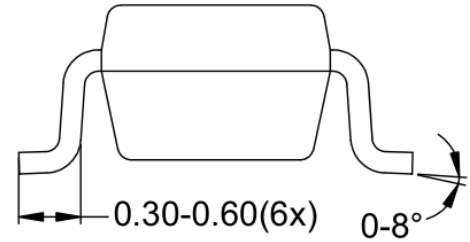

Side View

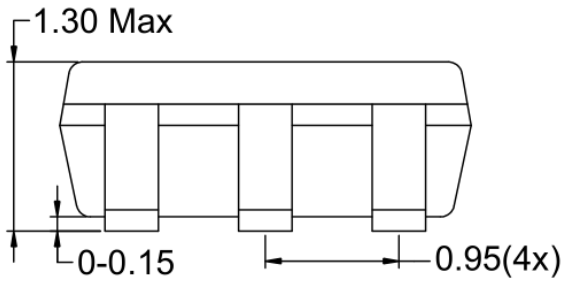

Side View

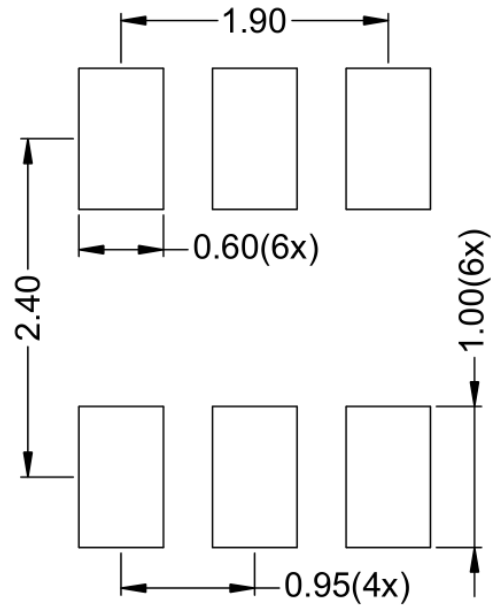

Recommended PCB Layout

Notes: All dimension in millimeter and exclude mold flash & metal burr.

Tape and Reel Information

1. Tape dimensions and pin 1 orientation

SOT23-6

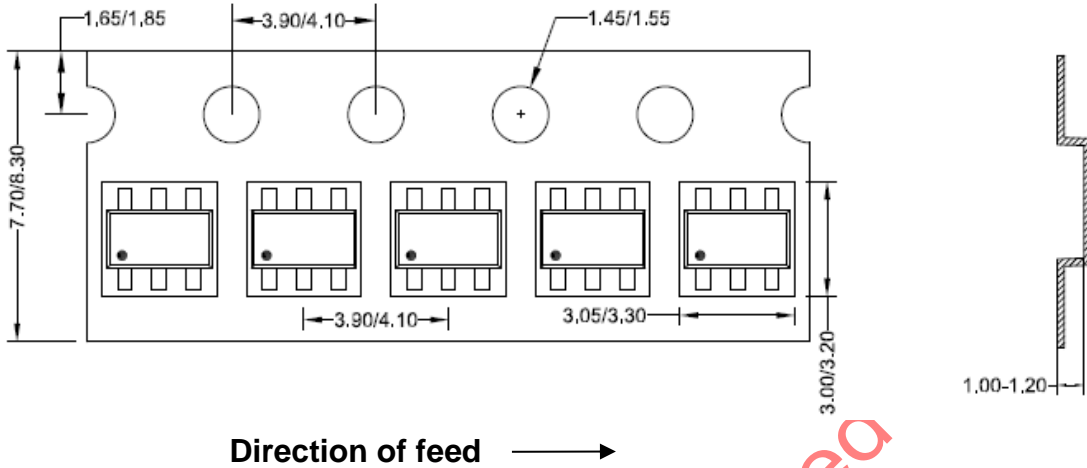

2. Reel dimensions

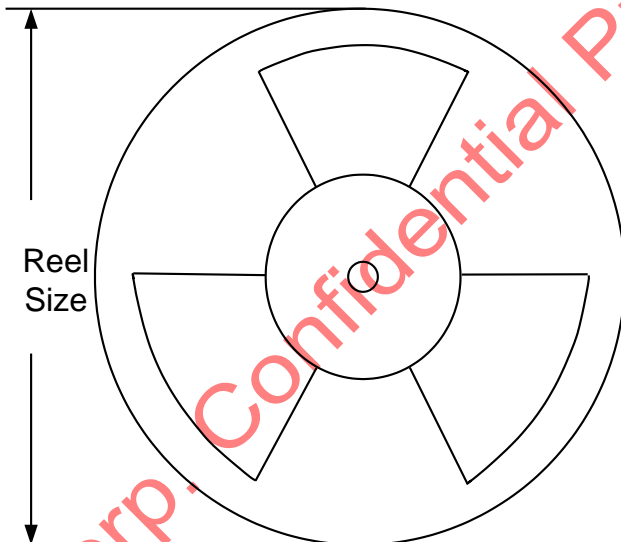

Package type	Tape width (mm)	Pocket pitch(mm)	Reel size (Inch)	Trailer length(mm)	Leader length (mm)	Qty per reel
SOT23-6	8	4	7"	400	160	3000

3. Others: NA.

IMPORTANT NOTICE

- 1. Right to make changes.** Silergy and its subsidiaries (hereafter Silergy) reserve the right to change any information published in this document, including but not limited to circuitry, specification and/or product design, manufacturing or descriptions, at any time and without notice. This document supersedes and replaces all information supplied prior to the publication hereof. Buyers should obtain the latest relevant information before placing orders and should verify that such information is current and complete. All semiconductor products are sold subject to Silergy's standard terms and conditions of sale.
- 2. Applications.** Application examples that are described herein for any of these products are for illustrative purposes only. Silergy assume no liability for any application assistance or designs of customer products. It is customer's sole responsibility to determine whether the Silergy product is suitable and fit for the customer's applications and products planned. To minimize the risks associated with customer's products and applications, customer should provide adequate design and operating safeguards. Customer represents and makes no representation or warranty that such applications will be suitable for the specified use without further testing or modification. Buyers are responsible for the design and operation of their applications and products using Silergy products. Silergy or its subsidiaries agrees that it has all the necessary expertise to create and implement safeguards which anticipate dangerous consequences of failures, monitor failures and their consequences, lessen the likelihood of failures that might cause harm and take appropriate remedial actions. Silergy assumes no liability related to any default, damage, costs or problem in the customer's applications or products, or the application or use by customer's third-party buyers. Customer will fully indemnify Silergy, its subsidiaries, and their representatives against any damages arising out of the use of any Silergy components in safety-critical applications. It is also buyers' sole responsibility to warrant and guarantee that any intellectual property rights of a third party are not infringed upon when integrating Silergy products into any application. Silergy assumes no responsibility for any said applications or for any use of any circuitry other than circuitry entirely embodied in a Silergy product.
- 3. Limited warranty and liability.** Information furnished by Silergy in this document is believed to be accurate and reliable. However, Silergy makes no representation or warranty, expressed or implied, as to the accuracy or completeness of such information and shall have no liability for the consequences of use of such information. In no event shall Silergy be liable for any indirect, incidental, punitive, special or consequential damages, including but not limited to lost profits, lost savings, business interruption, costs related to the removal or replacement of any products or rework charges, whether or not such damages are based on tort or negligence, warranty, breach of contract or any other legal theory. Notwithstanding any damages that customer might incur for any reason whatsoever, Silergy' aggregate and cumulative liability towards customer for the products described herein shall be limited in accordance with the Standard Terms and Conditions of Sale of Silergy.
- 4. Suitability for use.** Customer acknowledges and agrees that it is solely responsible for compliance with all legal, regulatory and safety-related requirements concerning its products, and any use of Silergy components in its applications, notwithstanding any applications-related information or support that may be provided by Silergy. Silergy products are not designed, authorized or warranted to be suitable for use in life support, life-critical or safety-critical systems or equipment, nor in applications where failure or malfunction of an Silergy product can reasonably be expected to result in personal injury, death or severe property or environmental damage. Silergy assumes no liability for inclusion and/or use of Silergy products in such equipment or applications and therefore such inclusion and/or use is at the customer's own risk.
- 5. Terms and conditions of commercial sale.** Silergy products are sold subject to the standard terms and conditions of commercial sale, as published at <http://www.silergy.com/stdterms>, unless otherwise agreed in a valid written individual agreement specifically agreed to in writing by an authorized officer of Silergy. In case an individual agreement is concluded only the terms and conditions of the respective agreement shall apply. Silergy hereby expressly objects to and denies the application of any customer's general terms and conditions with regard to the purchase of Silergy products by the customer.
- 6. No offer to sell or license.** Nothing in this document may be interpreted or construed as an offer to sell products that is open for acceptance or the grant, conveyance or implication of any license under any copyrights, patents or other industrial or intellectual property rights. Silergy makes no representation or warranty that any license, either express or implied, is granted under any patent right, copyright, mask work right, or other intellectual property right. Information published by Silergy regarding third-party products or services does not constitute a license to use such products or services or a warranty or endorsement thereof. Use of such information may require a license from a third party under the patents or other intellectual property of the third party, or a license from Silergy under the patents or other intellectual property of Silergy.

For more information, please visit: www.silergy.com

©2024 Silergy Corp.

All Rights Reserved.