

Description

The SL6106SE is a high-efficiency 1.5MHz synchronous step down DC/DC regulator IC capable of delivering up to 1.5A output current. The device is available in an adjustable version. Supply current with no load is 40uA and drops to <1uA in shutdown. The 2.7V to 5.5V input voltage range makes the SL6106SE ideally suited for single Li-Ion battery powered applications. 100% duty cycle provides low dropout operation, extending battery life in portable systems. PWM/PFM mode operation provides very low output ripple voltage for noise sensitive applications.

Features

- Up to 1.5A Current Output
- High Efficiency: Up to 96%
- 2.7V to 5.5V Input Voltage Range
- 1.5MHz Constant Frequency Operation
- No Schottky Diode Required
- Low Dropout Operation:100% Duty Cycle
- PFM Mode for High Efficiency in Light Load
- Low Quiescent Current: 40μA
- Over temperature Protected
- Short Circuit Protection
- Inrush Current Limit and Soft Start
- SOT-23-5 Package

Applications

- Cellular and Smart Phones
- Wireless and DSL Modems
- Battery-Powered Equipment
- Portable Media Player (PMP)

Typical Application Circuit

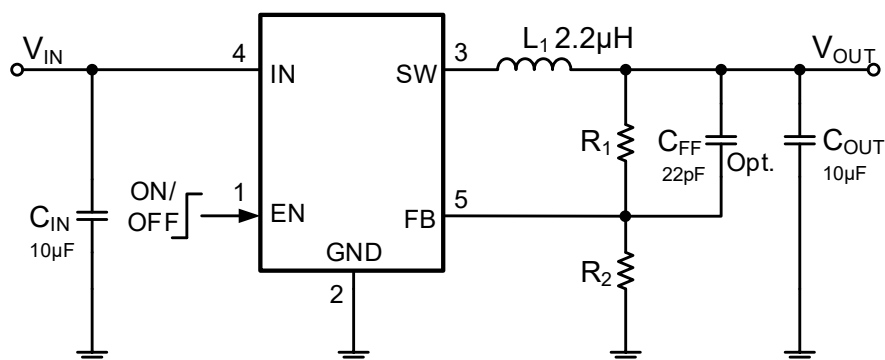

Pin Distribution

SOT-23-5

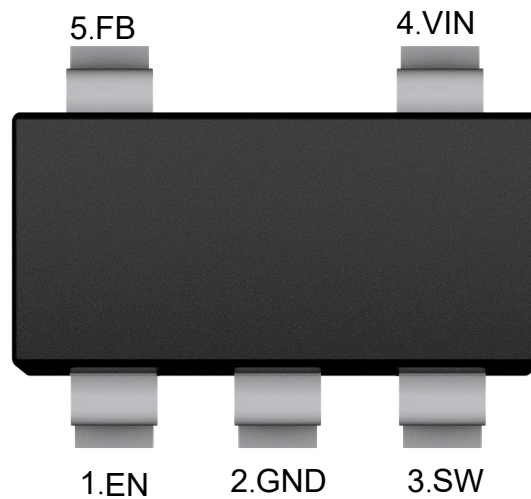

Pin Function

Pin	Name	Description
1	EN	Chip Enable Pin. Drive EN above 1.5V to turn on the part. Drive EN below 0.3V to turn it off. Do not leave EN floating.
2	GND	Ground Pin
3	SW	Power Switch Output. It is the switch node connection to Inductor. This pin connects to the drains of the internal P-ch and N-ch MOSFET switches.
4	VIN	Power Supply Input. Must be closely decoupled to GND with a 10 μ F or greater ceramic capacitor.
5	FB	Output Voltage Feedback Pin. An internal resistive divider divides the output voltage down for comparison to the internal reference voltage.

Absolute Maximum Ratings

Ratings at 25°C ambient temperature unless otherwise specified.

Characteristics	Rating	Unit
Input Supply Voltage	-0.3 ~ 7	V
EN, FB Voltages	-0.3 ~ 7	V
SW Voltage	-0.3 ~ $V_{IN}+0.3V$	V
Peak SW Sink and Source Current	1.5	A
Operating Temperature Range	-40 ~ 85	°C
Storage Temperature Range	-65 ~ 150	°C
Junction Temperature ^{Note1}	125	°C
Lead Temperature(Soldering, 10s)	300	°C
Junction to case thermal resistance	130	°C

Note: 1.The device is not guaranteed to function outside of its operating conditions.

ESD Ratings

Parameter	Symbol	Value	Unit
Human Body Model (HBM) ANSI/ESDA/JEDEC JS-001-2014 Classification, Class: 2	$V_{(ESD-HBM)}$	±2000	V
Charged Device Mode (CDM) ANSI/ESDA/JEDEC JS-002-2014 Classification, Class: C _{0b}	$V_{(ESD-CDM)}$	±200	V
JEDEC STANDARD NO.78E APRIL 2016 Temperature Classification, Class: I	$I_{LATCH-UP}$	±150	mA

Functional Block Diagram

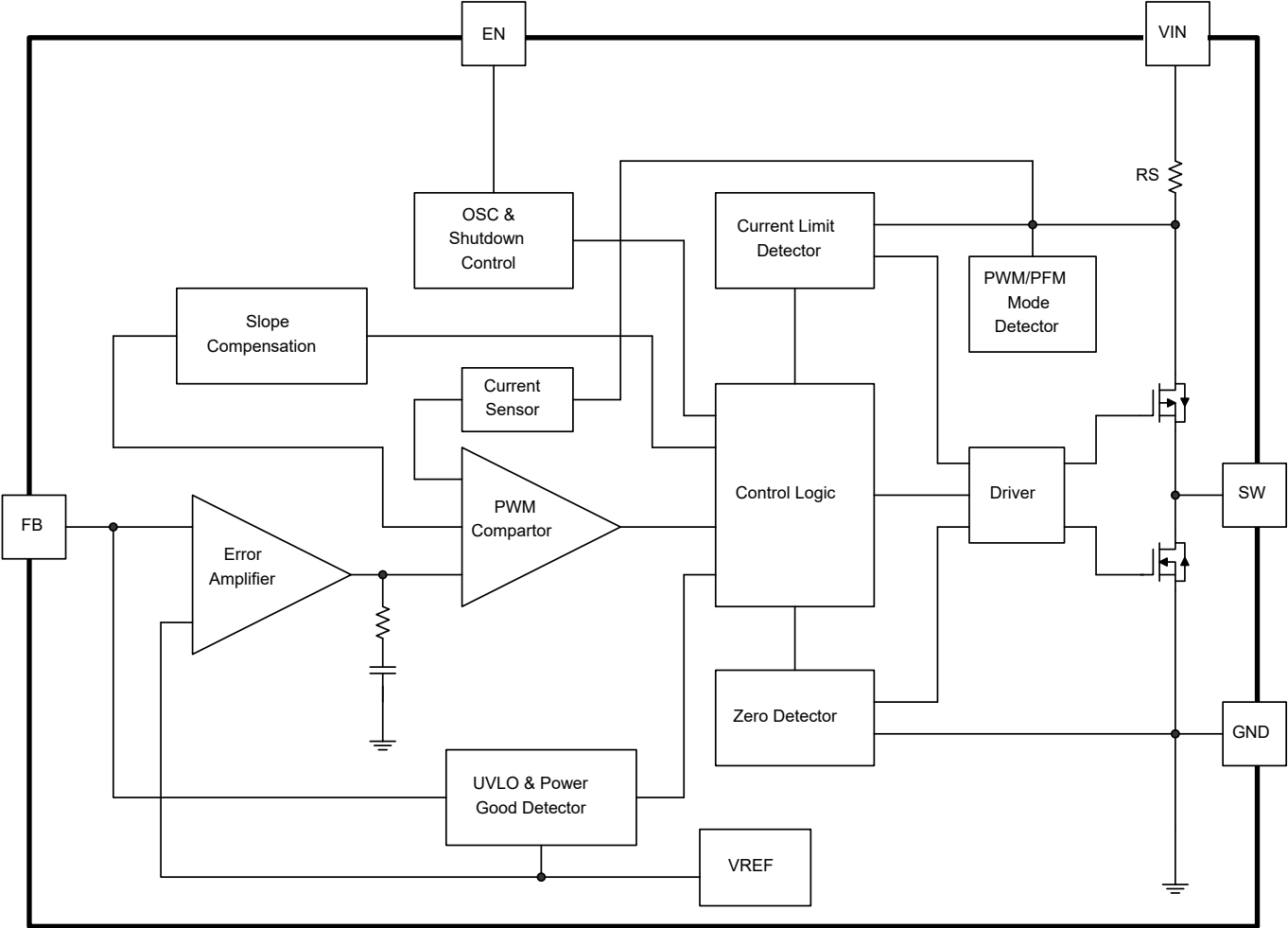

Electrical Characteristics

 ($V_{IN}=V_{EN}=3.6V$, $T_A=25^{\circ}C$, unless otherwise noted.)

Parameter	Symbol	Test Conditions	Min.	Typ.	Max.	Unit
Input Voltage Range	V_{IN}		2.7	--	5.5	V
UVLO Threshold	V_{UVLO}		--	2.5	--	V
Input DC Supply Current	I_{Supply}	FB=90%, $I_O=0mA$	--	150	300	μA
		FB=105%, $I_O=0mA$	--	40	70	
		$V_{EN}=0V$, $V_{IN}=4.2V$	--	0.1	1.0	
Regulated Feedback Voltage	V_{FB}		0.591	0.600	0.609	V
Reference Voltage Line Regulation	$\Delta V_{LINE(R)}$	$V_{IN}=2.7V$ to $5.5V$	--	0.04	0.4	%/V
Output Voltage Line Regulation	ΔV_{LINE}	$V_{IN}=2.7V$ to $5.5V$	--	0.04	0.4	%
Output Voltage Load Regulation	ΔV_{LOAD}		--	0.5	--	%
Oscillation Frequency	F_O		--	1.5	--	MHz
On Resistance of PMOS	R_{DSON_P}	$I_{SW}=100mA$	--	0.15	--	Ω
On Resistance of NMOS	R_{DSON_N}	$I_{SW}=-100mA$	--	0.13	--	Ω
Peak Current Limit	I_{LIM}	$V_{IN}=3.6V$, FB=90%	1.5	--	--	A
EN Threshold	V_{EN}		0.3	1.0	1.5	V
EN Leakage Current	I_{EN}		--	± 0.01	± 1.0	μA
SW Leakage Current	I_{SW}	$V_{EN}=0V$, $V_{IN}=V_{SW}=5V$	--	± 0.01	± 1.0	μA
Soft Start	--		--	--	1.0	mS
Thermal Shutdown Temperature	T_{SD}		--	160	--	$^{\circ}C$
Thermal Shutdown Hysteresis	T_{SDHY}		--	20	--	$^{\circ}C$

Operation

The SL6106SE uses a constant frequency, current mode step-down architecture. Both the main (P-channel MOSFET) and synchronous (N-channel MOSFET) switches are internal. During normal operation, the internal top power MOSFET is turned on each cycle when the oscillator sets the RS latch, and turned off when the current comparator, ICOMP, resets the RS latch. The peak inductor current at which ICOMP resets the RS latch, is controlled by the output of error amplifier EA. When the load current increases, it causes a slight decrease in the feedback voltage, FB, relative to the 0.6V reference, which in turn, causes the EA amplifier's output voltage to increase until the average inductor current matches the new load current. While the top MOSFET is off, the bottom MOSFET is turned on until either the inductor current starts to reverse, as indicated by the current reversal comparator IRCMP, or the beginning of the next clock cycle.

Applications Information

Setting the Output Voltage

SL6106SE require an input capacitor, an output capacitor and an inductor. These components are critical to the performance of the device. SL6106SE are internally compensated and do not require external components to achieve stable operation. The output voltage can be programmed by resistor divider.

$$V_{OUT} = V_{FB} \times \frac{R1 + R2}{R2}$$

V _{OUT}	R1	R2
1.05V	7.5KΩ	10KΩ
1.2V	10KΩ	10KΩ
1.5V	15KΩ	10KΩ
3.3V	45KΩ	10KΩ

Selecting the Inductor

The recommended inductor values are shown in the Application Circuit. It is important to guarantee the inductor core does not saturate during any foreseeable operational situation. The inductor should be rated to handle the peak load current plus the ripple current: Care should be taken when reviewing the different saturation current ratings that are specified by different manufacturers.

Saturation current ratings are typically specified at 25°C, so ratings at maximum ambient temperature of the application should be requested from the manufacturer.

$$L = \frac{V_{OUT} \times (V_{IN} - V_{OUT})}{V_{IN} \times \Delta I_L \times F_{OSC}}$$

Where ΔI_L is the inductor ripple current. Choose inductor ripple current to be approximately 30% if the maximum load current. The maximum inductor peak current is:

$$I_{L(MAX)} = I_{LOAD} + \frac{\Delta I_L}{2}$$

Under light load conditions below 100mA, larger inductance is recommended for improved efficiency.

Selecting the Output Capacitor

Special attention should be paid when selecting these components. The DC bias of these capacitors can result in a capacitance value that falls below the minimum value given in the recommended capacitor specifications table. The ceramic capacitor's actual capacitance can vary with temperature. The capacitor type X7R, which operates over a temperature range of -55°C to $+125^{\circ}\text{C}$, will only vary the capacitance to within $\pm 15\%$. The capacitor type X5R has a similar tolerance over a reduced temperature range of -55°C to $+85^{\circ}\text{C}$. Many large value ceramic capacitors, larger than 1 μF are manufactured with Z5U or Y5V temperature characteristics. Their capacitance can drop by more than 50% as the temperature varies from 25°C to 85°C . Therefore X5R or X7R is recommended over Z5U and Y5V in applications where the ambient temperature will change significantly above or below 25°C .

Tantalum capacitors are less desirable than ceramic for use as output capacitors because they are more expensive when comparing equivalent capacitance and voltage ratings in the 0.47 μF to 44 μF range. Another important consideration is that tantalum capacitors have higher ESR values than equivalent size ceramics. This means that while it may be possible to find a tantalum capacitor with an ESR value within the stable range, it would have to be larger in capacitance (which means bigger and more costly) than a ceramic capacitor with the same ESR value. It should also be noted that the ESR of a typical tantalum will increase about 2:1 as the temperature goes from 25°C down to -40°C , so some guard band must be allowed.

PC Board Layout Consideration

PCB layout is very important to achieve stable operation. It is highly recommended to duplicate EVB layout for optimum performance. If change is necessary, please follow these guidelines for reference.

1. Keep the path of switching current short and minimize the loop area formed by Input capacitor, high-side MOSFET and low-side MOSFET.
2. Bypass ceramic capacitors are suggested to be put close to the Vin Pin
3. Ensure all feedback connections are short and direct. Place the feedback resistors and compensation components as close to the chip as possible.
4. VOUT, SW away from sensitive analog areas such as FB.
Connect IN, SW, and especially GND respectively to a large copper area to cool the chip to improve thermal performance and long-term reliability

Package Outline

SOT-23-5

Dimensions in mm

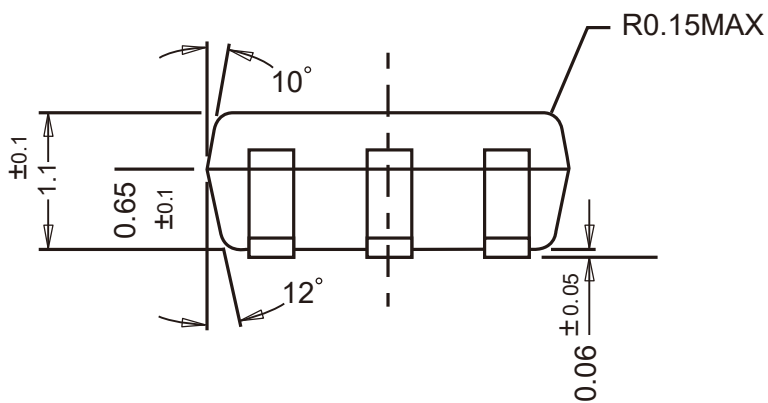
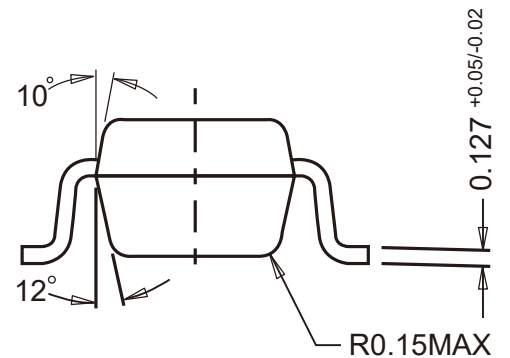
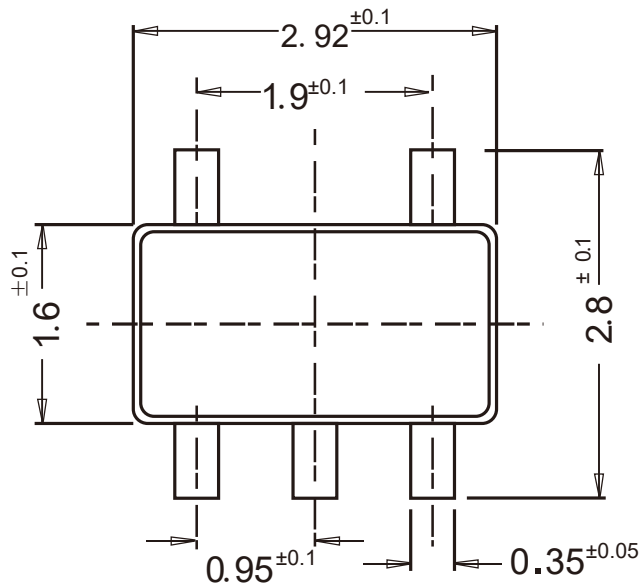

Ordering Information

Device	Package	Shipping
SL6106SE	SOT-23-5	3,000PCS/Reel&7inches