

PJA300F

① PJ ② A ③ 300 ④ F ⑤ -□

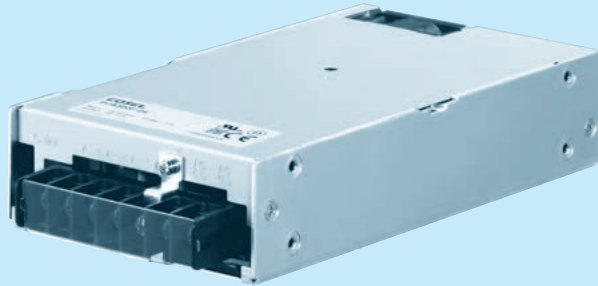

Example recommended EMI/EMC filter
NAC-06-472



High voltage pulse noise type : NAP series
Low leakage current type : NAM series
* A higher current rating EMI/EMC filter may be recommended in view of the other devices that could be connected in parallel with the power supply.

- ① Series name
- ② Single output
- ③ Output wattage
- ④ Universal input
- ⑤ Output voltage

*Make sure necessary tests will be carried out on your end equipment with the power supply installed in accordance with any required EMC/EML regulations.

SPECIFICATIONS

MODEL		PJA300F-5	PJA300F-12	PJA300F-15	PJA300F-24	PJA300F-36	PJA300F-48	
INPUT	VOLTAGE[V]	AC85 - 264 1 φ (Output derating is required at AC85V - 100V. See 1.1 and 3.2 in Instruction Manual)						
	CURRENT[A]	ACIN 100V	3.5typ (Io=100%)	3.9typ (Io=100%)				
		ACIN 115V	3.0typ (Io=100%)	3.3typ (Io=100%)				
		ACIN 230V	1.5typ (Io=100%)	1.7typ (Io=100%)				
	FREQUENCY[Hz]	50 / 60 (47 - 63)						
	EFFICIENCY[%]	ACIN 100V	73typ (Io=100%)	79typ (Io=100%)	81typ (Io=100%)	82typ (Io=100%)	83typ (Io=100%)	82typ (Io=100%)
		ACIN 115V	74typ (Io=100%)	80typ (Io=100%)	82typ (Io=100%)	83typ (Io=100%)	83typ (Io=100%)	83typ (Io=100%)
		ACIN 230V	77typ (Io=100%)	82typ (Io=100%)	84typ (Io=100%)	86typ (Io=100%)	87typ (Io=100%)	86typ (Io=100%)
	POWER FACTOR	ACIN 100V	0.99typ (Io=100%)					
		ACIN 115V	0.98typ (Io=100%)					
ACIN 230V		0.95typ (Io=100%)						
INRUSH CURRENT[A]	ACIN 100V	20typ (Io=100%) Ta=25°C at cold start						
	ACIN 115V	20typ (Io=100%) Ta=25°C at cold start						
	ACIN 230V	40typ (Io=100%) Ta=25°C at cold start						
LEAKAGE CURRENT[ma]	0.75max (ACIN 240V, 60Hz, Io=100%, According to IEC62368-1 and DEN-AN)							
OUTPUT	VOLTAGE[V]	5	12	15	24	36	48	
	CURRENT[A]	ACIN 85-100V	Output derating is required at ACIN 100V or less (refer to instruction manual 3.2)					
		ACIN 100V-264V	50	25	20	12.5	8.4	6.3
	WATTAGE[W]	ACIN 85-100V	Output derating is required at ACIN 100V or less (refer to instruction manual 3.2)					
		ACIN 100V-264V	250	300	300	300	302.4	302.4
	LINE REGULATION[mV]	*5	20max	48max	60max	96max	144max	192max
	LOAD REGULATION[mV]	*5	40max	100max	120max	150max	150max	300max
	RIPPLE[mVp-p]	0 to +50°C	80max	120max	120max	120max	150max	150max
		*1 -10 to 0°C	140max	160max	160max	160max	160max	400max
	RIPPLE NOISE[mVp-p]	0 to +50°C	120max	150max	150max	150max	200max	200max
		*1 -10 to 0°C	160max	180max	180max	180max	240max	500max
	TEMPERATURE REGULATION[mV]	0 to +50°C	50max	120max	150max	240max	360max	480max
		*2 -10 to +50°C	75max	180max	180max	290max	440max	600max
	DRIFT[mV]	*2	20max	48max	60max	96max	144max	192max
	START-UP TIME[ms]		300typ (ACIN 100V, Io=100%)					
HOLD-UP TIME[ms]		20typ (ACIN 100V, Io=100%)						
OUTPUT VOLTAGE ADJUSTMENT RANGE[V]		4.50 to 5.50	10.80 to 13.20	13.50 to 16.50	21.60 to 26.40	32.40 to 39.60	43.20 to 52.80	
OUTPUT VOLTAGE SETTING[V]		5.00 to 5.15	12.00 to 12.48	15.00 to 15.60	24.00 to 24.96	36.00 to 37.44	48.00 to 49.92	
PROTECTION CIRCUIT AND OTHERS	OVERCURRENT PROTECTION	Works over 105% of rating and recovers automatically						
	OVERVOLTAGE PROTECTION[V]	5.75 to 7.00	13.80 to 16.80	17.25 to 21.00	27.60 to 33.60	41.40 to 50.40	55.20 to 67.20	
	OPERATING INDICATION	LED (Green)						
	REMOTE SENSING	Not provided						
ISOLATION	INPUT-OUTPUT	AC3,000V 1minute, Cutoff current = 10mA, DC500V 50MΩ min (At room temperature)						
	INPUT-FG	AC2,000V 1minute, Cutoff current = 10mA, DC500V 50MΩ min (At room temperature)						
	OUTPUT-FG	AC500V 1minute, Cutoff current = 100mA, DC500V 50MΩ min (At room temperature)						
ENVIRONMENT	OPERATING TEMP., HUMID. AND ALTITUDE *3	-20 to +70°C (Output derating is required), 20 - 90%RH (Non condensing), 3,000m (10,000 feet) max						
	STORAGE TEMP., HUMID. AND ALTITUDE	-20 to +75°C, 20 - 90%RH (Non condensing), 9,000m (30,000 feet) max						
	VIBRATION	10 - 55Hz, 19.6m/s ² (2G), 3minutes period, 60minutes each along X, Y and Z axes						
	IMPACT	196.1m/s ² (20G), 11ms, once each X, Y and Z axes						
SAFETY AND NOISE REGULATIONS	AGENCY APPROVALS	UL62368-1, C-UL (CSA62368-1), EN62368-1 Complies with DEN-AN						
	CONDUCTED NOISE	Complies with FCC-B, VCCI-B, CISPR22-B, EN55011-B, EN55022-B						
	HARMONIC ATTENUATOR *7	Complies with IEC61000-3-2 class A						

SPECIFICATIONS

OTHERS	CASE SIZE/WEIGHT	102 X 41 X 190mm [4.02 X 1.61 X 7.48 inches] (Excluding terminal block and screw) (W X H X D) / 1.0kg max
	COOLING METHOD	*7 Forced cooling (internal fan)
WARRANTY	WARRANTY	*5 5 years (subject to the operating conditions)

- *1 This is the result of measurement of the testing board with capacitors of 22 μF and 0.1 μF placed at 150 mm from the output terminals by a 20 MHz oscilloscope or a ripple-noise meter equivalent to Keisoku-Giken RM103.
See 1.6 of Instruction Manual for more details.
- *2 Drift is the change in DC output for an eight hour period after a half-hour warm-up at 25°C.
- *3 Output power derating is required. See 3.2 in Instruction Manual.
- *4 See 3.3 in Instruction Manual for more details.
- *5 Consult us about dynamic load and input response.
- *6 The fan speed slows down at no load.
- *7 Consult us about other classes.
- * Do not use the power supply in overcurrent conditions or in unspecified input voltage ranges. Otherwise the internal components may be damaged.
- * Parallel operation is not possible with this mode.
- * Sound noise may be heard from the power supply when used for pulse load.

Features

- Cost-effective
- Longer life (see Instruction Manual)
- Low profile (meets 1U height = 41 mm or 1.61 inches)
- Wide operating temperature range (-20°C to +70°C see instruction manual)
- Slow fan speed at no load
- Complies with SEMI F-47

Block diagram

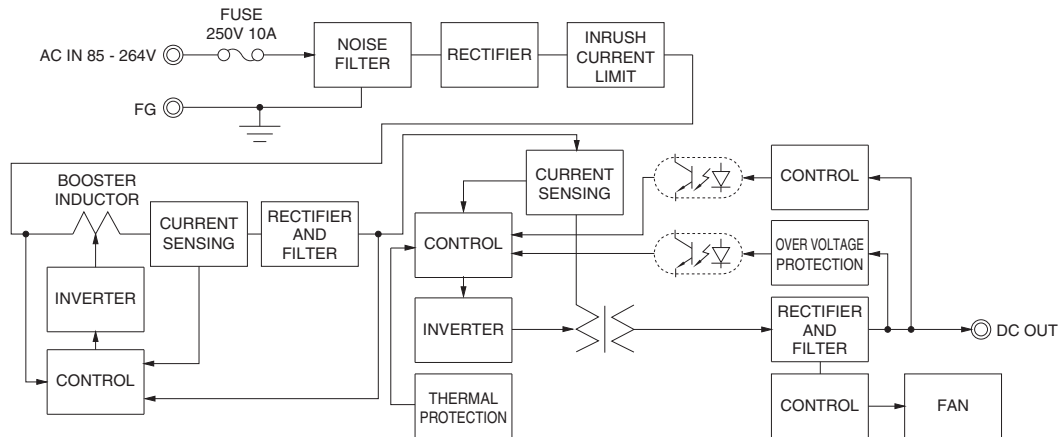

External view

