

Description

The TL432 series ICs are low voltage three-terminal adjustable regulators with guaranteed thermal stability over a full operation range. These ICs feature sharp turn-on characteristics, low temperature coefficient and low output impedance, which make them ideal substitutes for Zener diodes in applications such as switching power supply, charger, motherboard and other adjustable regulators.

The output voltage can be set to any value between 1.25V and 18V with two external resistors.

The TL432 precision reference is offered in two voltage tolerance: 0.5%.

These ICs are available in 4 packages: TO-92 (bulk or ammo packing), SOT-23, SOT-23-5 and SOT-89.

Features

- Wide Programmable Precise Output Voltage from 1.25V to 18V
- High Stability under Capacitive Load
- Low Temperature Deviation: 3mV Typical
- Low Equivalent Full-Range Temperature Coefficient : 20PPM/°C Typical
- Low Dynamic Output Resistance: 0.05Ω Typical
- High Sink Current Capacity from 0.1mA to 100mA
- Low Output Noise
- Wide Operating Range of -40 to +125°C

Applications

- Graphic Card
- PC Motherboard
- Voltage Adapter
- Switching Power
- Supply Charger

Pin Assignments

(Top View)

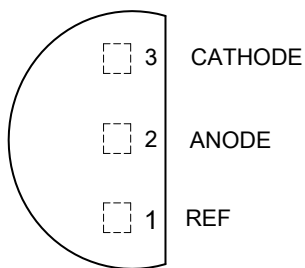

(TO-92 (Bulk Packing)/ Z Package)

(Top View)

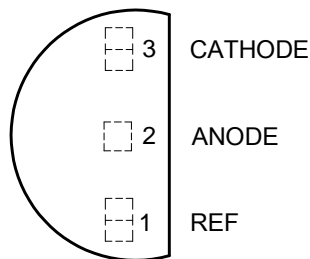

(TO-92 (Ammo Packing)/ Z Package)

(Top View)

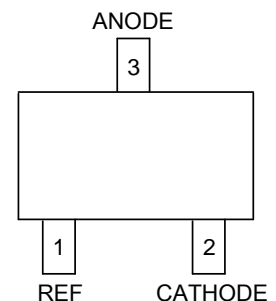

(SOT-23/ N Package)

Pin Assignments (Cont.)

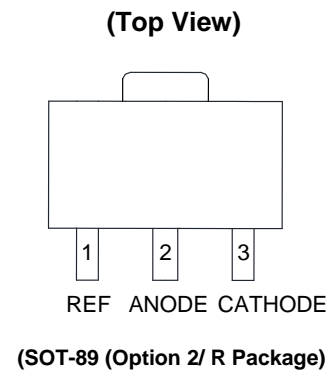
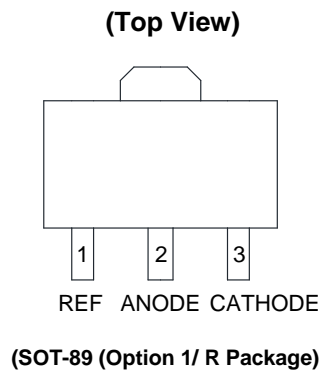
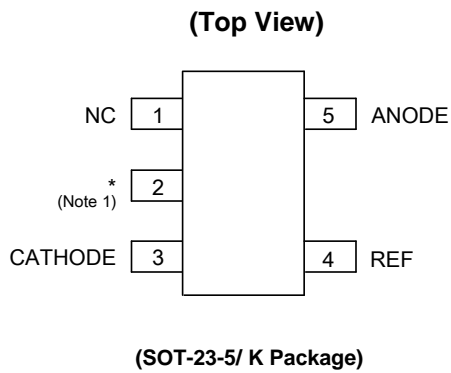

Note 1: *Pin 2 is attached to substrate and must be connected to ANODE or open.

Typical Applications Circuit

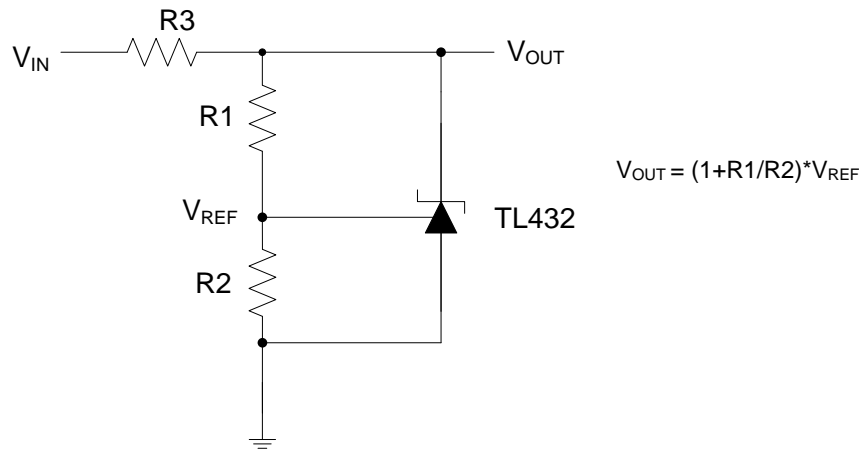

Shunt Regulator

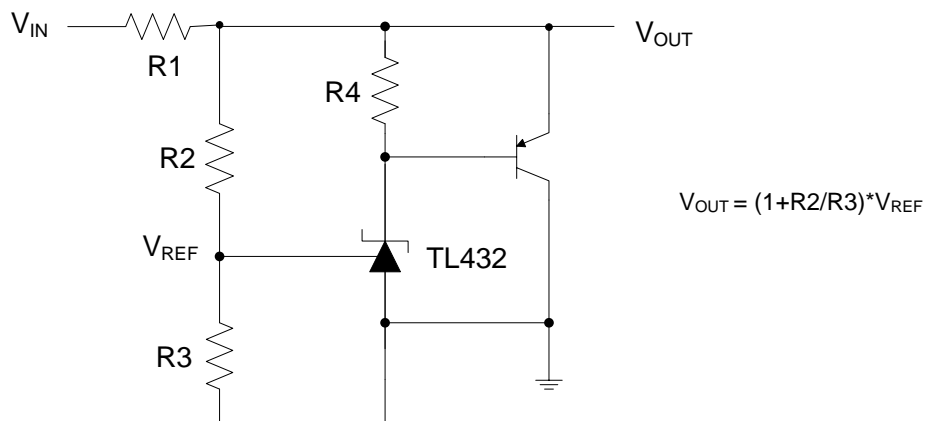

High Current Shunt Regulator

Typical Applications Circuit (Cont.)

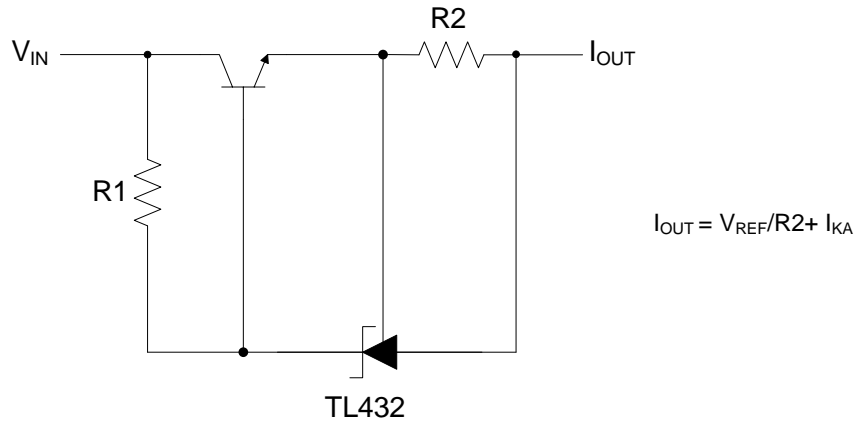

Current Source or Current Limit

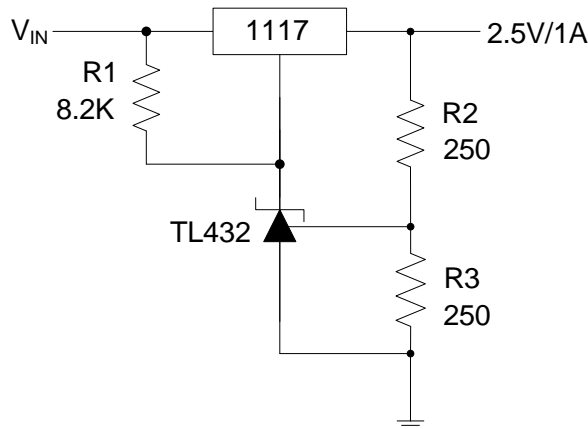

Precision 2.5V/1A Regulator

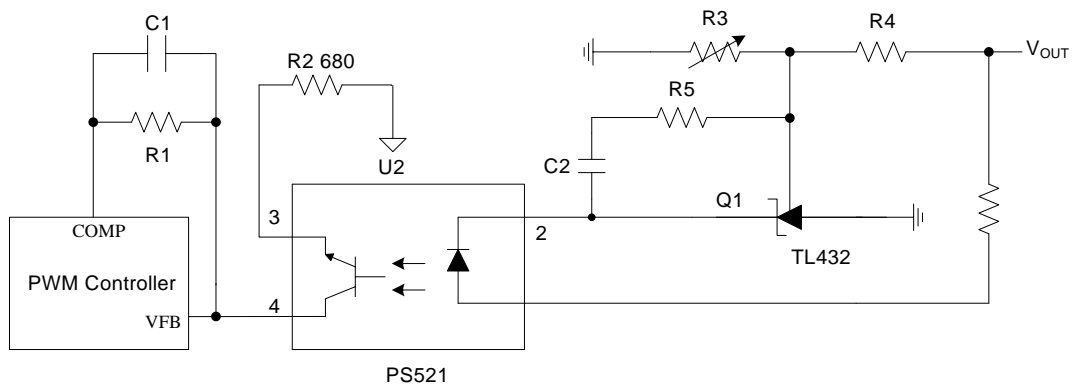

PWM Converter with Reference

Functional Block Diagram

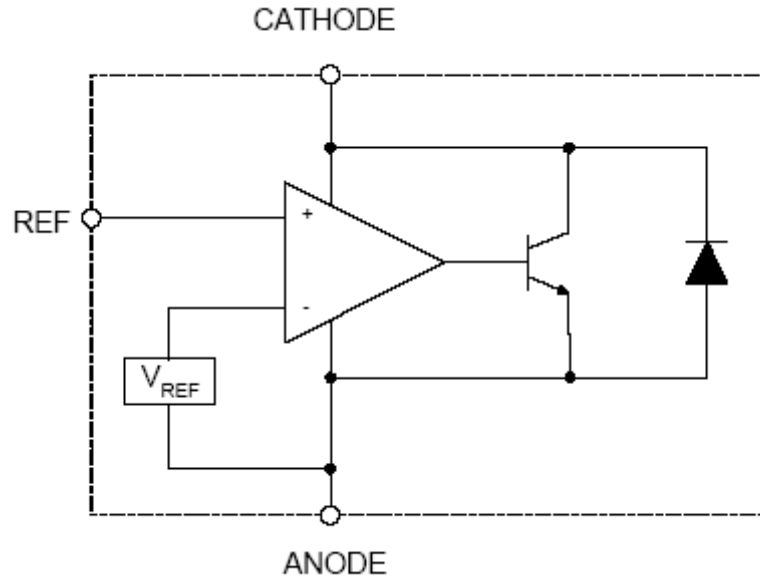

Absolute Maximum Ratings (Note 2)

Symbol	Parameter	Rating	Unit
V_{KA}	Cathode Voltage	20	V
I_{KA}	Cathode Current Range (Continuous)	-100 to 100	mA
I_{REF}	Reference Input Current Range	10	mA
P_D	Power Dissipation	Z, R Package	770
		N, K Package	370
T_J	Junction Temperature	+150	°C
T_{STG}	Storage Temperature Range	-65 to +150	°C

Note 2: Stresses greater than those listed under “Absolute Maximum Ratings” may cause permanent damage to the device. These are stress ratings only, and functional operation of the device at these or any other conditions beyond those indicated under “Recommended Operating Conditions” is not implied. Exposure to “Absolute Maximum Ratings” for extended periods may affect device reliability.

Recommended Operating Conditions

Symbol	Parameter	Min	Max	Unit
V_{KA}	Cathode Voltage	V_{REF}	18	V
I_{KA}	Cathode Current	0.1	100	mA
–	Operating Ambient Temperature Range	-40	+125	°C

Electrical Characteristics (Typical and limits apply for $T_A = +25^\circ\text{C}$, unless otherwise noted.)

Symbol	Parameter	Test Circuit	Conditions	Min	Typ	Max	Unit	
V_{REF}	Reference Voltage	4	$V_{KA} = V_{REF}, I_{KA} = 10\text{mA}$	0.5%	1.244	1.250	1.256	V
				1.0%	1.238	1.250	1.262	
ΔV_{REF}	Deviation of Reference Voltage Over Full Temperature Range	4	$V_{KA} = V_{REF}, I_{KA} = 10\text{mA}$	0 to $+70^\circ\text{C}$	–	2	10	mV
				-40 to $+85^\circ\text{C}$	–	3	10	
				-40 to $+125^\circ\text{C}$	–	4	15	
$\frac{\Delta V_{REF}}{\Delta V_{KA}}$	Ratio of Change in V_{REF} to the Change in Cathode Voltage	5	$I_{KA} = 10\text{mA}, \Delta V_{KA}: V_{REF}$ to 16V	–	-0.5	-1.5	mV/V	
I_{REF}	Reference Input Current	5	$I_{KA} = 10\text{mA}, R1 = 10\text{K}\Omega, R2 = \infty$	–	0.15	0.4	μA	
ΔI_{REF}	Deviation of Reference Current Over Full Temperature Range	5	$I_{KA} = 10\text{mA}, R1 = 10\text{K}\Omega, R2 = \infty, T_A = -40$ to $+125^\circ\text{C}$	–	0.1	0.4	μA	
I_{KA} (Min)	Minimum Cathode Current for Regulation	4	$V_{KA} = V_{REF}$	–	55	80	μA	
I_{KA} (Off)	Off-state Cathode Current	6	$V_{REF} = 0, V_{KA} = 18\text{V}$	–	0.04	0.10	μA	
			$V_{KA} = 6\text{V}, V_{REF} = 0$	–	0.01	0.05		
Z_{KA}	Dynamic Impedance	4	$V_{KA} = V_{REF}, I_{KA} = 1$ to $100\text{mA}, f \leq 1.0\text{KHz}$	–	0.05	0.15	Ω	
θ_{JC}	Thermal Resistance (Junction to Case)	–	SOT-23	–	84.84	–	$^\circ\text{C/W}$	
			SOT-23-5	–	84.84	–		
			TO-92	–	140.80	–		
			SOT-89	–	29.80	–		

Electrical Characteristics (Cont.) Test Circuit 4 for $V_{KA} =$

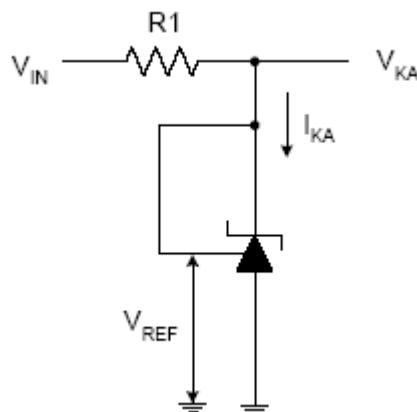

V_{REF} Test Circuit 5 for $V_{KA} >$

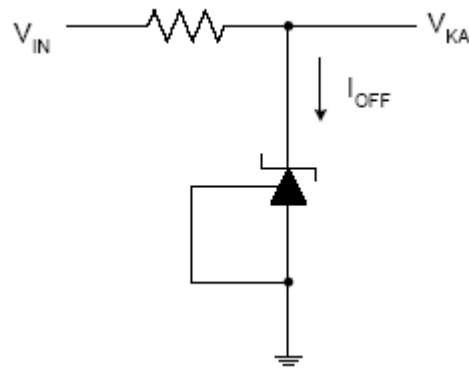
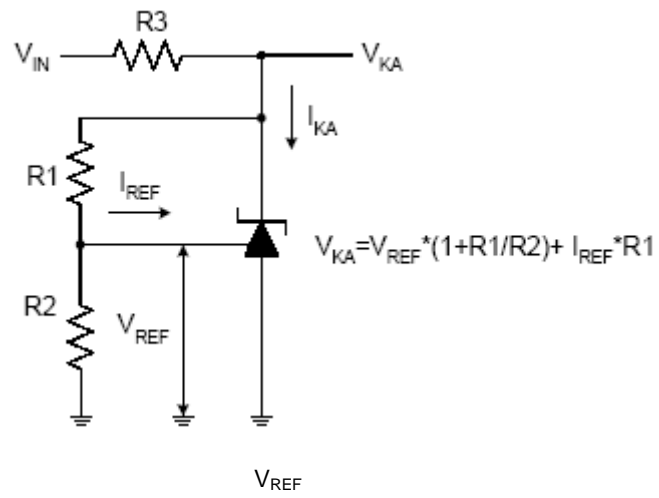

Test Circuit 6 for I_{OFF}

Performance Characteristics

Reference Voltage vs. Ambient Temperature

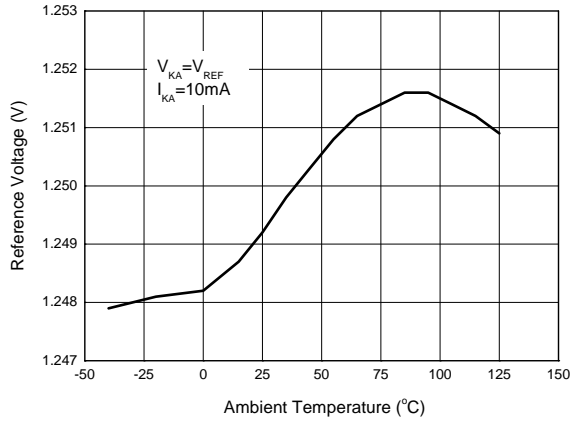

Reference Current vs. Ambient Temperature

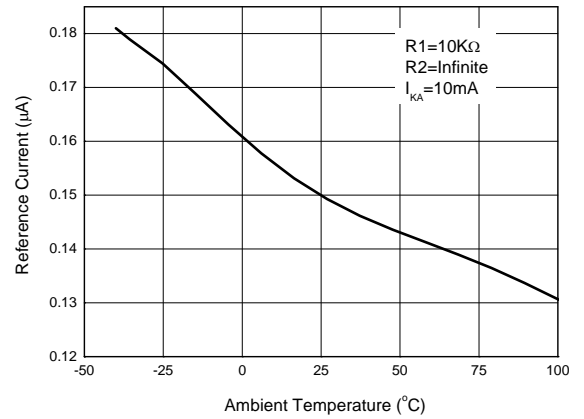

Cathode Current vs. Cathode Voltage

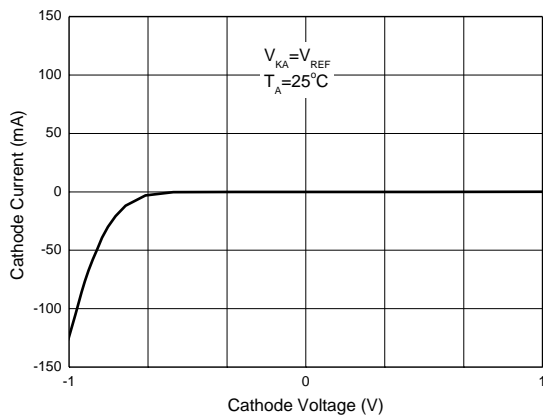

Cathode Current vs. Cathode Voltage

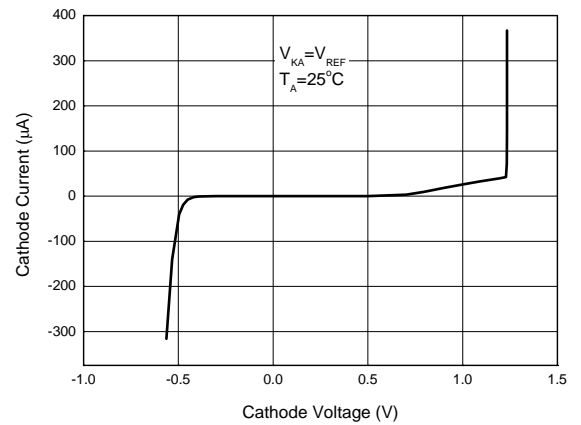

Small Signal Voltage Gain vs. Frequency

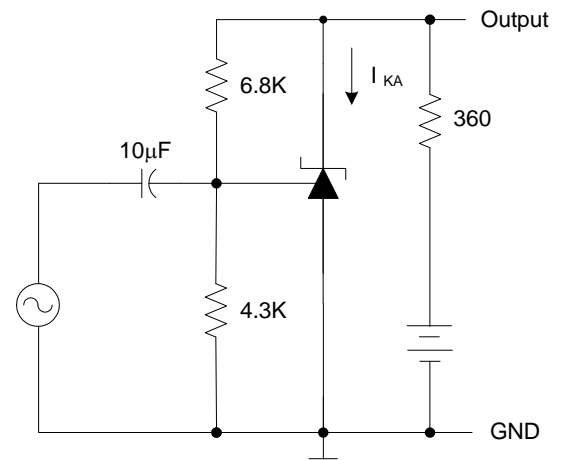
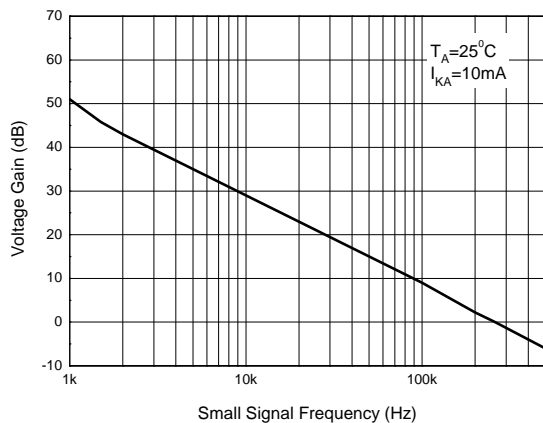

Performance Characteristics (Cont.)

Dynamic Impedance vs. Frequency

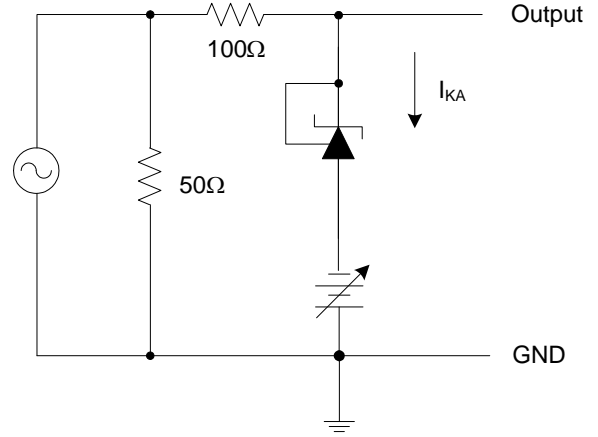
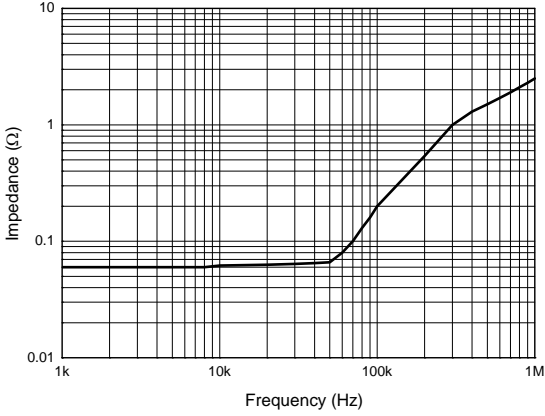

Pulse Response of Input and Output Voltage

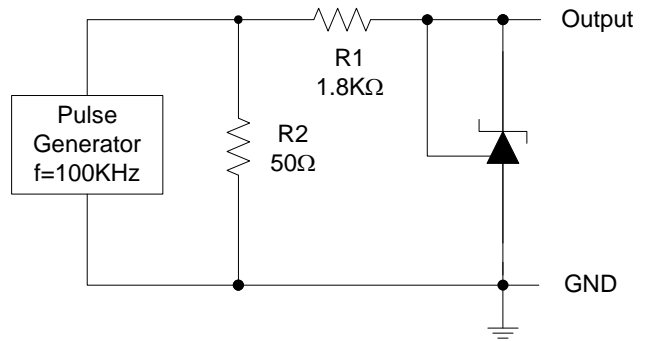
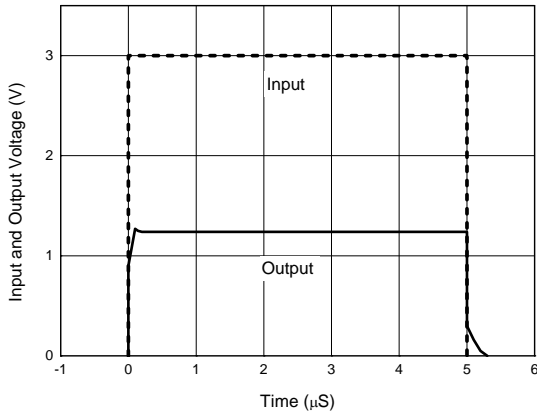

Ratio of Delta Reference Voltage to the Ratio of Delta Cathode Voltage vs. Ambient Temperature

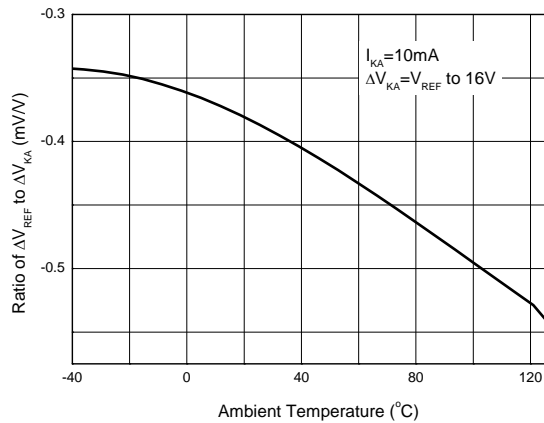

Package Outline Dimensions (All dimensions in mm(inch).)

(1) Package Type: TO-92 (Bulk Packing)

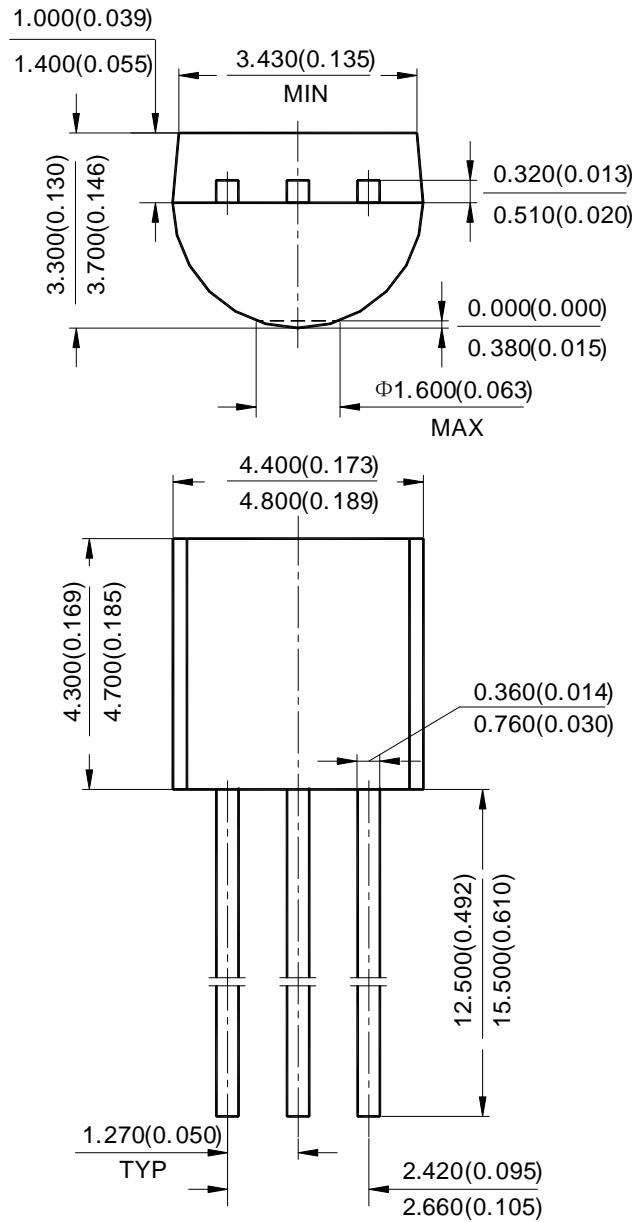

Package Outline Dimensions (Cont. All dimensions in mm(inch).)

(2) Package Type: TO-92 (Ammo Packing)

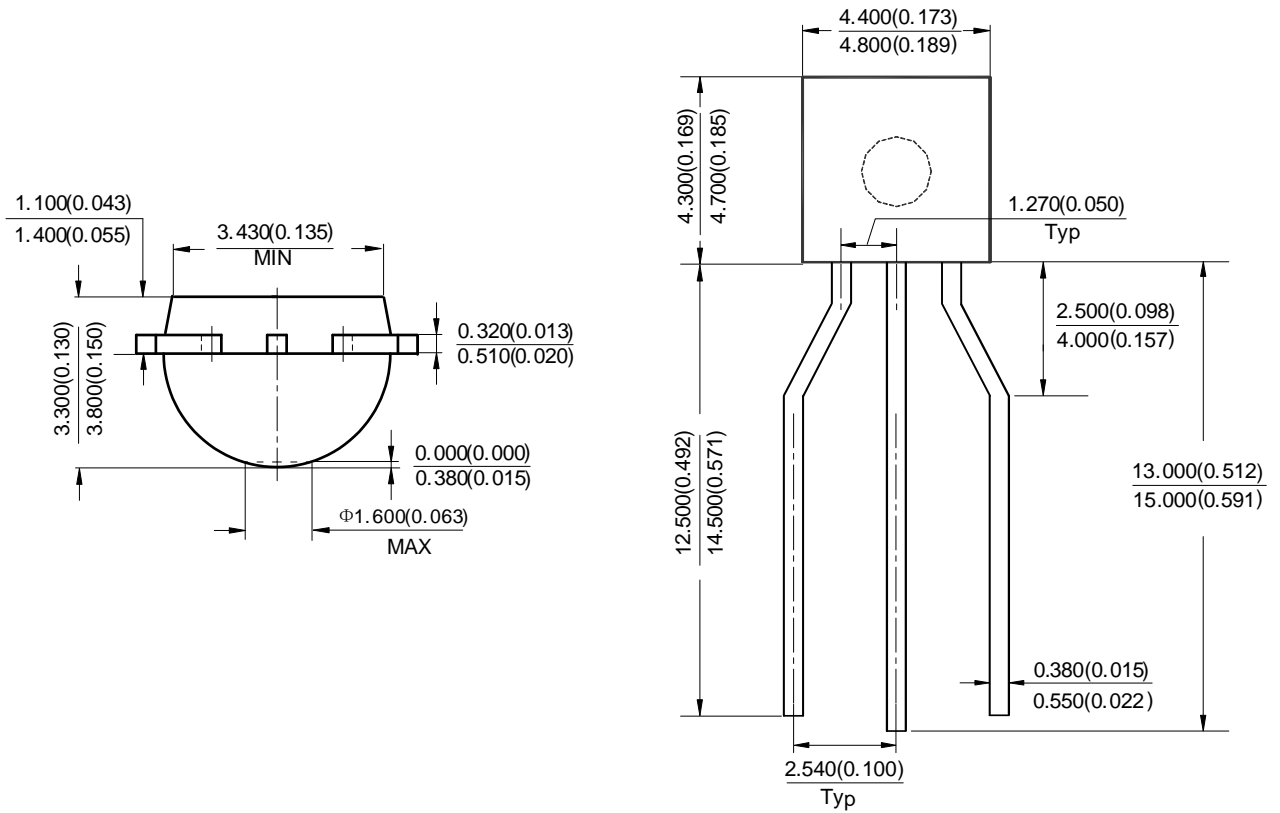

Package Outline Dimensions (Cont. All dimensions in mm(inch).)

(3) Package Type: SOT-23

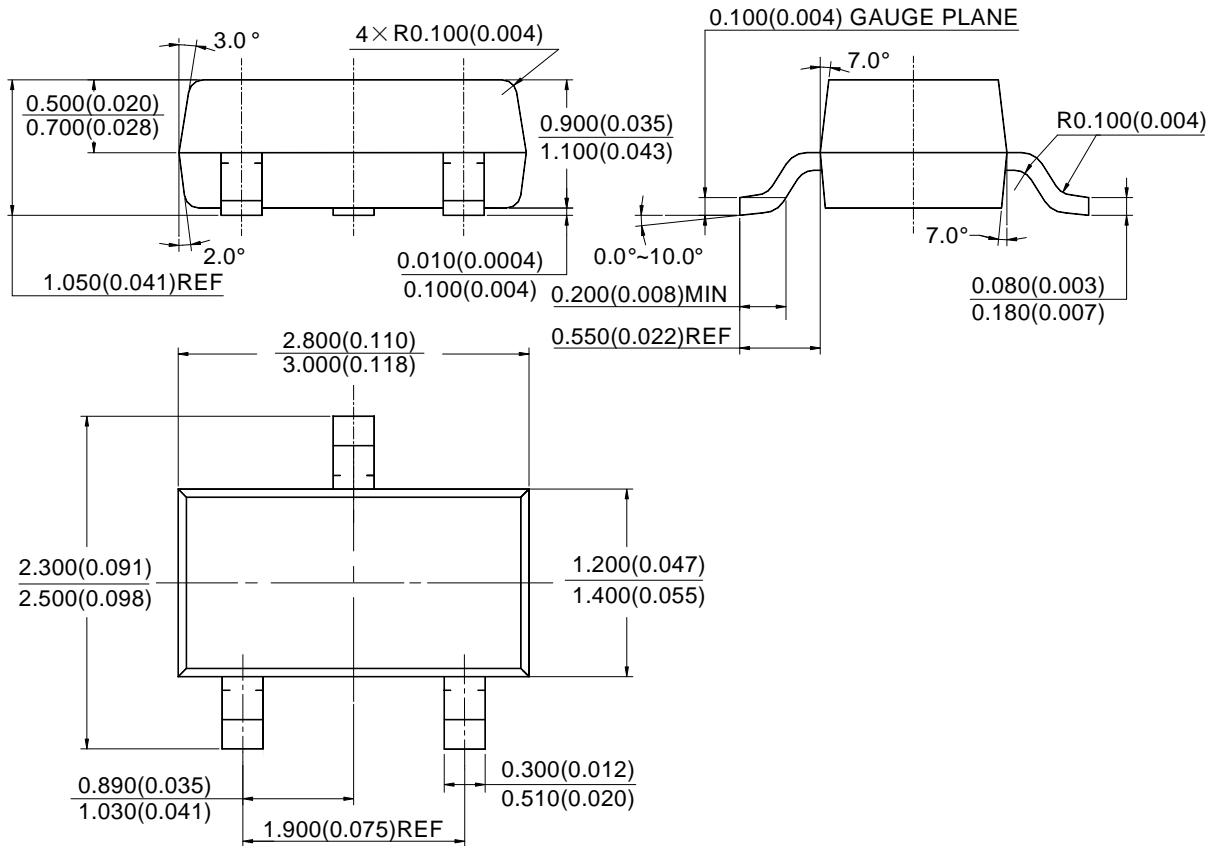

Package Outline Dimensions (Cont. All dimensions in mm(inch).)

(4) Package Type: SOT-23-5

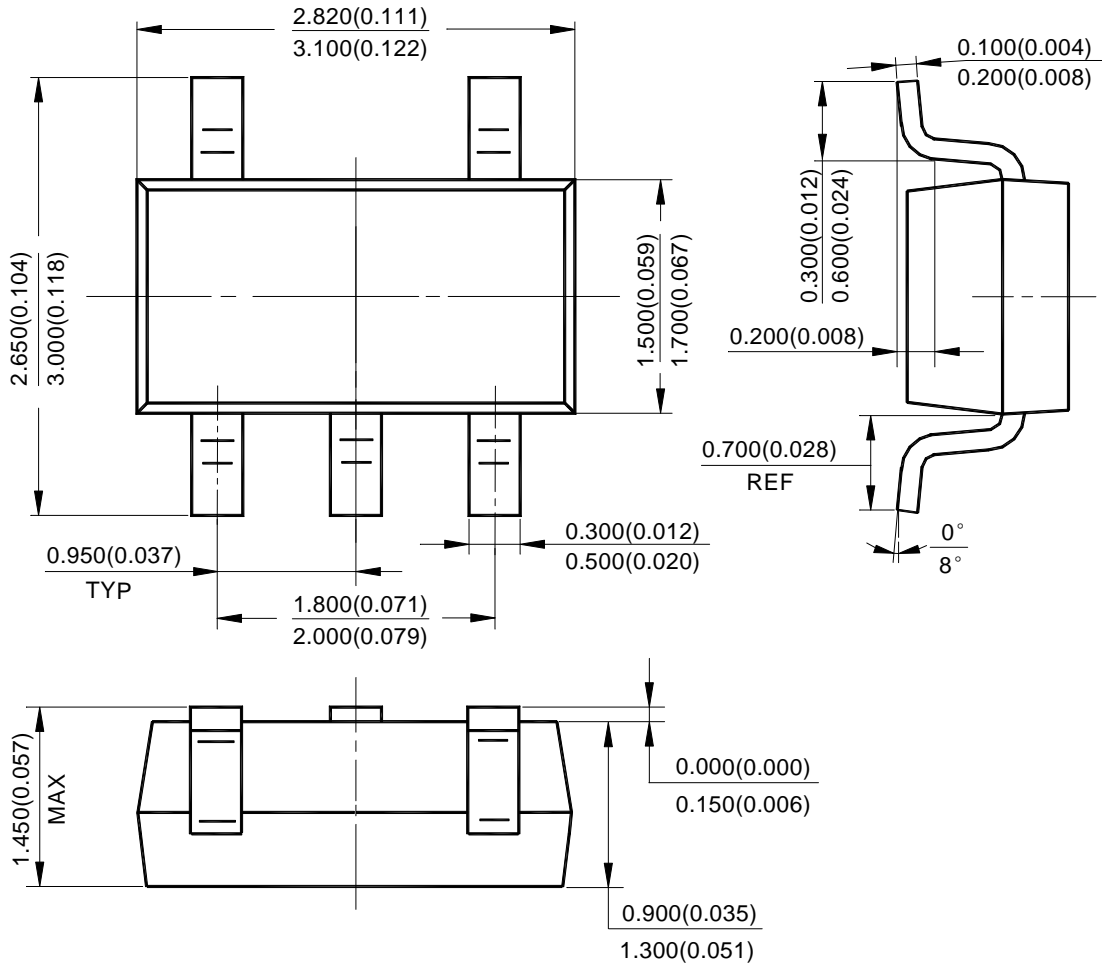

Package Outline Dimensions (Cont. All dimensions in mm(inch).)

(5) Package Type: SOT-89

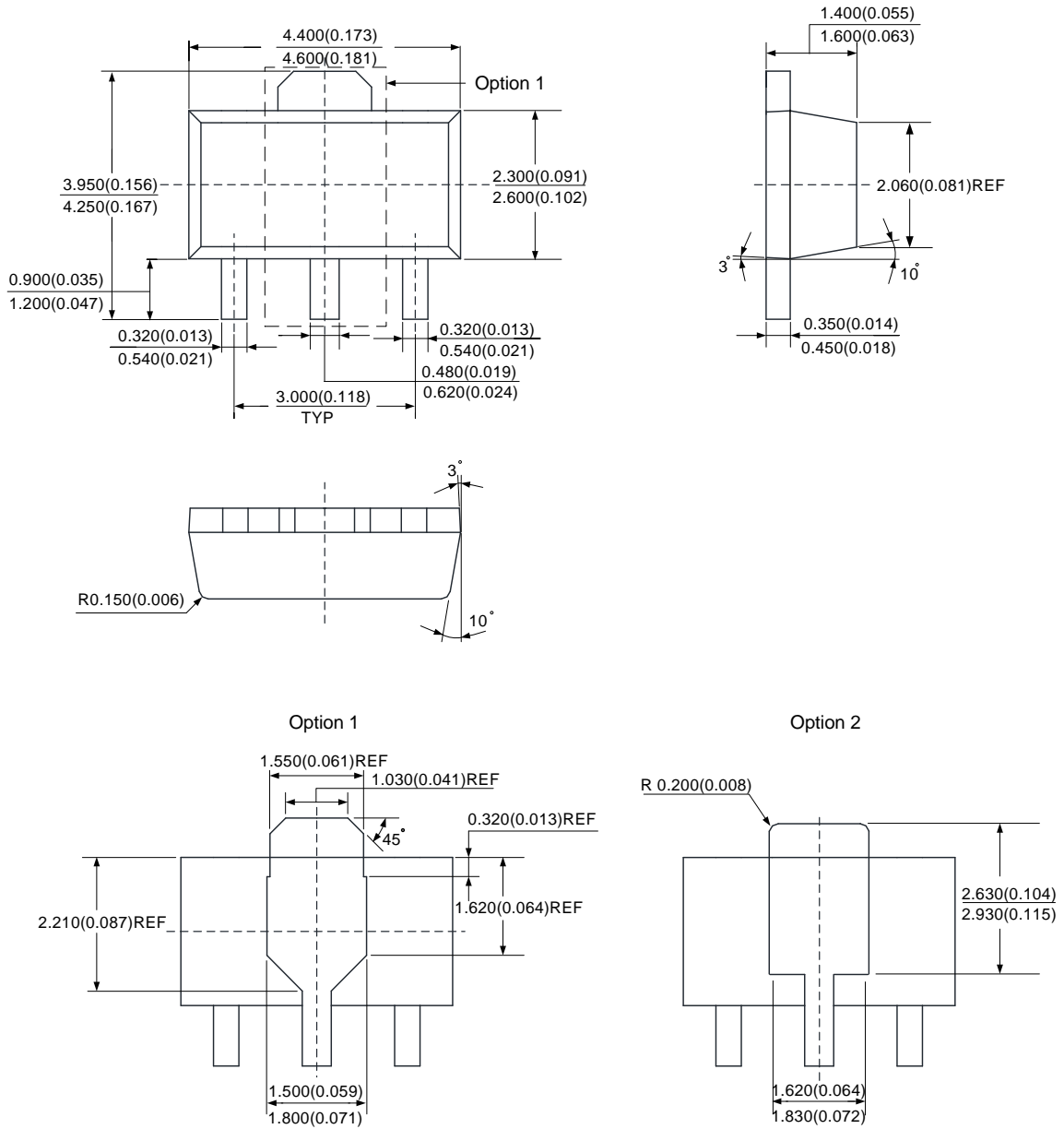

Suggested Pad Layout

(1) Package Type: SOT-23

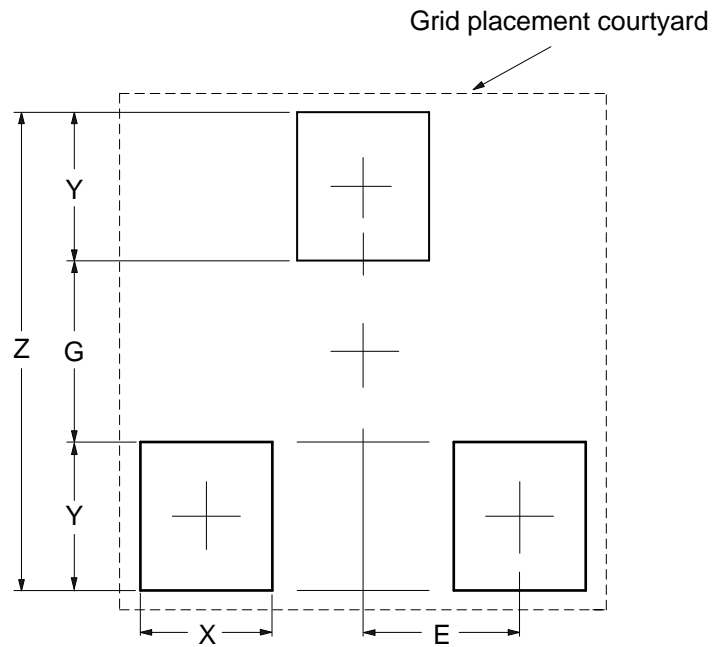

Dimensions	Z (mm)/(inch)	G (mm)/(inch)	X (mm)/(inch)	Y (mm)/(inch)	E (mm)/(inch)
Value	2.900/0.114	1.100/0.043	0.800/0.031	0.900/0.035	0.950/0.037

Suggested Pad Layout (Cont.)

(2) Package Type: SOT-23-5

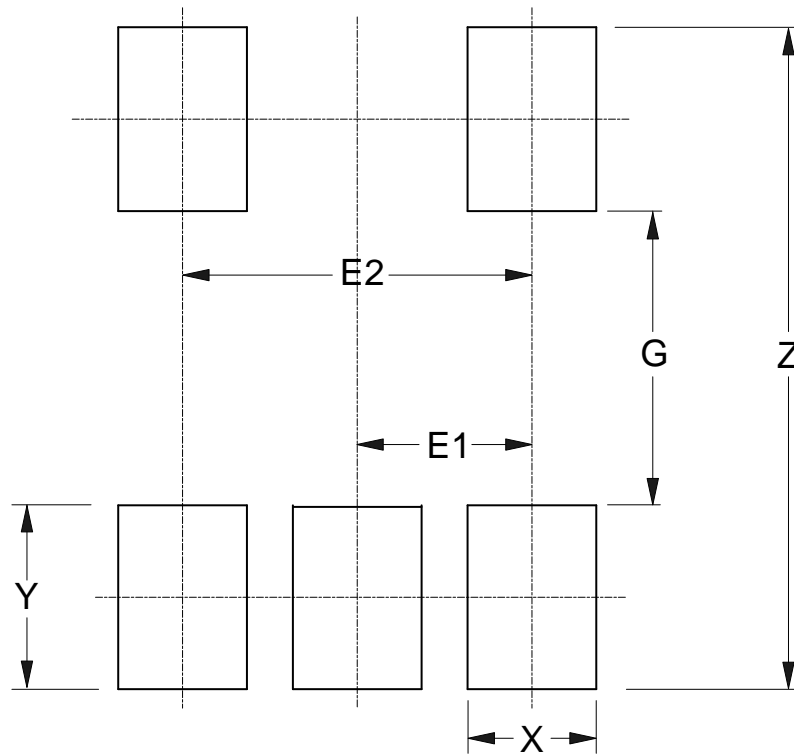

Dimensions	Z (mm)/(inch)	G (mm)/(inch)	X (mm)/(inch)	Y (mm)/(inch)	E1 (mm)/(inch)	E2 (mm)/(inch)
Value	3.600/0.142	1.600/0.063	0.700/0.028	1.000/0.039	0.950/0.037	1.900/0.075

Suggested Pad Layout (Cont.)

(3) Package Type: SOT-89

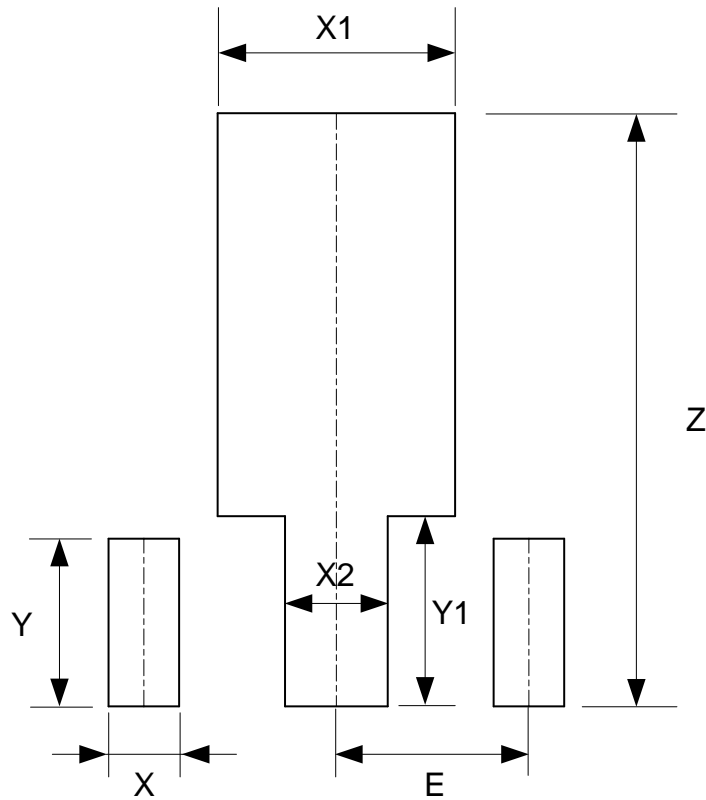

Dimensions	Z (mm)/(inch)	X (mm)/(inch)	X1 (mm)/(inch)	X2 (mm)/(inch)	Y (mm)/(inch)	Y1 (mm)/(inch)	E (mm)/(inch)
Value	4.600/0.181	0.550/0.022	1.850/0.073	0.800/0.031	1.300/0.051	1.475/0.058	1.500/0.059