

## GENERAL DESCRIPTION

The FSUSB42MUX/FSUSB42UMX is a high bandwidth , fast double-pole double-throw (DPDT) analog switch . Its wide bandwidth and low bit-to-bit skew allow it to pass highspeed differential signals with good signal integrity. Each switch is bidirectional and offers little or no attenuation of the high-speed signals at the outputs.Its high channel-to-channel crosstalk rejection results in minimal noise interference.

## FEATURES

- Supply Range: 1.8 V to 5.5 V
- Rail-to-Rail Signal Range
- On-Resistance Matching: 0.05  $\Omega$  (TYP)
- ON-Resistance Flatness: 6.5  $\Omega$  (TYP) at 3 V
- High Off Isolation: -32 dB at 250 MHz
- -41 dB (250 MHz) Crosstalk Rejection Reduces
- Break-Before-Make Switching
- -3 dB Bandwidth: 720 MHz
- Operation Temperature Range: -40°C to +85°C

## Application

- Cell Phones
- PDAs
- Portable Instrumentation
- Differential Signal Data Routings
- USB 2.0 Signal Routing

## Reference News

<p style="text-align: center;"><b>Pin Configuration</b></p> <p style="text-align: center;"><b>MSOP-10</b></p>	<p style="text-align: center;"><b>MARKING</b></p>
<p style="text-align: center;"><b>Pin Configuration</b></p> <p style="text-align: center;"><b>UFQFN-10(1.4x1.8)</b></p>	<p style="text-align: center;"><b>MARKING</b></p>

## Pin Description

Name	Pin Number		Description
	QA	MA	
V+	9	1	Positive Power Supply
S	10	2	Select Input
D+,D-	1,2	3,4	Data Ports
HSD1+,HSD1-	5,4	7,6	Data Ports 1
HSD2+,HSD2-	7,6	9,8	Data Ports 2
/OE	8	10	Output Enable
GND	3	5	Ground

## Logic Function Table

/OE	S	HSD1+,HSD1-	HSD2+,HSD2-
0	0	ON	OFF
0	1	OFF	ON
1	X	OFF	OFF

## Order information

P/N	PKG	QTY
FSUSB42MUX	MSOP-10	4000PCS
FSUSB42UMX	UFQFN-10(1.4x1.8)	4000PCS

## Circuit Diagram

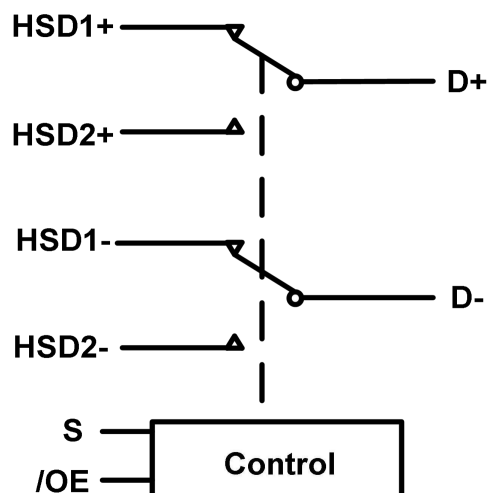

## Voltage, Temperature, ESD and Thermal Ratings

### Absolute Maximum Ratings

Parameters		Min.	Max.	Unit
V+	Supply Voltage Range	-0.3	6	V
V <sub>IS</sub>	Analog, Digital Voltage Range	-0.3	(V+)+0.3	V
I <sub>IN</sub>	Continuous Current HSDn or Dn	-100	+100	mA
I <sub>peak</sub>	Peak Current HSDn or Dn	-150	+150	mA
T <sub>J</sub>	Junction Temperature		150	°C
T <sub>stg</sub>	Storage Temperature	-65	150	°C

(1) Stresses beyond those listed under "Absolute Maximum Ratings" may cause permanent damage to the device. These are stress ratings only, and functional operation of the device at these or any other conditions beyond those indicated under "Recommended Operating Conditions" is not implied. Exposure to absolute-maximum-rated conditions for extended periods may affect device reliability.

(2) The input and output negative-voltage ratings may be exceeded if the input and output current ratings are observed.

### ESD Ratings

ESD		Value	Unit
V(ESD)	Electrostatic Discharge	Human-Body Model (HBM)	5K
		Charged-Device Model (CDM)	2K

(1) JEDEC document JEP155 states that 500-V HBM allows safe manufacturing with a standard ESD control process.

(2) JEDEC document JEP157 states that 250-V CDM allows safe manufacturing with a standard ESD control process.

### Recommended Operating Conditions

Over operating free-air temperature range (unless otherwise noted)

Symbol	Parameter	Min	Max	Unit
V <sub>CC</sub>	Supply Voltage	1.8	5.5	V
T <sub>A</sub>	Operating Temperature	-40	85	°C

(1) All unused digital inputs of the device must be held at V<sub>CC</sub> or GND to ensure proper device operation.

### Thermal Information

Package Type	$\theta_{JA}$	$\theta_{JC}$	Unit
MSOP-10	180.7	66.2	°C/W
UFQFN-10(1.4x1.8)	120	46	°C/W

## Electrical Specifications

### DC Electrical Characteristics

V+ = 1.8V to 5.5 V, GND = 0V, FULL = -40°C to +85°C. Typical values are at T<sub>A</sub> = +25°C. (unless otherwise noted)

Parameter	Symbol	Conditions	V+	Temp	Min	Typ	Max	Units
<b>Analog Switch</b>								
On-Resistance	R <sub>ON</sub>	V <sub>IS</sub> = 0V to 0.4V, I <sub>b</sub> = 10mA, See Fig.8-1.	4.5V	+25°C		4.5	5	Ω
				Full			7	
			3V	+25°C		6.5	7	Ω
				Full			10	
On-Resistance Flatness	R <sub>FLAT</sub>	V <sub>IS</sub> = 0V to 1.0V, I <sub>b</sub> = 10mA, See Fig.8-1.	4.5V	+25°C		0.9	1.2	Ω
				Full			1.5	
			3V	+25°C		3.2	3.5	Ω
				Full			4.5	
On-Resistance Matching	ΔR <sub>ON</sub>	V <sub>IS</sub> = 0V to 0.4V, I <sub>b</sub> = 10mA, See Fig.8-1.	4.5V	+25°C		0.05	0.1	Ω
				Full			0.15	
			3V	+25°C		0.05	0.1	Ω
				Full			0.15	
Increase In I <sub>CC</sub> per Control Voltage	I <sub>CC</sub> T	V <sub>S</sub> or V <sub>IOE</sub> = 2.6 V	4.3V	Full			20	μA
Source Off Leakage Current	I <sub>HSD2(OFF)</sub> I <sub>HSD1(OFF)</sub>	V <sub>IS</sub> = 5V / 0.5V, V <sub>D</sub> = 0.5V / 5V	5.5V	Full			1	μA
Channel On Leakage Current	I <sub>HSD2(ON)</sub> I <sub>HSD1(ON)</sub>	V <sub>IS</sub> = 5V / 0.5V, V <sub>D</sub> = floating	5.5V	Full			1	μA
<b>Digital Control Inputs</b>								
Input High Voltage	V <sub>IH</sub>		3.3V	Full	1.7			V
Input Low Voltage	V <sub>IL</sub>		3.3V	Full			0.5	V
Input Leakage current	I <sub>IN</sub>	V <sub>S</sub> , V <sub>IOE</sub> = 0V or V+	5.5V	Full			1	μA
<b>Power Requirements</b>								
Power Supply Range	V+			Full	1.8		5.5	V
Quiescent Supply Current	I <sub>CC</sub>	V <sub>S</sub> , V <sub>IOE</sub> = 0V or V+	5.5V	Full			1	μA

## Electrical Specifications(Continued)

### Switch And AC Characteristics

V+=1.8V to 5.5 V, GND=0V, FULL=-40°C to +85°C. Typical values are at T<sub>A</sub>=+25°C. (unless otherwise noted)

Parameter	Symbol	Conditions	V+	Temp	Min	Typ	Max	Units
Turn-On Time	t <sub>ON</sub>	V <sub>IS</sub> =0.8V, R <sub>L</sub> =50Ω, C <sub>L</sub> =10pF, See Fig.8-2.	5V	+25°C		12		ns
			3.3V	+25°C		14		ns
Turn-Off Time	t <sub>OFF</sub>	V <sub>IS</sub> =0.8V, R <sub>L</sub> =50Ω, C <sub>L</sub> =10pF, See Fig.8-2.	5V	+25°C		6		ns
			3.3V	+25°C		8		ns
Break-Before-Make Delay	t <sub>BBM</sub>	V <sub>IS</sub> =0.8V, R <sub>L</sub> =50Ω, C <sub>L</sub> =10pF, See Fig.8-3.	5V	+25°C		5		ns
			3.3V	+25°C		4		ns
-3 dB Bandwidth	BW	Signal=0dBm, R <sub>L</sub> =50Ω C <sub>L</sub> =5pF, See Fig.8-6.	5V	+25°C		720		MHz
			3.3V	+25°C		700		MHz
Off-Isolation	OIRR	Signal=0dBm, R <sub>L</sub> =50Ω, f=250MHz, See Fig.8-4.	5V	+25°C		-32		dB
			3.3V	+25°C		-32		dB
Non-Adjacent Channel Crosstalk	XTALK	Signal=0dBm, R <sub>L</sub> =50Ω, f=250MHz, See Fig.8-5.	5V	+25°C		-41		dB
			3.3V	+25°C		-41		dB
Channel-to-Channel Skew	t <sub>SKEW</sub>	R <sub>L</sub> =50Ω, C <sub>L</sub> =10pF	5V	+25°C		0.1		ns
		R <sub>L</sub> =50Ω, C <sub>L</sub> =10pF	3.3V	+25°C		0.1		ns
Charge Injection	Q	R <sub>G</sub> =0Ω, C <sub>L</sub> =1nF, See Fig.8-7.	5V	+25°C		6		pC
		R <sub>G</sub> =0Ω, C <sub>L</sub> =1nF, See Fig.8-7.	3.3V	+25°C		4		pC
On Capacitance	C <sub>ON</sub>		5V	+25°C		6		pF

## Measurement Information

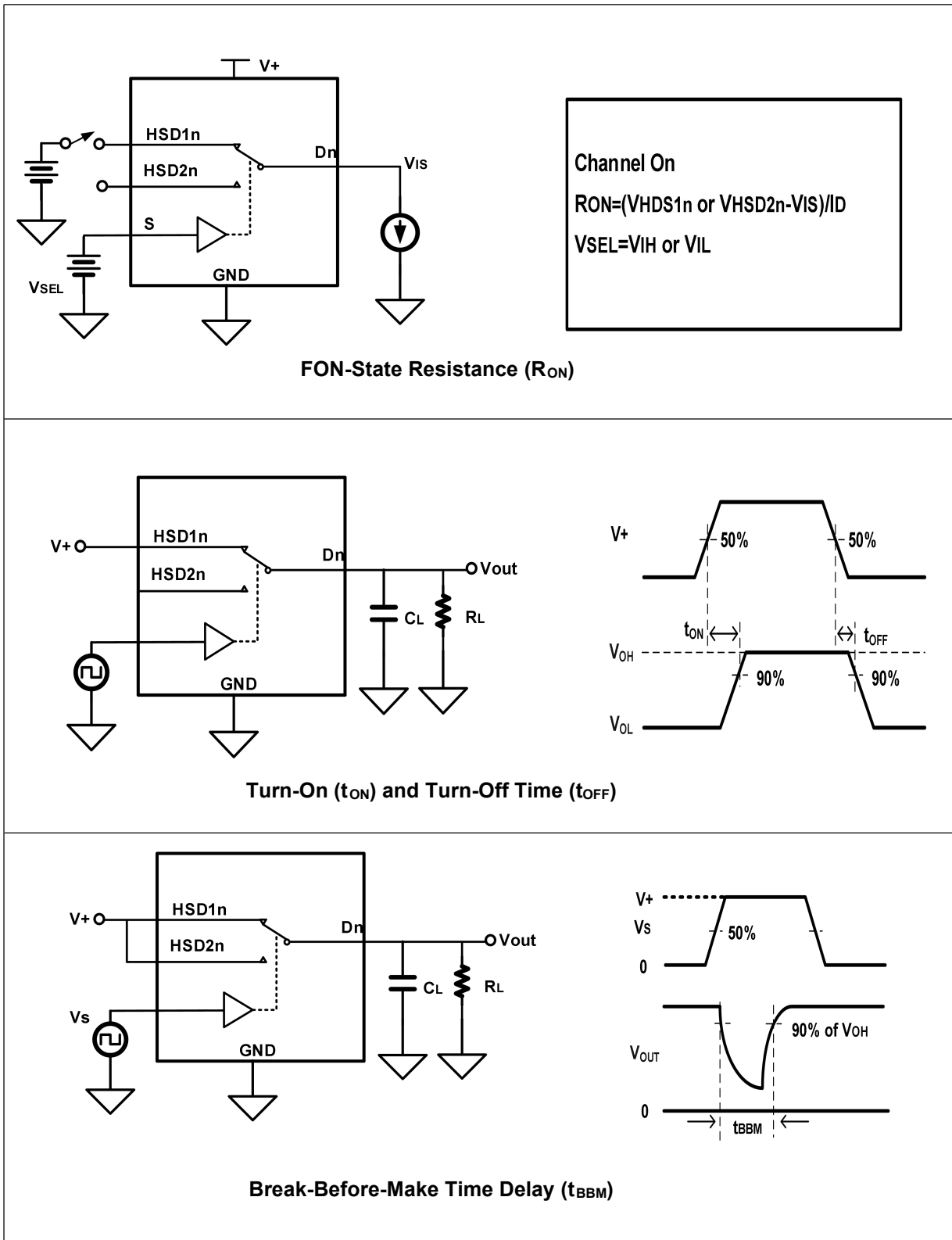

## Measurement Information (Continued)

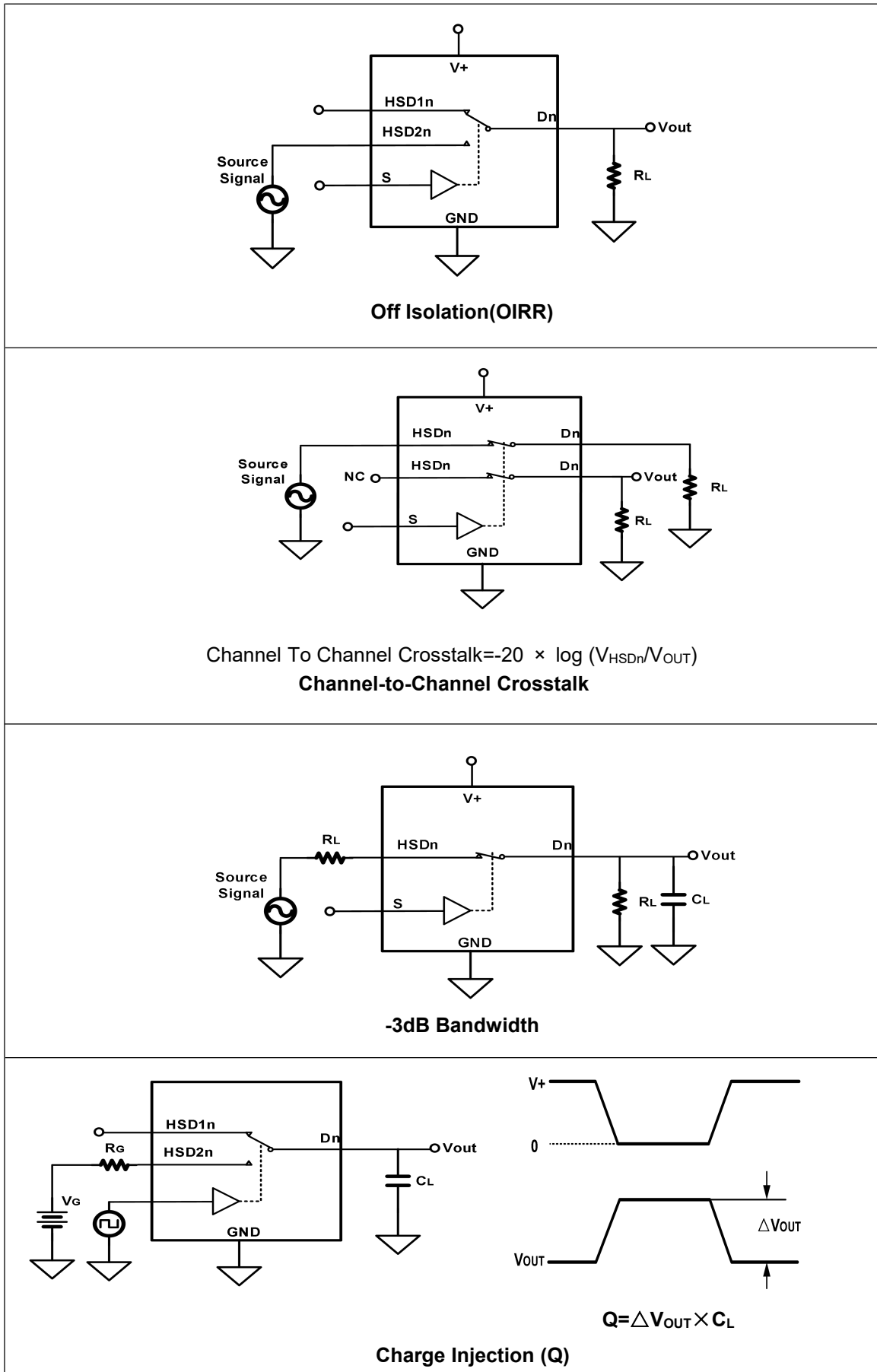

## Applications Note

There are many USB applications in which the USB hubs or controllers have a limited number of USB I/Os. The FSUSB42MUX/FSUSB42UMX solution can effectively expand the limited USB IOs by switching between multiple USB buses in order to interface them to a single USB hub or controller. FSUSB42MUX/FSUSB42UMX can also be used to connect a single controller to two USB connectors or controllers.

Design requirements of the USB 1.0, 1.1, and 2.0 standards should be followed. It is recommended that the digital control pins S and /OE be pulled up to V<sub>or</sub> down to GND to avoid undesired switch positions that could result from the floating pin.

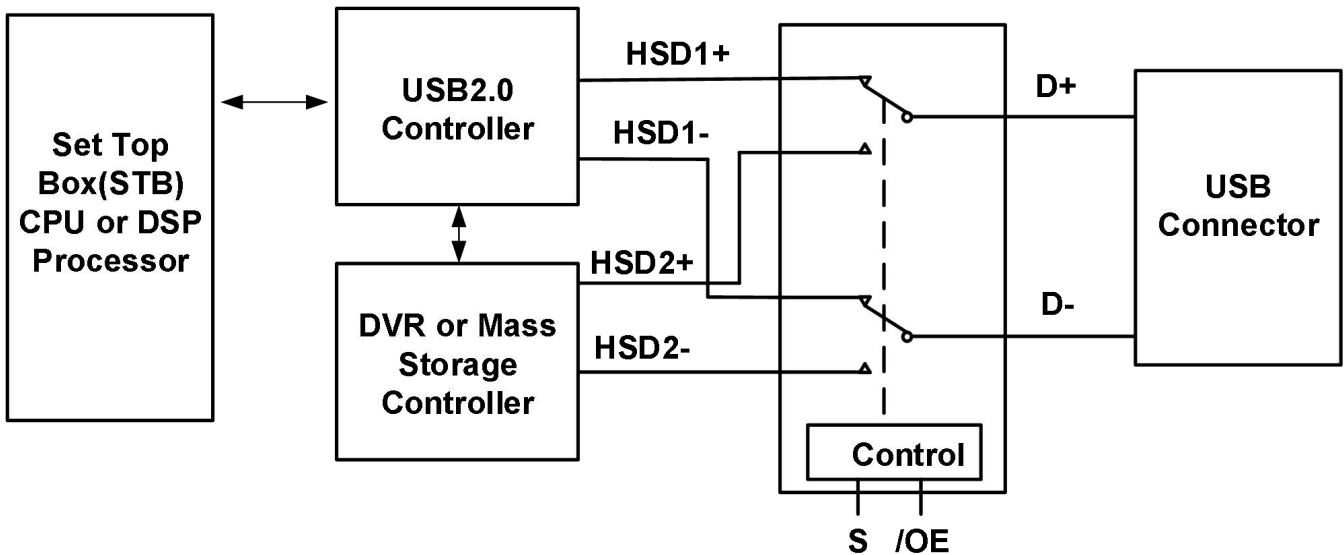

Application Diagram

## Eye Diagram Measurements

Eye Pattern: 480Mbps USB Signal with No Switch (Through Path)

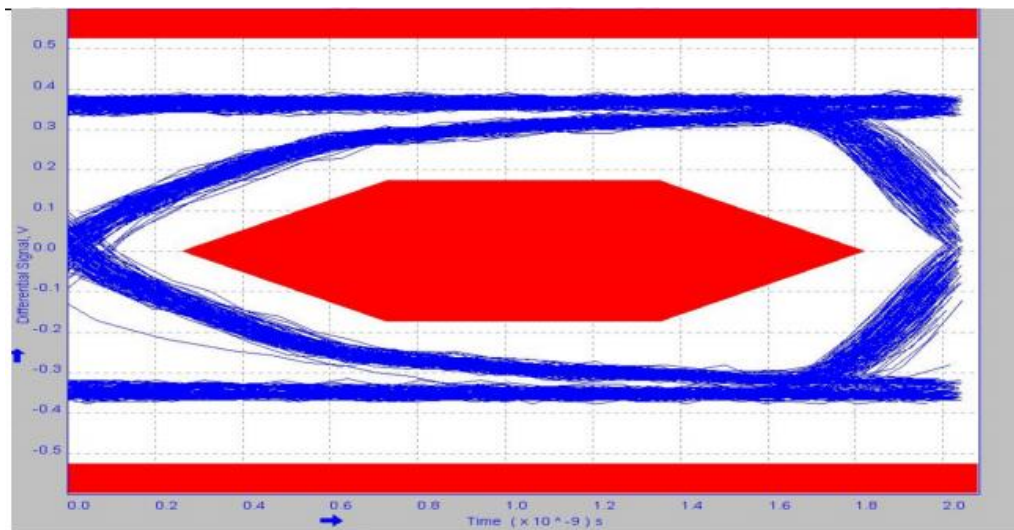

Eye Pattern:480Mbps USB Signal with Switch D+ Path

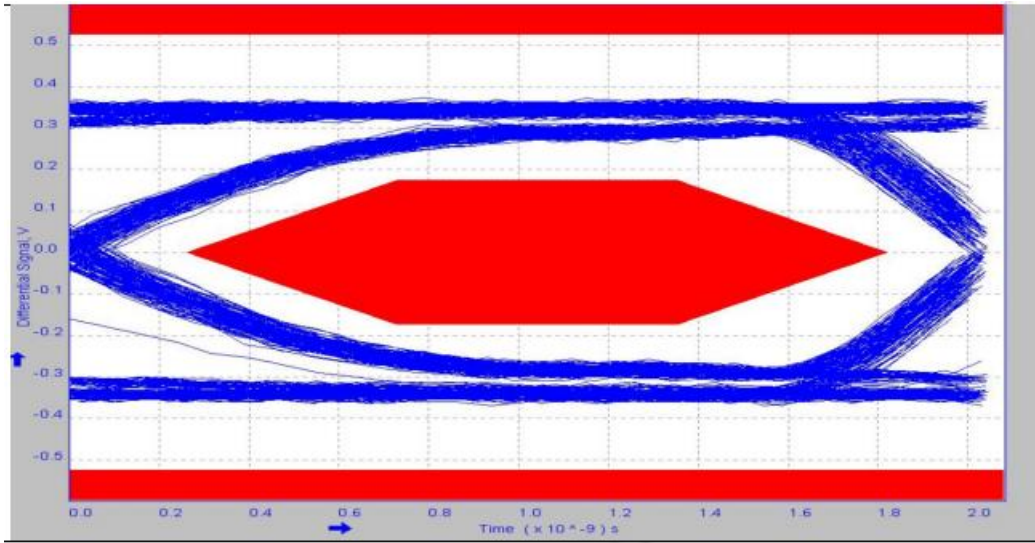

Eye Pattern:480Mbps USB Signal with Switch D- Path

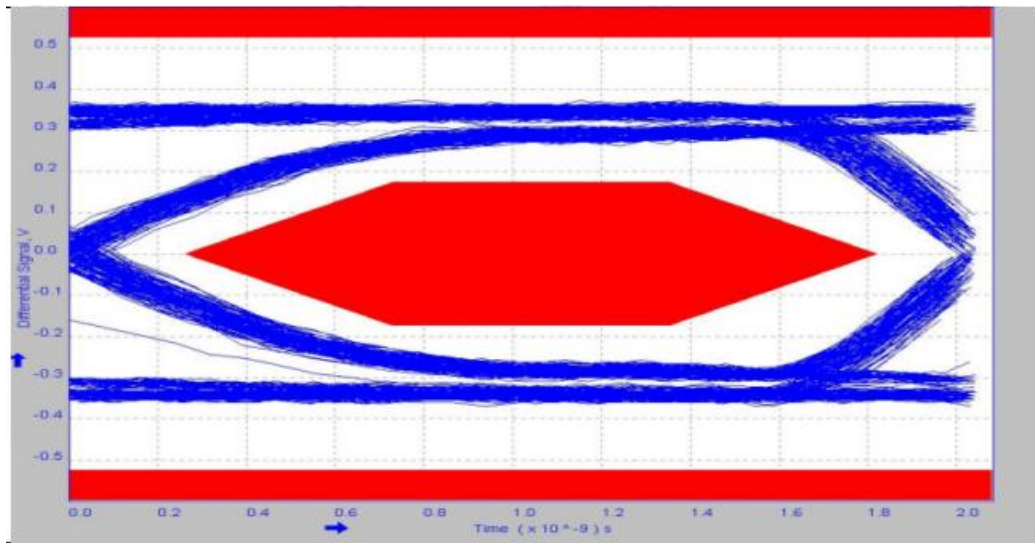

## Package Outline Dimension

### MSOP-10

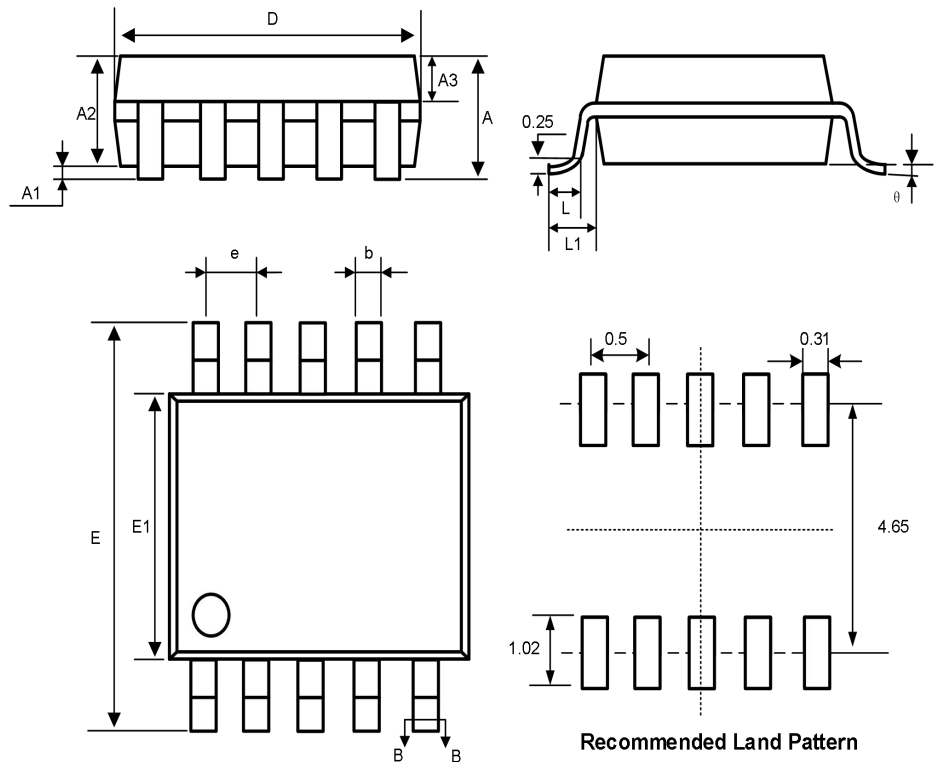

Symbol	Dimensions in Millimeters			Dimensions in Inches		
	Min.	Nom.	Max.	Min.	Nom.	Max.
A	—	—	1.10	—	—	0.043
A1	0.05	—	0.15	0.002	—	0.006
A2	1.30	1.40	1.50	0.051	0.055	0.059
A3	0.75	0.85	0.95	0.030	0.033	0.037
D	2.90	3.00	3.10	0.114	0.118	0.122
E	4.70	4.90	5.10	0.185	0.193	0.201
E1	2.90	3.00	3.10	0.114	0.118	0.122
e	0.50BSC			0.02BSC		
L	0.40	—	0.70	0.016	—	0.028
L1	0.95REF			0.037REF		
theta	0	—	8°	0	—	8°

## Package Outline Dimension(Continued)

UFQFN-10(1.4x1.8)

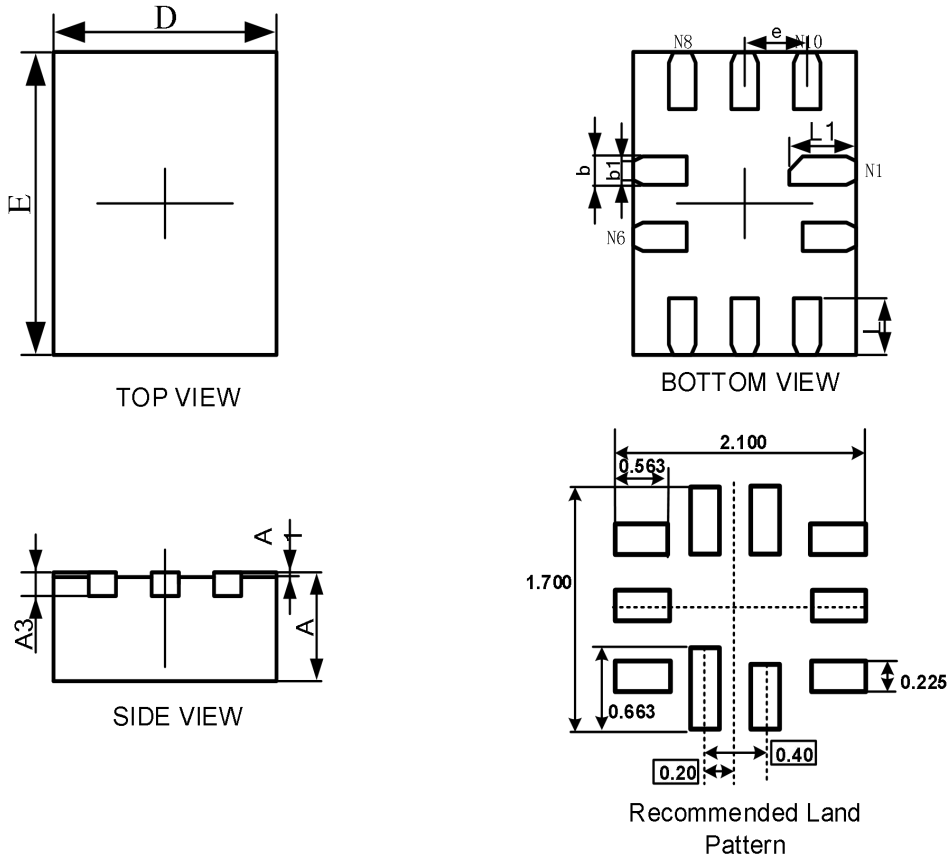

Symbol	Dimensions in Millimeters		Dimensions in Inches	
	Min	Max	Min	Max
A	0.500	0.600	0.020	0.024
A1	0.000	0.050	0.000	0.002
A3	0.152REF		0.006REF	
D	1.350	1.450	0.053	0.057
E	1.750	1.850	0.069	0.073
D1	—	—	—	—
E1	—	—	—	—
k	—		—	
b	0.150	0.250	0.006	0.010
b1	0.100	0.200	0.004	0.008
e	0.400TYP		0.016TYP	
L	0.350	0.450	0.014	0.018
L1	0.450	0.550	0.018	0.022