

# ITT Cannon CA-B/CB Series Bayonet Connectors



## 5015 PERFORMANCE WITH IMPROVED BAYONET COUPLING

ITT Cannon CA-B / CB series bayonet connectors are similar to standard MIL-DTL-5015 (MIL-5015), but use an improved coupling system - a quick-mating 3-point reverse-bayonet lock. ITT Cannon CA-B / CB series bayonet connectors have the same shell dimensions, contact layouts and performance characters as a standard 5015, but they are not intermateable. CA-B / CB bayonet connectors are harsh environment connectors excellent for military ground systems and vehicles. ITT Cannon CA-B / CB connectors are mil-spec, qualified to VG 95234 NATO specifications. Hundreds of contact layouts are available. Common variations include 2-pin connectors, 3-pin connectors, 4-pin connectors, 12-pin connectors and 16-pin connectors. The CA-B / CB is a waterproof connector that is completely sealed and resistant to condensation, vibration, and flash-over. For full product details on the CA-B / CB bayonet series, see the specifications below.

## APPLICATIONS

Industrial environments requiring extreme environmental reliability and ease of mating and unmating, such as:

- Power generators
- Battery systems
- Engines
- Sensors
- Motion control
- Off-road vehicles
- Earth-moving equipment
- Ships
- Railroad equipment
- Mobile equipment
- Industrial machinery
- Telecommunications

## FEATURES

### FULL MILITARY TEMPERATURE RANGE

CB connectors will operate in temperatures from -55° to +125°C (-67° to +257°F) under the harshest possible conditions.

### WIDE RANGE OF WIRE GAUGES AND CURRENT-CARRYING CAPABILITY

Up to 245 amps with wire gauges from size 26 up to size 0 AWG.

### RESILIENT INSULATOR & GROMMET

A resilient polychloroprene insulator and rear sealing grommet guarantees a liquid-tight assembly. Crimp contacts can be inserted and removed a minimum of five cycles for field service.

### WIDE VARIETY OF CONTACTS

High-reliability screw machine contacts with silver or gold plating are available in sizes from 20 through 0 to accommodate wire gauges from 24 to 0 AWG. Solder, crimp, PC, and thermocouple contacts are available.

### RUGGED SHELL

Aluminum alloy shell and hardware create a rugged connector with minimal weight. These connectors have been used extensively in the military for many years and have proven their reliability in a wide range of combat and industrial applications.

### ENVIRONMENTAL

Vibration and water-proof. Will perform in the full range of MIL-DTL-5015 or VG 95234 environments.

### SIMPLE MATING AND UN-MATING

CB bayonet style connectors use a unique "reverse bayonet" coupling system for ease of use. This system allows mating and un-mating of the connector halves with a simple 120° rotation - without compromising shock, vibration or moisture resistance. The coupling nut employs the exclusive Cannon "roller bolt" which is actually three small stainless steel wheels that roll down the mating ramps. The large, open ramps can be easily cleaned. The roller bolt and ramp coupling system eliminates the possibility of cross threading and thread damage possible with standard MIL-DTL-5015 threaded connectors. This quick mating design is easier to mate in cold weather, tight spaces, or on equipment which must be disassembled frequently.

**FEATURES (CONT.)**

**PROVEN RELIABILITY**

CA–Bayonet has been used extensively in military vehicles such as the M1 Tank, the Hummer, advanced locomotives, transit cars and auxiliary equipment.

**AUDIBLE, VISUAL & TACTILE CONFIRMATION OF MATING**

CB connectors provide the user with 3 independent checks that the connector halves are mated. When the coupling nut is fully rotated, the three roller bolts snap into the end of the ramps with a loud “click” (audible confirmation). At that same moment, the user can actually feel the bolts click into the grooves (tactile confirmation). A red arrow on the receptacle and a red dot on the coupling nut are aligned when the connector is properly mated (visual confirmation).

**ENVIRONMENTAL SEALING**

The sealing of this connector is not compromised by any of the operating conditions defined in MIL-DTL-5015 or VG 95234. Mated connectors are completely watertight when tested to 1 bar (35 feet) per the requirements of the VG 95234 specification. Unlike CT connectors, the receptacle contacts are not bonded into the inserts unless requested by the end user.

**INTERMATEABLE AND INTERMOUNTABLE WITH ALL VG 95234 CONNECTORS**

The standard MIL-DTL-5015 layouts and dimensions ensure intermateability and intermountability with all connectors made in accordance with VG 95234. When front mounted, all CB connectors are intermountable with standard threaded MIL-DTL-5015 connectors, making it possible to upgrade without the need to change panel cutouts or clearances in most cases.

**AGENCY APPROVALS**

Numerous European & International Rail Approvals (Contact us for current listing)  
 • VG 95234

**TECH SPECS**

**MATERIALS & FINISHES**

Shell	Aluminum alloy (shells can be grounded)
Shell Plating	Olive drab chromate coating over cadmium plating, black zinc cobalt, bright nickel or green zinc
Contacts	Copper alloy
Contact Platings	Hard silver plating or gold plating
Insulator*	Resilient polychloroprene (Neoprene)
Seals	Silicone or Neoprene

\*Optional zero halogen and high temperature insulators are available. Contact us for information.

**ELECTRICAL DATA**

Operating Voltage/Test Voltage According to MIL-DTL-5015

SERVICE RATING	OPERATING VOLTAGE		TEST VOLTAGE AC VRMS	AIR SPACING NOM. (INCHES)	CREEPAGE DISTANCE NOM. (INCHES)
	DC V	AC VRMS			
I	250	200	1,000	-	1/16
A	700	500	2,000	1/16	1/8
D	1,250	900	2,800	1/8	3/16
E	1,750	1,250	3,500	3/16	1/4
B	2,450	1,750	4,500	1/4	5/16

Current Rating at 68° F (+20°C)

CONTACT SIZE	(CB) MAX. CURRENT (AMPS)	CONTACT RESISTANCE MILLIOHM MAX.	POTENTIAL DROP (MILLIVOLTS)
16/16S	22	16	49
12	41	3	42
8	74	1	26
4	135	0.5	23
0	245	0.2	21

\*\*Maximum total current to be carried per connector in wire bundles as specified in MIL-W-5088. Contact resistance when tested to MIL-C-39029 will not exceed voltage drops listed in above table.

Wire Range Sizes 26 AWG to 0 AWG (↔ See contact selection chart pages 90-91)

Insulation Resistance CB/CA: >1000 megaohm (CA-Bayonet)  
 According to VG95319 Test 5.12 and VG95210 Part 32, Test condition B.

TECH SPECS

**MECHANICAL**

Operating Temperature	-55° to +125°C (-67° to +257°F) Neoprene
Sealing	Fully submersible to 1 bar (35 feet) when mated. Meets IP67, DIN 40 050, VG 95234.
Wire Sealing Range	The connector is designed for individual wire sealing. Sealing of an outer cable jacket on multiconductor cables must be accomplished with an appropriate endbell. Sealing is only guaranteed if wires according to MIL-W-5086 or within the listed ranges are used.

CONTACT SIZE	WIRE SIZE (MIL-W-5086)	INSULATION O.D. LIMIT			
		MIN. (INCHES)	MIN. (MM)	MAX. (INCHES)	MAX. (MM)
16	16	.087	2.2	.110	2.8
12	12	.122	3.1	.138	3.5
8	8	.220	5.6	.256	6.5
4	4	.335	8.5	.370	9.4
0	0	.452	11.5	.512	13.0

Mating Life	500 cycles minimum (to VG 95234)
Salt Spray	Meets VG 95234, Test 5.34
Heat	+125°C (+257°F) for 1000 hours
Chemical Resistance	Tested unmated and mated according to VG 95234 for hydraulic fluid, lubricating oil, fuels, humidity, water, salt water, solvents and corrosion resistance.
Vibration	200 m/s <sup>2</sup> at 10 to 2,000 Hz. To VG 95234 Test 5.16.
Shock	50g 11ms, three major axes. To VG 95234 Test 5.17.
Contact Type	Solder, crimp, PC, or thermocouple. Hard silver or gold plating.
Number of Circuits	1 to 65
Contact Insertion	From rear with simple hand tool. Removable, 5 cycles minimum.
Contact Retention	Pin and socket contacts are designed to resist severe vibration and repeated connection and disconnection. Contact retention and separation is tested according to VG 95319 Part 2. (Contact retention to test 5.4 with test force in mating direction. Separation force test 5.7 using required test gauge.)

CONTACT SIZE	RETENTION FORCE NEWTONS (LBS.)		SEPARATION FORCE MIN. NEWTONS (LBS.)		GAUGE	AXIAL LOAD NEWTONS (LBS.)		SEPARATION FORCE MIN. NEWTONS (LBS.)	
16	35	(7.9)	1	(.22)	G 1.56	44	(10)	1	(0.25)
12	55	(12.4)	1.5	(.34)	G 2.36	67	(15)	2	(0.5)
8	80	(18.0)	3	(.67)	G 3.58	89	(20)	3	(0.75)
4	90	(20.2)	4	(.90)	G 5.69	89	(20)	4	(1)
0	95	(21.4)	8.5	(1.9)	G 9.04	111	(25)	9	(2)

Polarization Key and keyway plus three point bayonet with optional rotational polarization.  
 ➡ See pages 81-89

Approvals/Specifications • VG 95234

CROSS SECTION

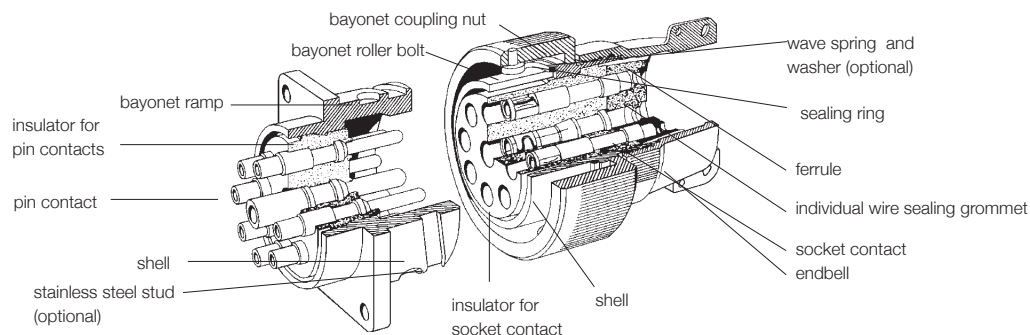

CREATE PART NUMBER								
1	2	3	4	5	6	7	8	9
<b>CB</b>	<b>6</b>	<b>E</b>		<b>10SL-3</b>	<b>P</b>		<b>S</b>	
<b>CONNECTOR TYPE</b>	<b>SHELL STYLE</b>	<b>ENDBELLS</b> (If omitting endbell, enter -)	<b>CABLE CLAMP/BOOT</b> (If needed)	<b>LAYOUT</b>	<b>CONTACT</b>	<b>POSITION</b> (omit for normal)	<b>CONTACT TYPE</b>	<b>PLATING</b>

**STEP 1: SELECT CONNECTOR TYPE**

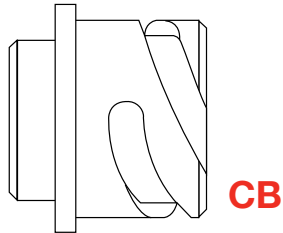

**STEP 2: SELECT SHELL STYLE, PLUG OR RECEPTACLE**

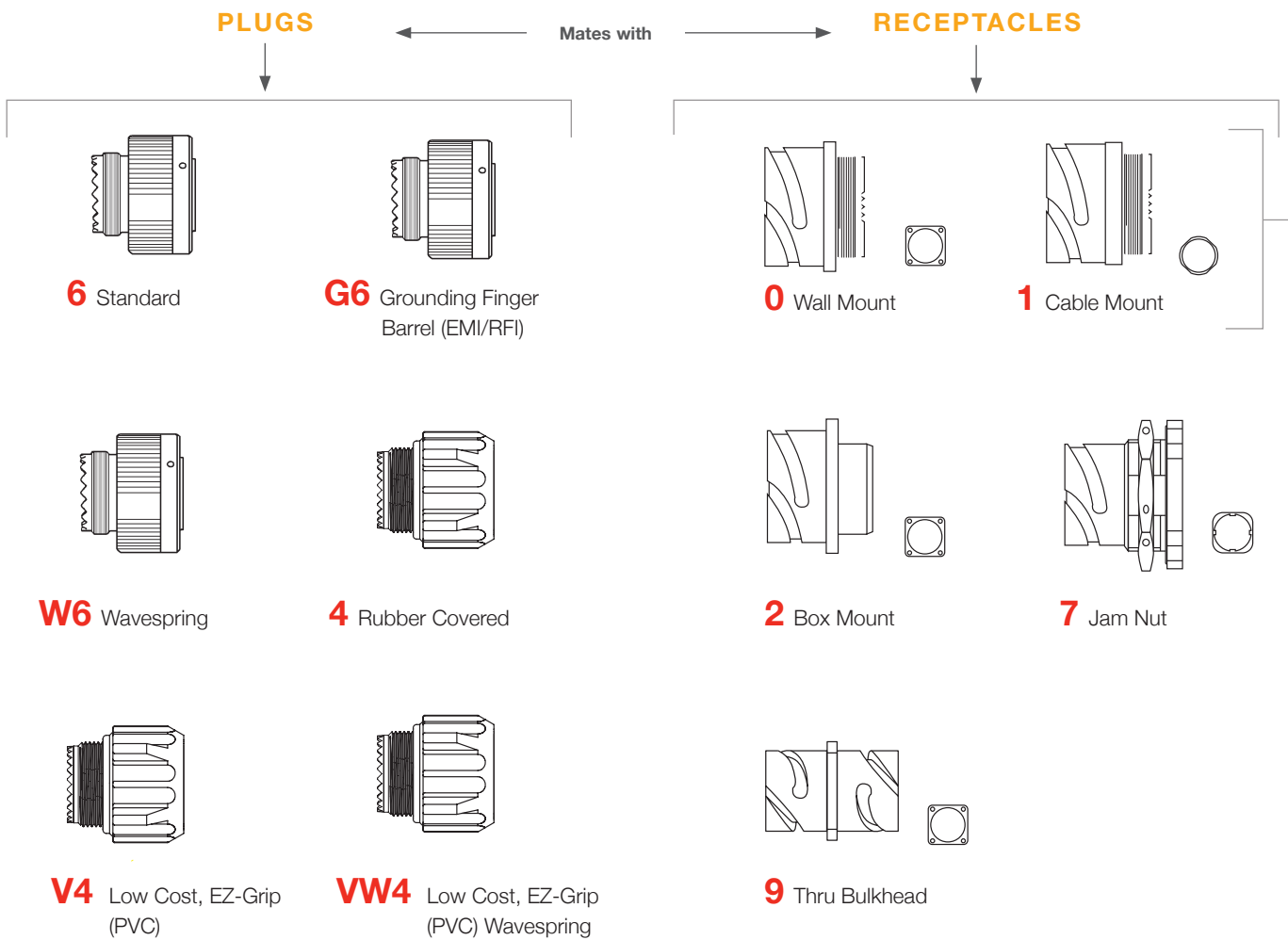

V4 and VW4 = for shell sizes 10S, 12S, 14S, 16S, 18, 20, 22 and 24

## STEP 3: CHOOSE ENDBELLS

⇒ See "Endbells" on pages 101-103 for a description of each endbell.

Mates with

<b>E</b> Standard Clamp (MS)	<b>R</b> No Clamp (MS)	<b>N</b> Heat Shrink	<b>U/D</b> Low Cost for Shielded for Unshielded Cable <b>U</b> - potted (preferred) <b>D</b> - uses grommets and ferrules	<b>M</b> Shielded Cable	<b>L</b> Long Extender
<b>F</b> Standard Extender	<b>T</b> 90° (MS)	<b>TP</b> Right Angle Endbell	<b>P</b> Potting (MS)	<b>J</b> Gland Seal	<b>PG</b> <sup>▲</sup> Low Cost Gland Seal
<b>PMA</b> <sup>▲</sup> Conduit ⇒ see pages 202-203	<b>NPT (I OR X)</b> <sup>▲</sup> <b>I</b> - Internal thread version <b>X</b> - External thread version	<b>PME</b> <sup>▲</sup> Shielded Conduit ⇒ see pages 202-203	<b>ST</b> <sup>▲</sup> Conduit		

## STEP 4: CHOOSE CABLE CLAMPS (IF APPLICABLE)

For Endbell Types: **N U/D M**

For Endbell Types: **L F T**

Heat Shrink Boot ⇒ See pages 196-201	<b>C</b> MS-3057-C	<b>A</b> MS-3057-A	9767 <sup>▲</sup>

## STEP 5: CHOOSE LAYOUT

⇒ See pages 76-89

## STEP 6: CHOOSE CONTACT

**P** = Pin      **S** = Socket      **PS** = Style 9 only

## STEP 7: CHOOSE ROTATION

⇒ See pages 81-89

**W**      **X**      **Y**      **Z**

## STEP 8: CHOOSE CONTACT TYPE

**S** = Solder      **H** = PC\*\*  
**C** = Crimp\*      **O** = Less contacts

## STEP 9: CHOOSE PLATING

### CONTACTS:

Omit for silver contacts

### SHELLS

Omit for standard\*\*\*

**AU** = Gold

**A34** = Bright Nickel 48 hr Salt Spray (RoHS, conductive, CB Series only)

**A232** = Black Zinc Cobalt 200 hr Salt Spray (RoHS, non-conductive, CB Series only)

**A233** = Green Zinc Cobalt 200 hr Salt Spray (RoHS, conductive, CB Series only)

**A239** = Black Zinc Cobalt 48 hr Salt Spray (RoHS, conductive, CB Series only)

**A240** = Blue Zinc Nickel 500 hr Salt Spray (RoHS, conductive, CB Series only)

\* When using a "C" in part number, the connector is supplied with the standard size crimp contacts for its layout (part number marked with "G#" in crimp Contact Selection Chart on ⇒ pages 90-91. If reduced or enlarged crimp contacts are required, specify connector 0 (less contacts) and order contacts separately.

\*\* Contact us for PC post diameters and lengths. Available for 16S, 16 and 12 size contacts.

▲ Contact us with NPT thread size, Sealtite conduit diameter or cable OD for D, NPT, ST, PG or endbell part number.

\*\*\*CB = Olive drab chromate over cadmium.

## LAYOUTS BY NUMBER OF CONTACTS

Key ▼ = CA/MS ● = CB View from mating face of pin insulator (\* = most popular layouts)  
 (socket view is opposite)

### 1 CONTACT

LAYOUT	8S-1	10S-2	12S-4	12-5	14S-4	16-12	18-6	18-7	20-2	22-7
# OF CONTACTS	1-#16	1-#16	1-#16	1-#12	1-#16	1-#4	1-#4	1-#8	1-#0	1-#0
SERIES	▼	▼	▼●	▼	●	▼●	●	▼●	▼●	▼●
SERVICE RATING	A	A	D	D	D	A	D	B	D	E

### 2 CONTACTS

LAYOUT	10SL-4*	12S-3*	14S-9*	16S-4	16-11	18-3	20-23
# OF CONTACTS	2-#16	2-#16	2-#16	2-#16	2-#12	2-#12	2-#8
SERIES	▼●	▼●	▼●	▼●	▼●	▼●	▼●
SERVICE RATING	A	A	D	A	A	D	A

LAYOUT	22-1	22-8	22-11	24-9	28-7	32-5
# OF CONTACTS	2-#8	2-#12	2-#16	2-#4	2-#4	2-#0
SERIES	●	▼●	▼	▼●	▼	▼●
SERVICE RATING	D	E	B	A	D	D

### 3 CONTACTS

LAYOUT	10SL-3*	14S-1	14S-7*	16S-5	16S-6	16-7	16-10*	18-5	18-21	18-22
# OF CONTACTS	3-#16	3-#16	3-#16	3-#16	3-#16	2-#16; 1-#8	3-#12	1-#16; 2-#12	3-#12	3-#16
SERIES	▼●	▼●	▼●	▼●	▼●	●	▼●	▼●	●	▼●
SERVICE RATING	A	A	A	A	A	A	A	D	D	D

LAYOUT	20-3	20-6	20-19	22-2	22-6	22-9	22-21	36-4
# OF CONTACTS	3-#12	3-#16	3-#8	3-#8	1-#16; 2-#8	3-#12	2-#16; 1-#0	3-#0
SERIES	▼●	●	▼●	▼●	▼	▼●	●	▼
SERVICE RATING	D	D	A	D	D	E	A	D(A); A(B,C)

### 4 CONTACTS

LAYOUT	12SA-10	14S-2*	16-9	18-4*	18-10*	18-13	20-4*	20-24	22-4
# OF CONTACTS	4-#16	4-#16	2-#16; 2-#12	4-#16	4-#12	3-#12; 1-#8	4-#12	2-#16; 2-#8	2-#12; 2-#8
SERIES	▼●	▼●	▼●	▼●	▼●	▼●	▼●	▼●	▼●
SERVICE RATING	I	I	A	D	A	A	D	A	A

# LAYOUTS BY NUMBER OF CONTACTS

Key ▼ = CA/MS ● = CB View from mating face of pin insulator (socket view is opposite) \* = most popular layouts

## 4 CONTACTS

LAYOUT	22-10	22-22*	24-4	24-22*	32-17	36-5
# OF CONTACTS	4-#16	4-#8	3-#16; 1-#0	4-#8	4-#4	4-#0
SERIES	▼●	▼●	●	▼●	▼●	▼●
SERVICE RATING	E	A	D	D	D	A

## 5 CONTACTS

LAYOUT	10SLA4	14S-5*	16S-8*	18-11*	18-20	20-14	22-12	22-13	24-12
# OF CONTACTS	5-#20	5-#16	5-#16	5-#12	5-#16	3-#12; 2-#8	3-#16; 2-#8	1-#16; 4-#12	3-#12; 2-#4
SERIES	▼●	▼●	▼●	▼●	●	▼●	▼●	▼●	▼●
SERVICE RATING	A	I	A	A	A	A	D	A(A,D); D(E)	A

## 5 CONTACTS

LAYOUT	28-5	32-1
# OF CONTACTS	2-#16; 1-#12; 2-#4	3-#12; 2-#0
SERIES	▼●	▼●
SERVICE RATING	D	E(A); D(balance)

## 6 CONTACTS

LAYOUT	14S-6*	18-12	20-8	20-17	20-22
# OF CONTACTS	6-#16	6-#16	4-#16; 2-#8	1-#16; 5-#12	3-#16; 3-#8
SERIES	▼●	▼●	▼●	▼●	▼●
SERVICE RATING	I	A	I	A	A

LAYOUT	22-5	22-15	28-22	36-3	36-6
# OF CONTACTS	4-#16; 2-#12	1-#16; 5-#12	3-#16; 3-#4	3-#12; 3-#0	4-#4; 2-#0
SERIES	●	▼●	▼●	▼●	▼●
SERVICE RATING	D	A(A,B,C,E,F); E(D)	D	D	A

## 7 CONTACTS

LAYOUT	14SA7	16S-1*	18-9	20-15*	22-28	24-2	24-10	24-27	28-10
# OF CONTACTS	7#16	7-#16	5-#16; 2-#12	7-#12	7-#12	7-#12	7-#8	7-#16	3-#12; 2-#8; 2-#4
SERIES	▼●	▼●	▼●	▼●	▼●	▼●	▼●	▼●	▼●
SERVICE RATING	I	A	I	A	A	D	A	E	D(G); A(balance)

## 8 CONTACTS

LAYOUT	18-8*	20-7*	22-18	22-23	24-6	32-15	36A35
# OF CONTACTS	7-#16; 1-#12	8-#16	8-#16	8-#12	8-#12	6-#12; 2-#0	4-#16; 4-#0
SERIES	▼●	▼●	▼●	▼●	●	▼●	●
SERVICE RATING	A	A(C-F) D(balance)	A(C-E)	D(H); A(balance)	D(A,G,H); A(balance)	D	A







# LAYOUTS BY NUMBER OF CONTACTS

Key ▼ = CA/MS ● = CB

View from mating face of pin insulator  
(socket view is opposite)

\* = most popular layouts

	17 CONTACTS	18 CONTACTS	19 CONTACTS	
LAYOUT				
# OF CONTACTS	20-29*	36A16	20A48	22-14*
SERIES	17-#16	18-#12	19-#16	19-#16
SERVICE RATING	▼● A	▼ A	● I	▼● A
	20 CONTACTS	22 CONTACTS	23 CONTACTS	
LAYOUT				
# OF CONTACTS	28-16	28-11*	32-6	32-13
SERIES	20-#16	18-#16; 4-#12	16-#16; 2-#12; 3-#8; 2-#4	18-#16; 5-#12
SERVICE RATING	▼● A	▼● A	▼● A	● D
	24 CONTACTS	26 CONTACTS	27 CONTACTS	28 CONTACTS
LAYOUT				
# OF CONTACTS	24-28*	28-12*	36A46	24A28
SERIES	24-#16	26-#16	27-#12	28-#16
SERVICE RATING	▼● I	▼● A	▼● A	● I
				28A63
				9-#12; 19-#16
				● A
	30 CONTACTS	31 CONTACTS	35 CONTACTS	
LAYOUT				
# OF CONTACTS	32-8	36-9	28-15*	32-7*
SERIES	24-#16; 6-#12	14-#16; 14-#12; 2-#8; 1-#4	35-#16	28-#16; 7-#12
SERVICE RATING	▼● A	▼● A	▼● A	▼● I (A,B,H,J); A (balance)
	35 CONTACTS	37 CONTACTS		
LAYOUT				
# OF CONTACTS	36-15	28-21*		
SERIES	35-#16	37-#16		
SERVICE RATING	▼● D(m); A(balance)	▼● A		

LAYOUTS BY NUMBER OF CONTACTS

Key ▼ = CA/MS ● = CB

View from mating face of pin insulator  
(socket view is opposite)

\* = most popular layouts

39 CONTACTS

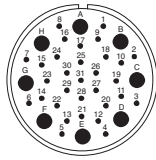

LAYOUT 36A98  
# OF CONTACTS 8-#8; 31-#16  
SERIES ●  
SERVICE RATING I

43 CONTACTS

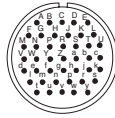

28A51  
43-#16  
▼ ●  
A

47 CONTACTS

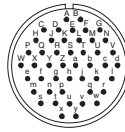

32A47  
47-#16  
▼ ●  
A

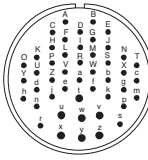

36-7\*  
40-#16; 7-#12  
▼ ●  
A

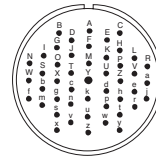

36-8  
46-#16; 1-#12  
▼ ●  
A

48 CONTACTS

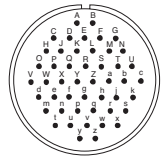

36-10\*  
48-#16  
▼ ●  
A

52 CONTACTS

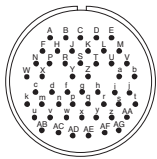

LAYOUT 36A34  
# OF CONTACTS 52-#16  
SERIES ▼ ●  
SERVICE RATING A

54 CONTACTS

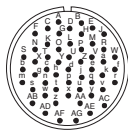

32A10  
54-#16  
▼ ●  
A

55 CONTACTS

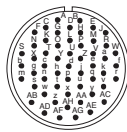

32A55  
55-#16  
●  
A

56 CONTACTS

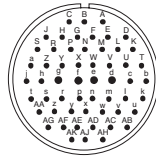

36A66  
52-#16; 4-#12  
▼  
A

61 CONTACTS

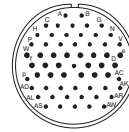

32A69  
20-#16; 41-#20  
●  
A

65 CONTACTS

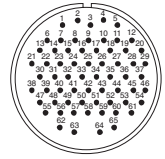

36A99  
50-#20; 15-#16  
●  
I

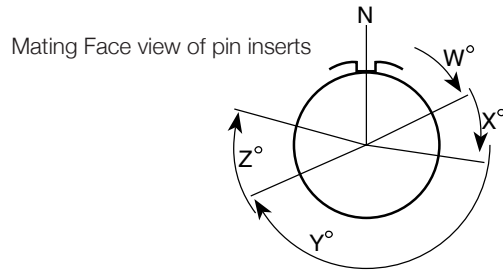

CONTACT METALLURGY KEY: **ALUMEL (AL.)** **CHROMEL (CH.)** **CONSTANTAN (CON.)** **COPPER (CU)** **IRON (IR.)** **THERMOCOUPLE (†)**

LAYOUT	SERIES				TOTAL	CONTACT SIZES						†	DEGREES OF ROTATION				SERVICE RATING
	MS	CT	CB	VG		20	16	12	8	4	0		W	X	Y	Z	
8S-1	△	▲			1		1						-	-	-	-	A
10S-2	△	▲			1		1						-	-	-	-	A
10SL-3	△	▲	●	○	3		3						-	-	-	-	A
10SL-4	△	▲	●	○	2		2						-	-	-	-	A
10SL-51		▲	●		2		2					†	10SL-4 45° A=IR.; B=CON.				
10SL-52		▲	●		2		2					†	10SL-4 45° A=CU; B=CON.				
10SL-53		▲	●		2		2					†	10SL-4 45° A=AL.; B=CH.				
10SL-54		▲	●		3		3					†	10SL-3 A=IR.; B=CON.; C=CU				
10SL-55		▲	●		3		3					†	10SL-3 A=AL.; B=CH.; C=CU				
10SL-56		▲	●		2		2					†	10SL-4 A=AL.; B=CH.				
10SL-57		▲	●		2		2					†	10SL-4 A=CH.; B=CON.				
10SL-58		▲	●		3		3					†	10SL-3 A=CH.; B=AL.; C=CU				
10SL-59		▲	●		2		2					†	10SL-4 A=CH.; B=AL.				
10SL-60		▲	●		2		2					†	10SL-4 A=IR.; B=CON.				
10SL-61		▲	●		2		2					†	10SL-4 A=CU; B=CON.				
10SL-62		▲	●		3		3					†	10SL-3 A=CU; B=AL.; C=IR.				
10SL-63		▲	●		3		3					†	10SL-3 A, C=CON.; B=CH.				
10SL-64		▲	●		3		3					†	10SL-3 A, C=CH.; B=AL.				
10SL-A4		▲	●		5	5							CONTACT US FOR VALID ROTATIONS				A
12S-1		▲	●		2		2						12S-3 100°				A
12S-2		▲	●		2		2						12S-3 250°				A
12S-3	△	▲	●		2		2						70	145	215	290	A
12S-4	△	▲	●		1		1						-	-	-	-	D
12S-51		▲	●		2		2					†	12S-3 315° A=CH.; B=AL.				
12S-54		▲	●		2		2					†	12S-3 315° A = IR.; B=CON.				
12S-55		▲	●		2		2					†	12S-3 45° A=CU; B=CON.				
12S-56		▲	●		2		2					†	12S-3 A=AL.; B=CH.				
12S-57		▲	●		2		2					†	12S-3 60° A=CH.; B=AL.				
12S-58		▲	●		2		2					†	12S-3 120° A=IR.; B=CON.				
12S-59		▲	●		2		2					†	12S-3 A=IR.; B=CON.				
12S-60		▲	●		2		2					†	12S-3 A=CU; B=CON.				
12S-61		▲	●		2		2					†	12S-3 A=CH.; B=CON.				
12S-62		▲	●		2		2					†	12S-3 A=CH.; B=AL.				
12SA10		▲	●										CONTACT US FOR VALID ROTATIONS				I
12-5	△	▲			1			1					-	-	-	-	D
14S-1	△	▲	●		3		3						-	-	-	-	A
14S-2	△	▲	●		4		4						-	120	240	-	I

LAYOUTS BY SHELL SIZE

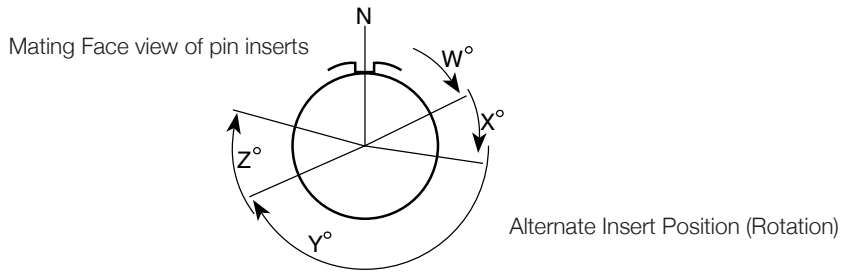

CONTACT METALLURGY KEY: **ALUMEL (AL.)** **CHROMEL (CH.)** **CONSTANTAN (CON.)** **COPPER (CU)** **IRON (IR.)** **THERMOCOUPLE (⊕)**

LAYOUT	SERIES				TOTAL	CONTACT SIZES						⊕	DEGREES OF ROTATION				SERVICE RATING
	MS	CT	CB	VG		20	16	12	8	4	0		W	X	Y	Z	
14S-4			●		1		1						-	-	-	-	D
14S-5	△	▲	●		5		5						-	110	-	-	I
14S-6	△	▲	●	○	6		6						-	-	-	-	I
14S-7	△	▲	●		3		3						90	180	270	-	A
14S-9	△	▲	●		2		2						70	145	215	290	A
14S-10		▲	●		4		4						14S-2 100°				I
14S-11		▲	●		4		4						14S-2 250°				I
14S-12		▲	●		3		3						14S-1 100°				A
14S-13		▲	●		3		3						14S-1 260°				A
14S-14		▲	●		4		4						14S-2 100°				I
14S-51		▲	●		2		2					⊕	14S-9 90° A=AL.; B=CH.				
14S-52		▲	●		4		4					⊕	14S-2 45° A, B=CU; C=AL.; D=CH.				
14S-53		▲	●		2		2					⊕	14S-9 90° A=IR.; B=CON.				
14S-54		▲	●		6		6					⊕	14S-6 45° A, C, E=IR.; B, D, F=CON.				
14S-55		▲	●		4		4					⊕	14S-2 45° A, C=IR.; B, D=CON.				
14S-56		▲	●		4		4					⊕	14S-2 45° A=IR.; B=CON.; C, D=CU				
14S-57		▲	●		4		4					⊕	14S-2 45° A, C=AL.; B, D=CH.				
14S-58		▲	●		3		3					⊕	14S-7 45° A=AL.; B=CH.; C=CU				
14S-59		▲	●		2		2					⊕	14S-9 90° A=CU; B=CON.				
14S-60		▲	●		2		2					⊕	14S-9 A=AL.; B=CH.				
14S-61		▲	●		6		6					⊕	14S-6 45° A=AL.; B=CH.; C=IR.; D=CON.; E, F=CU				
14S-63		▲	●		6		6					⊕	14S-6 A, C=AL.; B, D=CH.; E=IR.; F=CON.				
14S-64		▲	●		4		4					⊕	14S-2 A, C=CON.; B, D=CU				
14S-65		▲	●		6		6					⊕	14S-6 A, C, E=CU; B, D, F=CON.				
14S-67		▲	●		6		6					⊕	14S-6 A=AL.; B=CH.; BALANCE=CU				
14S-68		▲	●		4		4					⊕	14S-2 45° A=CH.; B=CON.; C, D=CU				
14S-69		▲	●		3		3					⊕	14S-7 A=CON.; B=CH.; C=CU				
14S-70		▲	●		4		4					⊕	14S-2 A, D=CH.; B, C=AL.				
14S-71		▲	●		4		4					⊕	14S-2 A, B, D=CU; C=CON.				
14S-72		▲	●		2		2					⊕	14S-9 A=CON.; B=CU				
14S-73		▲	●		4		4					⊕	14S-2 A, B=CU; C=AL.; D=CH.				
14S-74		▲	●		4		4					⊕	14S-2 A, B=CH.; C, D=AL.				
14S-75		▲	●		4		4					⊕	14S-2 A, B=CU; C, D=CON.				
14S-76		▲	●		4		4					⊕	14S-2 A, C=AL.; B, D=CH.				
14S-77		▲	●		4		4					⊕	14S-2 A, D=AL.; B, C=CH.				

LAYOUTS BY SHELL SIZE

CONTACT METALLURGY KEY: **ALUMEL (AL.)** **CHROMEL (CH.)** **CONSTANTAN (CON.)** **COPPER (CU)** **IRON (IR.)** **THERMOCOUPLE (T)**

LAYOUT	SERIES				TOTAL	CONTACT SIZES						T	DEGREE OF ROTATION				SERVICE RATING
	MS	CT	CB	VG		20	16	12	8	4	0		W	X	Y	Z	
14S-78		▲	●		2		2					T	14S-9 A=CH.; B=AL.				
14SA7		▲	●		7		7						-	-	-	-	A
14-3	△	▲			1				1				-	-	-	-	A
16S-1	△	▲	●	○	7		7						80	-	-	280	A
16S-4	△	▲	●	○	2		2						35	110	250	325	D
16S-5	△	▲	●		3		3						70	145	215	290	A
16S-6	△	▲	●		3		3						90	180	270	-	A
16S-8	△	▲	●		5		5						-	170	265	-	A
16S-14		▲	●		3		3						16S-4 110°				A
16S-15		▲	●		2		2						16S-5 100°				D
16S-16		▲	●		2		2						16S-4 250°				D
16S-17		▲	●		3		3						16S-5 250°				A
16S-52		▲	●		2		2				T		16S-4 A=CH.; B=AL.				
16S-54		▲	●		7		7				T		16S-1 A=AL.; B=CH.; BALANCE=CU				
16S-55		▲	●		7		7				T		16S-1 A=CON.; BALANCE=CU				
16SA18		▲	●		7		7						16S-1 100°				A
16SA19		▲	●		7		7						16S-1 260°				A
16SA20		▲	●		7		7						16S-1 110°				A
16SA21		▲	●		7		7						16S-1 250°				A
16-7		▲	●	○	3		2		1				80	110	250	280	A
16-9	△	▲	●		4		2	2					35	110	250	325	A
16-10	△	▲	●	○	3			3					90	180	270	-	A
16-11	△	▲	●		2			2					35	110	250	325	A
16-12	△	▲	●	○	1				1				-	-	-	-	A
16-13	△	▲	●		2			2			T		35	110	250	325	A=IR ; B CON
16-52		▲	●		2			2			T		16-11 90° A=AL.; B=CH.				
16-53		▲	●		4		2	2			T		16-9 70° A=AL.; C=CH.; B, D=CU				
16-55		▲	●		3			3			T		16-10 45° A=AL.; B=CH.; C=CU				
16-56		▲	●		2			2			T		16-13 90° A=CON.; B=CU				
16-57		▲	●		3			3			T		16-10 A=AL.; B=CU; C=CH.				
16-58		▲	●		3			3			T		16-10 A=CON.; B, C=CU				
16-60		▲	●		2			2			T		16-13 A=AL.; B=CH.				
16-62		▲	●		2			2			T		16-11 A=CON.; B=CU				
18-1	△	▲	●	○	10		10						70	145	215	290	A(B,C,F,G); I(all others)
18-3	△	▲	●		2			2					35	110	250	325	D
18-4	△	▲	●		4		4						35	110	250	325	D
18-5	△	▲	●		3		1	2					80	110	250	280	D
18-6	△	▲	●		1				1				-	-	-	-	D
18-7	△	▲	●		1				1				-	-	-	-	B
18-8	△	▲	●		8		7	1					70	-	-	290	A
18-9	△	▲	●		7		5	2					80	110	250	280	I
18-10	△	▲	●		4			4					-	120	240	-	A
18-11	△	▲	●	○	5			5					-	170	265	-	A
18-12	△	▲	●		6		6						80	-	-	280	A
18-13	△	▲	●	○	4			3	1				80	110	250	280	A
18-15	△	▲	●		4			4			T		18-10 315° A, C=IR.; B, D=CON.				

LAYOUTS BY SHELL SIZE

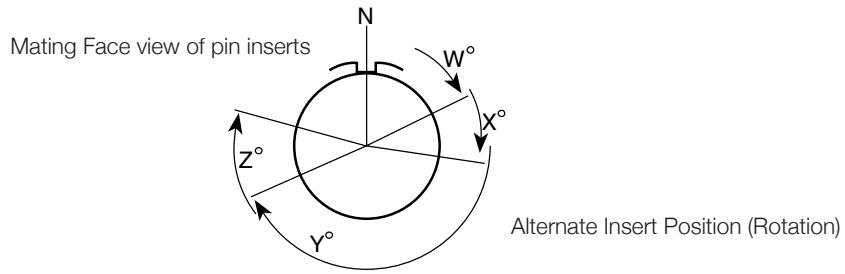

CONTACT METALLURGY KEY: **ALUMEL (AL.)** **CHROMEL (CH.)** **CONSTANTAN (CON.)** **COPPER (CU)** **IRON (IR.)** **THERMOCOUPLE (⊕)**

LAYOUT	SERIES				TOTAL	CONTACT SIZES						⊕	DEGREES OF ROTATION				SERVICE RATING
	MS	CT	CB	VG		20	16	12	8	4	0		W	X	Y	Z	
18-17		▲	●		7		5	2					18-9 100°				I
18-18		▲	●		7		5	2					18-9 250°				I
18-19		▲	●		10		10						-	120	240	-	A
18-20		▲	●		5		5						90	180	270	-	A
18-21			●		3			3					70	145	215	290	D
18-22	△	▲	●		3		3						70	145	215	290	D
18-23		▲	●		10		10						18-1 100°				A(B,C,F,G); I(all others)
18-24		▲	●		10		10						18-1 250°				A(B,C,F,G); I(all others)
18-25		▲	●		2			2					18-3 100°				D
18-26		▲	●		2			2					18-3 250°				D
18-27		▲	●		3		1	2					18-5 100°				D
18-28		▲	●		3		1	2					18-5 250°				D
18-29		▲			5		5						90	180	270	-	A
18-30		▲	●		5		5						18-20 110°				A
18-31		▲	●		5		5						18-20 260°				A
18-51		▲	●		6		6					⊕	18-12 A=IR.;B,E=CON.;D=CU;C, F=DUMMY				
18-52		▲	●		5			5				⊕	18-11 A=IR.;B=CON.;C=CH.;D=AL.;E=DUMMY				
18-53		▲	●		6		6					⊕	18-12 A, D=IR.; B, E=CON.; C, F=DUMMY				
18-54		▲	●		4			4				⊕	18-15 A, C=AL.; B, D=CH.				
18-56		▲	●		10		10					⊕	18-1 45° A, C, E, G, I=IR.; B, D, F, H, J=CON.				
18-57		▲	●		6		6					⊕	18-12 45° A, C, E=AL.; B, D, F=CH.				
18-59		▲	●		6		6					⊕	18-12 45° A, C=IR.; B, E, F=CON.; D=CU				
18-60		▲	●		5			5				⊕	18-11 45° A, D=AL.; B, C,=CH.; E=CU				
18-61		▲	●		6		6					⊕	18-12 A, C=IR.; B, D=CON.; E=CH.; F=AL.				
18-62		▲	●		6		6					⊕	18-12 A, B, C=IR.; D, E, F=CON.				
18-63		▲	●		4			4				⊕	18-15 A, C=CON.; B, D=CU				
18-65		▲	●		6		6					⊕	18-12 A=IR.; B=CON.; BALANCE=CU				
18-66		▲	●		10		10					⊕	18-1 A, C, E, G, I=CU; B, D, F, H, J=CON.				
18-67		▲	●		6		6					⊕	18-12 A, C, E=CU; B, D, F=CON.				
18-68		▲	●		5			5				⊕	18-11 A, D=AL.; B, C=CH.; E=CU				
18-69		▲	●		10		10					⊕	18-1 A=AL.; B=CH.; BALANCE=CU				
18-70		▲	●		5			5				⊕	18-11 A=IR.; B=CON.; C=CH.; D=AL.; E=CU				
18-71		▲	●		4			4				⊕	18-15 A=CON.; BALANCE=CU				
18-72		▲	●		4			4				⊕	18-15 D=CON.; BALANCE=CU				
18-73		▲	●		7		5	2				⊕	18-9 A=AL.; D=CH.; BALANCE=CU				
18-74		▲	●		6		6					⊕	18-12 A=CH.; B=AL.; D=IR.; E=CU; C, F=CON.				

# LAYOUTS BY SHELL SIZE

CONTACT METALLURGY KEY: **ALUMEL (AL.) CHROMEL (CH.) CONSTANTAN (CON.) COPPER (CU) IRON (IR.) THERMOCOUPLE (T)**

LAYOUT	SERIES				TOTAL	CONTACT SIZES						T	DEGREE OF ROTATION				SERVICE RATING
	MS	CT	CB	VG		20	16	12	8	4	0		W	X	Y	Z	
18A31		▲	●		10		10						18-1 110°				A(B,C,F,G); I(all others)
20-2	△	▲	●	○	1						1		-	-	-	-	D
20-3	△	▲	●		3			3					70	145	215	290	D
20-4	△	▲	●		4			4					45	110	250	-	D
20-6		▲	●		3		3						70	145	215	290	D
20-7	△	▲	●		8		8						80	110	250	280	A(B,C,F,G); I(all others)
20-8	△	▲	●	○	6		4		2				80	110	250	280	I
20-11	△	▲	●		13		13						-	-	-	-	I
20-14	△	▲			5			3	2				80	110	250	280	A
20-15	△	▲	●		7			7					80	-	-	280	A
20-16	△	▲	●		9		7	2					80	110	250	280	A
20-17	△	▲	●		6		1	5					90	180	270	-	A
20-18	△	▲	●		9		6	3					35	110	250	325	A
20-19	△	▲	●		3				3				90	180	270	-	A
20-22	△	▲	●		6		3		3				80	110	250	280	A
20-23	△	▲	●		2				2				35	110	250	325	A
20-24	△	▲	●		4		2		2				35	110	250	325	A
20-25		▲	●		13		13						20-11 100°				I
20-27	△	▲	●		14		14						35	110	250	325	A
20-29	△	▲	●		17		17						80	-	-	280	A
20-30		▲	●		13		13						20-11 250°				I
20-32		▲	●		8		8						20-7 260°				A(B,C,F,G); I(all others)
20-33	△	▲	●		11		11						-	-	-	280	A
20-52		▲	●		4			4				T	20-4 315° A=IR.; B=CON.; C=CH.; D=AL.				
20-56		▲	●		8		8					T	20-7 45° A, B, G, H=IR.; C, D, E, F=CON.				
20-60		▲	●		8		8					T	20-7 45° D=CH.; E=AL.; BALANCE=CU				
20-61		▲	●		17		17					T	20-29 45° A, B, M=CU; BALANCE=CON.				
20-62		▲	●		7			7				T	20-15 80° A, C, E=AL.; B, D, F=CH.; G=CU				
20-64		▲	●		14		14					T	20-27 A=AL.; C=CH.; BALANCE=CU				
20-65		▲	●		14		14					T	20-27 A, B, C, D, E, F, G=IR.; H, I, J, K, L, M, N=CON.				
20-67		▲	●		9		7	2				T	20-16 H=AL.; I=CH.; BALANCE=CU				
20-68		▲	●		8		8					T	20-7 A, B, G, H=CON.; C, D, E, F=CU				
20-69		▲	●		14		14					T	20-27 A, B, C, D, E, F, G=CU; H, I, J, K, L, M, N=CON.				
20-70		▲	●		17		17					T	20-29 A, C, E, G, J, L, N, R, T=IR.; B, D, F, H, K, M, P, S=CON.				
20-71		▲	●		17		17					T	20-29 S=AL.; R=CH.; BALANCE=CU				
20-74		▲	●		17		17					T	20-29 A, C, E, G, J, L, N, R=IR.; B, D, F, H, K, M, P, S=CON.; T=CU				
20-75		▲	●		7			7				T	20-15 G=AL.; BALANCE=CH.				
20-77		▲	●		9		7	2				T	20-16 A=CON.; BALANCE=CU				
20-80		▲	●		14		14					T	20-27 A, C, E, G, I, K, M=CU; B, D, F, H, J, L, N=CON.				
20-81		▲	●		14		14					T	20-27 A, C, E, G, I, K, M=CU; B, D, F, H, J, L, N=AL.				
20-82		▲	●		17		17					T	20-29 A, C, E, G, J, L, N, R=AL.; B, D, F, H, K, M, P, S=CH.; T=CU				
20A9		▲	●	○	9			9					-	110	250	-	D(J); (all others)
20A16		▲	●		13		13						20-11 182°				I
20A37		▲	●		4			4					20-4 250°				D

ITT CANNON CA-B / CB SERIES BAYONET CONNECTORS



LAYOUTS BY SHELL SIZE

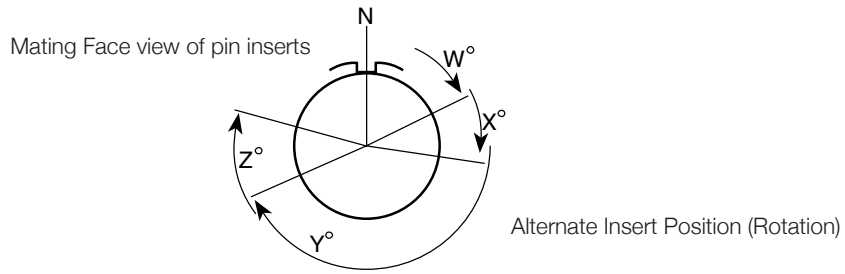

CONTACT METALLURGY KEY: **ALUMEL (AL.)** **CHROMEL (CH.)** **CONSTANTAN (CON.)** **COPPER (CU)** **IRON (IR.)** **THERMOCOUPLE (T)**

LAYOUT	SERIES				TOTAL	CONTACT SIZES						T	DEGREES OF ROTATION				SERVICE RATING
	MS	CT	CB	VG		20	16	12	8	4	0		W	X	Y	Z	
20A48			●	○	19		19						-	80	280	-	I
22-1		▲	●		2				2				35	110	250	325	D
22-2	△	▲	●	○	3				3				70	145	215	290	D
22-4	△	▲	●		4			2	2				35	110	250	325	A
22-5	△	▲	●		6		4	2					35	110	250	325	D
22-6	△	▲			3		1		2				80	110	250	280	D
22-7	△	▲	●		1						1		-	-	-	-	E
22-8	△	▲	●		2			2					35	110	250	325	E
22-9	△	▲	●		3			3					70	145	215	290	E
22-10	△	▲	●		4		4						35	110	250	325	E
22-11	△	▲			2		2						35	110	250	325	B
22-12	△	▲	●	○	5		3		2				80	110	250	280	A
22-13	△	▲			5		1	4					35	110	250	325	A(A-D); D(E)
22-14	△	▲	●	○	19		19						80	-	-	280	A
22-15	△	▲	●		6		1	5					80	110	250	280	A(A-C, E, F); E(D)
22-16		▲	●		9		6	3					80	110	250	280	A
22-17	△	▲			9		8	1					80	110	250	280	D(A); A(all others)
22-18	△	▲			8		8						80	110	250	280	A(C-E); D(all others)
22-19	△	▲	●		14		14						80	110	250	280	A
22-20	△	▲	●		9		9						35	110	250	325	A
22-21			●		3		2				1		80	110	250	280	A
22-22	△	▲	●	○	4				4				-	110	250	-	A
22-23	△	▲	●		8			8					35	-	250	-	D(H); A(all others)
22-27	△	▲	●	○	9		8		1				80	-	250	280	D(J); A(all others)
22-28	△	▲	●		7			7					80	-	-	280	A
22-30		▲	●		19		19						22-14 100°				A
22-31	△	▲			2		2						22-11 100°				B
22-32		▲	●		6		4	2					22-5 260°				D
22-57		▲	●		19		19					T	22-14 45° A, C, E, G, J, L, N, R=IR.; B, D, F, H, K, M, P, S=CON.; T, U, V=CU				
22-60		▲	●		19		19						22-14 45° U=AL.; N=CH.; BALANCE=CU				
22-62		▲	●		8			8				T	22-23 60° A, B, F, G=AL.; C, D, E, H=CH.				
22-68		▲	●		14		14					T	22-19 45° A, C, E, G, J, L, M=IR.; B, D, F, H, K, P, N=CON.				
22-69		▲	●		14		14					T	22-19 45° A, C, E, G, J, L, M=CU; B, D, F, H, K, P, N=CON.				
22-71		▲	●		19		19					T	22-14 V=AL.; U=CH.; BALANCE=CU				
22-72		▲	●		6		4	2				T	22-5 B=AL.; E=CH.; BALANCE=CU				

LAYOUTS BY SHELL SIZE

CONTACT METALLURGY KEY: **ALUMEL (AL.) CHROMEL (CH.) CONSTANTAN (CON.) COPPER (CU) IRON (IR.) THERMOCOUPLE (T)**

LAYOUT	SERIES				TOTAL	CONTACT SIZES						T	DEGREE OF ROTATION				SERVICE RATING
	MS	CT	CB	VG		20	16	12	8	4	0		W	X	Y	Z	
22-73		▲	●		6		4	2				⌋	22-5 E=AL.; B=CH.; BALANCE=CU				
22-74		▲	●		8			8				⌋	22-23 A, C, E, G=IR.; B, D, F, H=CON.				
22-75		▲	●		8			8				⌋	22-23 A=AL.; B, D, G, H=CU; C=CH.; E=IR.; F=CON.				
22-77		▲	●		14		14					⌋	22-19 B, D, F, H, J, K, M, P=CU; A, E, L=IR.; C, G, N=CON.				
22-78		▲	●		19		19					⌋	22-14 A, C, E, G, H, K, M, P, R, T=CON.; BALANCE=CU				
22-79		▲	●		4		4					⌋	22-10 A, C, =CON.; B, D=CU				
24-2	△	▲	●		7			7					80	-	-	280	D
24-5	△	▲	●		16		16						80	110	250	280	A
24-6	△	▲			8			8					80	110	250	280	D(A,G,H); A(all others)
24-7	△	▲	●		16		14	2					80	110	250	280	A
24-9	△	▲	●		2					2			35	110	250	325	A
24-10	△	▲	●	○	7				7				80	-	-	280	A
24-11	△	▲	●	○	9			6	3				35	110	250	325	A
24-12	△	▲	●	○	5			3		2			80	110	250	280	A
24-15		▲	●		16		16						24-5 100°				A
24-19		▲	●		12		12						-	-	-	-	A
24-20	△	▲	●		11		9	2					80	110	250	280	D
24-22	△	▲	●		4				4				45	110	250	-	D
24-24		▲	●		16		16						24-5 250°				A
24-25		▲	●		8			8					24-6 100°				D(A,G,H); A(all others)
24-26		▲	●		8			8					24-6 250°				D(A,G,H); A(all others)
24-27	△	▲	●		7		7						80	-	-	280	E
24-28	△	▲	●		24		24						80	110	250	280	I
24-56		▲	●		11		9	2				⌋	24-20 45° E=AL.; F=CH.; BALANCE=CU				
24-57		▲	●		24		24					⌋	24-28 45° A, C, J, V, Y, W, K, E, H, U, S, M=CH.; BALANCE=AL.				
24-62		▲	●		24		24					⌋	24-28 A, C, E, G=IR.; B, D, F, H=CON.; R, T=CH.; S, U=AL.; BALANCE=CU				
24-63		▲	●		24		24					⌋	24-28 A, C, E, G, J, L, K, N, S, U, W, Y=CU; B, D, F, H, Q, R, M, P, T, V, X, Z=CON.				
24-64		▲	●		16		16					⌋	24-5 A, B, C, D, E, F, G, H=IR.; J, K, L, M, N, P, R, S=CON.				
24-68		▲	●		24		24					⌋	24-28 D=CON.; BALANCE=CU				
24-79					5				5				-	-	-	-	A
24-81		▲	●		16		14	2				⌋	24-7 A, C, E, G, I, K, M, N, P=CU; B, D, F, H, J, L, O=CON.				
24A24		▲	●		12			12					CONTACT FOR VALID ROTATIONS				A
24A28			●		28		28						65	146	235	-	I
24A35		▲	●		16		14	2					24-7 100°				A
28-1	△	▲			9			6	3				80	110	250	280	D(A, E, J); A(all others)
28-2	△	▲	●		14		12	2					35	110	250	325	D
28-4		▲			9		7	2					80	110	250	280	E(G,P,S); D(all others)
28-5		▲	●		5		2	1		2			35	110	250	325	D
28-7		▲			2					2			35	110	250	325	D
28-9	△	▲	●		12		6	6					80	110	250	280	D
22B22			●		4				4				-	110	250	-	A

LAYOUTS BY SHELL SIZE

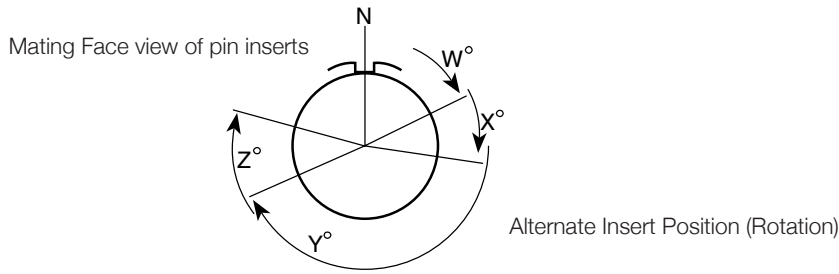

CONTACT METALLURGY KEY: **ALUMEL (AL.)** **CHROMEL (CH.)** **CONSTANTAN (CON.)** **COPPER (CU)** **IRON (IR.)** **THERMOCOUPLE (⌘)**

LAYOUT	SERIES				TOTAL	CONTACT SIZES						⌘	DEGREES OF ROTATION				SERVICE RATING
	MS	CT	CB	VG		20	16	12	8	4	0		W	X	Y	Z	
28-10	△	▲	●		7			3	2	2			80	110	250	280	D(G); A(all others)
28-11	△	▲	●	○	22		18	4					80	110	250	280	A
28-12	△	▲	●		26		26						90	180	270	-	A
28-13		▲	●		26		26						28-12 100°				A
28-14		▲			11		11						80	110	250	280	D
28-15	△	▲	●		35		35						80	110	250	280	A
28-16	△	▲	●		20		20						80	110	250	280	A
28-17	△	▲			15		15						80	110	250	280	A(A-L); B(R); D(M-P)
28-19	△	▲	●		10		6	4					80	110	250	280	A(C, E, G, J, K, L); B(H, M); D(A, B)
28-20	△	▲	●	○	14		4	10					80	110	250	280	A
28-21	△	▲	●	○	37		37						80	110	250	280	A
28-22	△	▲	●		6		3			3			70	145	215	290	D
28-51		▲	●		12			12					80	135	195	-	A
28-53		▲	●		22		18	4				⌘	28-11 45° J, L=AL.; K, M=CH.; BALANCE=CU				
28-58		▲	●		14		4	10				⌘	28-20 45° A, C, E, G, K, M=AL.; B, D, F, H, L, N=CH.; J, P=CU				
28-59		▲			17		10	7					-	-	-	-	A
28-61		▲	●		37		37					⌘	28-21 45° A, C, J, Z, M, R, N, A, K, F, H, X, K, H, T, M, N, D=IR.; BALANCE=CON.				
28-63		▲	●	○	14		4	10				⌘	28-20 45° A, C, E, G, J=AL.; B, D, F, H, P=CH.; BALANCE=CU				
28-64		▲	●		35		35					⌘	28-15 A, D=AL.; B, J=CH.; C, D, E, F, G, N, P, R, S, H, J, K, L, M, W, X, Y, Z=CON.; BALANCE=CU				
28-65		▲	●		26		26					⌘	28-12 A, C, E, G, J, L, N, R, T, V=IR.; X, Z=AL.; B, D, F, H, K, M, P, S, U, W=CON.; Y, A=CH.; B, D=CU				
28-67		▲	●		20		20					⌘	28-16 U=CON.; BALANCE=CU				
28-68		▲	●		35		35					⌘	28-15 45° T=AL.; U=CH.; BALANCE=CU				
28-69		▲	●		22		18	4				⌘	28-11 G=AL.; R=CH.; BALANCE=CU				
28-70		▲	●		22		18	4				⌘	28-11 A=AL.; B=CH.; BALANCE=CU				
28-77		▲	●		22		18	4				⌘	28-11 J=CON.; BALANCE=CU				
28-81		▲	●		37		37					⌘	28-21 A, D, S, Z, N, S=IR.; B, J, K, F, G, R=CON.; G, L, P, B, E, J=AL.; F, H, T, X, H, K=CH.; BALANCE=CU				
28A16		▲	●		9		5			4			CONTACT US FOR VALID ROTATION				A(E); I(all others)
28A51		▲	●		43		43						CONTACT US FOR VALID ROTATION				A
28A63			●		28		19	9					-	110	260	-	A
32-1	△	▲	●		5			3			2		80	110	250	280	E(A); D(all others)
32-2		▲			5		2			3			70	145	215	290	E

LAYOUTS BY SHELL SIZE

CONTACT METALLURGY KEY: **ALUMEL (AL.)** **CHROMEL (CH.)** **CONSTANTAN (CON.)** **COPPER (CU)** **IRON (IR.)** **THERMOCOUPLE (T)**

LAYOUT	SERIES				TOTAL	CONTACT SIZES						T	DEGREE OF ROTATION				SERVICE RATING
	MS	CT	CB	VG		20	16	12	8	4	0		W	X	Y	Z	
32-5		▲	●		2						2		35	110	250	325	D
32-6	△	▲	●	○	23		16	2	3	2			80	110	250	280	A
32-7	△	▲	●	○	35		28	7					80	125	235	280	I(A,B,H,J); A(all others)
32-8	△	▲	●		30		24	6					80	125	235	280	A
32-9	△	▲	●		14		12			2			80	110	250	280	D
32-13	△	▲	●		23		18	5					80	110	250	280	D
32-15	△	▲	●		8			6			2		35	110	250	280	D
32-17	△	▲	●		4					4			45	110	250	-	D
32-19		▲	●		5			3			2		32-1 260°				E(A); D(all others)
32-20		▲	●		23		16	2	3	2			32-6 260°				A
32-51		▲	●		30		24	6				T	32-8 90° M=CH.; N= AL.; BALANCE=CU				
32-55		▲	●		30		24	6				T	32-8 125° M, N=CH.; O, P=AL.; BALANCE=CU				
32A10		▲	●		54		54						CONTACT US FOR VALID ROTATION				A
32A29		▲	●		23		16	2	3	2			32-6 250°				A
32A30		▲	●		5			3		2			32-1 100°				E(A); D(all others)
32A47		▲	●		47		47						CONTACT US FOR VALID ROTATION				A
32A55			●		55		55						80	110	250	280	A
32A69			●	○	61	41	20						-	110	250	-	I
36-3		▲	●		6			3			3		70	145	215	290	D
36-4	△	▲			3						3		70	145	215	290	A(B,C); D(A)
36-5	△	▲	●	○	4						4		45	120	240	-	A
36-6	△	▲	●	○	6					4	2		35	110	250	325	A
36-7	△	▲	●		47		40	7					80	110	250	280	A
36-8	△	▲	●		47		46	1					80	110	250	280	A
36-9	△	▲	●		31		14	14	2	1			80	125	235	280	A
36-10	△	▲	●	○	48		48						80	125	235	280	A
36-11		▲	●		48		48						36-10 100°				A
36-12		▲	●		48		48						36-10 250°				A
36-14	△	▲	●		16		6	5	5				90	180	270	-	D
36-15	△	▲	●		35		35						60	125	245	305	D(m); A(all others)
36-16		▲	●		47		40	7					36-7 100°				
36-17		▲	●		47		40	7					36-7 250°				A
36-18		▲	●		31		14	14	2	1			36-9 100°				A
36-21		▲	●		31		14	14	2	1			36-9 260°				A
36-53		▲	●		47		40	7				T	36-7 45° U, V, W=AL.; X, Y, Z=CH.; BALANCE=CU				
36A34		▲	●		52		52						CONTACT US FOR VALID ROTATION				A
36A35		▲	●		8		4				4		CONTACT US FOR VALID ROTATION				A
36A46		▲	●		27			27					CONTACT US FOR VALID ROTATION				A
36A98		▲	●		39		31		8				CONTACT US FOR VALID ROTATION				I
36A99			●		65	50	15						CONTACT US FOR VALID ROTATION				I
36A70		▲			16		5			11			-	-	-	-	I

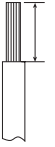
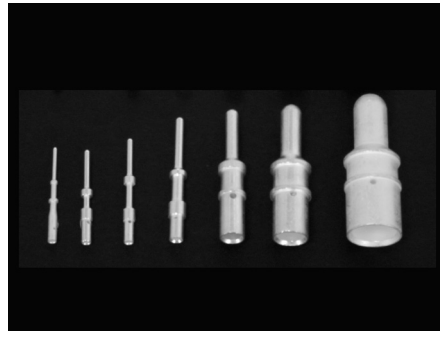

CONTACT SIZE		CB CRIMP PINS			CB CRIMP SOCKETS			WIRE STRIP LENGTHS
CONTACT SIZE	WIRE GAUGE (AWG)	PART NUMBER			PART NUMBER			
		SILVER	GOLD		SILVER	GOLD		
16S	16-18*	CB16S-16P*	CB16S-16PG*	-	CB16S-16S*	CB16S-16SG*	-	
	20-22	CB16S-20P	CB16S-20PG	G5	CB16S-20S	CB16S-20SG	G5	
	22-26	CB16S-22P	CB16S-22PG	G6	CB16S-22S	CB16S-22SG	G6	
16	12-14	CB16-12P	CB16-12PG	G13	CB16-12S	CB16-12SG	G13	
	14-16	CB16-14P	CB16-14PG	G12	CB16-14S	CB16-14SG	G12	
	16-18*	CB16-16P*	CB16-16PG*	-	CB16-16S*	CB16-16SG*	-	
	20-22	CB16-20P	CB16-20PG	G9	CB16-20S	CB16-20SG	G9	
	22-26	CB16-22P	CB16-22PG	G10	CB16-22S	CB16-22SG	G10	
12	12-14*	CB12-12P*	CB12-12PG*	-	CB12-12S*	CB12-12SG*	-	
	16-18	CB12-16P	CB12-16PG	G16	CB12-16S	CB12-16SG	G16	
8	8-10*	CB8-8P*	-	-	CB8-8S*	-	-	
	10	CB8-10P	-	G42	CB8-10S	-	G42	
	12-14	CB8-12P	-	G40	CB8-12S	-	G40	
4	4*	CB4-4P*	-	-	CB4-4S*	-	-	
	6	CB4-6P	-	G44	CB4-6S	-	G44	
0	0*	CB0-0P*	-	-	CB0-0S*	-	-	
	2	CB0-2P	-	G48	CB0-2S	-	G48	
	4	CB0-4P	-	G47	CB0-4S	-	G47	

Part Numbers marked with \* are the standard for that contact size  
 All dimensions are shown in inches (millimeters in parentheses)

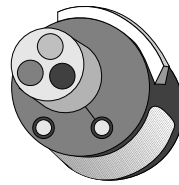
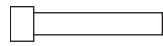

CONTACT SIZE	WIRE RANGE		ACCESSORIES					TOOLS				
	INSULATION O.D. MIN	INSULATION O.D. MAX	WIRE HOLE FILLERS	HOLE FILLER COLOR	HAND CRIMP TOOL	HAND TOOL TURRET	USE LOCATOR COLOR	POWER CRIMP TOOL	POWER CRIMP LOCATOR	INSERTION/ EXTRACTION TOOL	INSERTION GUIDE PINS	
16S	.089 (2.2)	.110 (2.8)	225-0017-000	BLUE	AF8	TH452	BLUE△/GREEN◆	400BHD Shown 400BHD	WA27F	USE HAND TOOL TURRET WITH POWER TOOL	CIT-F80-16* CET-F80-16†	226-1017-000
16	.089 (2.2)	.110 (2.8)	225-0017-000	BLUE	AF8	TH452	GREEN△/RED◆					
12	.122 (3.1)	.138 (3.5)	225-0018-000	YELLOW	AF8	TH452	RED					
8	.220 (5.6)	.256 (6.5)	MS27488-8-3	RED	-	-	-	400BHD	CCH8-KIT	CIT-8* CET-8†	-	
4	.335 (8.5)	.370 (9.4)	MS27488-4-3	BLUE	-	-	-		CCH4-KIT	CIT-4* CET-4†	-	
0	.452 (11.5)	.512 (13.0)	MS27488-0-3	YELLOW	-	-	-		CCH0-KIT	CIT-0* CET-0†	-	

\*Insertion Tool †Extraction Tool △ Pin ◆ Socket  
All dimensions are shown in inches (millimeters in parentheses)



**CRIMP KITS ARE AVAILABLE FOR 16S & 16 SIZE CONTACTS - CAB16KIT. KIT INCLUDES**

- Crimp tool
- Locator
- Insertion tool
- Insertion guide pins
- Extraction tool
- Assembly instructions
- Rugged case

COMPONENTS

	RECEPTACLE	PLUG
O-RING		
BARREL/SHELL		
INSERT/ INSULATOR		
CONTACTS		
WAVE SPRING AND SKID WASHER (OPTIONAL)		
COUPLING NUT		
INDIVIDUAL WIRE SEALING GROMMET		
FERRULE/SLEEVE COMPRESSION RING		
ENDBELL/ BACKSHELL/ CABLE CLAMP & BUSHING		



CB 2 STYLES

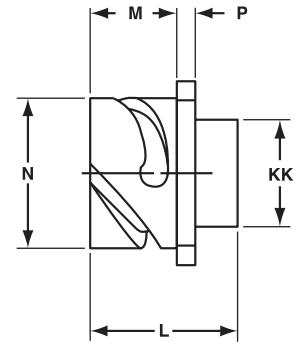
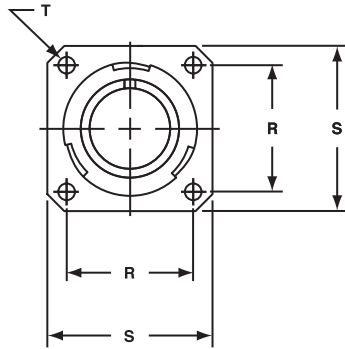

SHELL SIZE	M +.016(0.40)		N -.006(0.15)		P (MAX.)		R ±.004(0.10)		S +.016(0.40)		T		L ±.012(0.30)		KK (MAX.)	
	IN	MM	IN	MM	IN	MM	IN	MM	IN	MM	IN	MM	IN	MM	IN	MM
10SL	0.717	(18.2)	0.717	(18.2)	0.11	(2.8)	0.717	(18.2)	1	(25.4)	0.126	(3.2)	0.972	(24.7)	0.638	(16.2)
12S	0.717	(18.2)	0.843	(21.4)	0.126	(3.2)	0.811	(20.6)	1.102	(28.0)	0.126	(3.2)	0.972	(24.7)	0.638	(16.2)
14S	0.717	(18.2)	0.969	(24.6)	0.126	(3.2)	0.906	(23.0)	1.181	(30.0)	0.126	(3.2)	0.972	(24.7)	0.756	(19.2)
16S	0.717	(18.2)	1.079	(27.4)	0.126	(3.2)	0.969	(24.6)	1.280	(32.5)	0.126	(3.2)	0.972	(24.7)	0.882	(22.4)
16	0.846	(21.5)	1.079	(27.4)	0.126	(3.2)	0.969	(24.6)	1.280	(32.5)	0.126	(3.2)	1.331	(33.8)	0.882	(22.4)
18	0.907	(23.1)	1.213	(30.8)	0.157	(4.0)	1.063	(27.0)	1.378	(35.0)	0.126	(3.2)	1.331	(33.8)	1.008	(25.6)
20	0.907	(23.1)	1.346	(34.2)	0.157	(4.0)	1.157	(29.4)	1.496	(38.0)	0.126	(3.2)	1.331	(33.8)	1.142	(29.0)
22	0.907	(23.1)	1.472	(37.4)	0.157	(4.0)	1.252	(31.8)	1.614	(41.0)	0.126	(3.2)	1.331	(33.8)	1.268	(32.2)
24	0.907	(23.1)	1.610	(40.9)	0.157	(4.0)	1.374	(34.9)	1.752	(44.5)	0.146	(3.7)	1.331	(33.8)	1.390	(35.3)
28	0.947	(24.1)	1.839	(46.7)	0.157	(4.0)	1.563	(39.7)	2.000	(50.8)	0.146	(3.7)	1.331	(33.8)	1.630	(41.4)
32	0.947	(24.1)	2.102	(53.4)	0.157	(4.0)	1.752	(44.5)	2.244	(57.0)	0.169	(4.3)	1.331	(33.8)	1.882	(47.8)
36	0.947	(24.1)	2.346	(59.6)	0.157	(4.0)	1.937	(49.2)	2.500	(63.5)	0.169	(4.3)	1.331	(33.8)	2.071	(52.6)

CB 0 STYLES

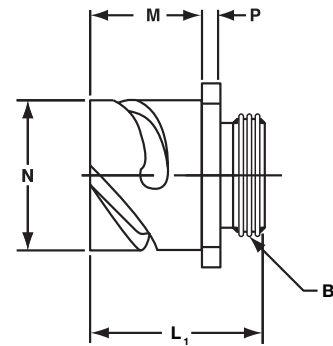
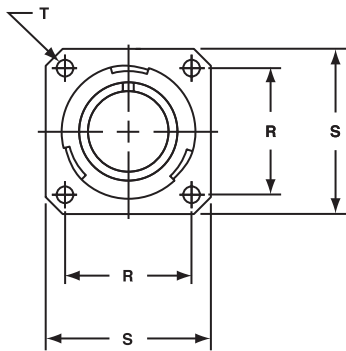

SHELL SIZE	M +.016(0.40)		N -.006(0.15)		P (MAX.)		R ±.006(0.10)		S ±.016(0.40)		T		L <sub>1</sub> ±.012(.30)		B <sub>1</sub> THREAD 2A
	IN	MM	IN	MM	IN	MM	IN	MM	IN	MM	IN	MM	IN	MM	
10SL	0.717	(18.2)	0.717	(18.2)	0.110	(2.8)	0.717	(18.2)	1.000	(25.4)	0.126	(3.2)	1.276	(32.4)	9/16-24UNEF
12S	0.717	(18.2)	0.843	(21.4)	0.126	(3.2)	0.811	(20.6)	1.102	(28.0)	0.126	(3.2)	1.276	(32.4)	5/8-24UNEF
14S	0.717	(18.2)	0.969	(24.6)	0.126	(3.2)	0.906	(23.0)	1.181	(30.0)	0.126	(3.2)	1.276	(32.4)	3/4-20UNEF
16S	0.717	(18.2)	1.079	(27.4)	0.126	(3.2)	0.969	(24.6)	1.280	(32.5)	0.126	(3.2)	1.276	(32.4)	7/8-20UNEF
16	0.907	(23.05)	1.079	(27.4)	0.126	(3.2)	0.969	(24.6)	1.280	(32.5)	0.126	(3.2)	1.575	(40.0)	7/8-20UNEF
18	0.907	(23.05)	1.213	(30.8)	0.157	(4.0)	1.063	(27.0)	1.378	(35.0)	0.126	(3.2)	1.634	(41.5)	1-20UNEF
20	0.907	(23.05)	1.346	(34.2)	0.157	(4.0)	1.157	(29.4)	1.496	(38.0)	0.126	(3.2)	1.634	(41.5)	1-1/8-18UNEF
22	0.907	(23.05)	1.472	(37.4)	0.157	(4.0)	1.252	(31.8)	1.614	(41.0)	0.126	(3.2)	1.634	(41.5)	1-1/4-18UNEF
24	0.907	(23.05)	1.610	(40.9)	0.157	(4.0)	1.374	(34.9)	1.752	(44.5)	0.146	(3.7)	1.634	(41.5)	1-3/8-18UNEF
28	0.947	(24.05)	1.839	(46.7)	0.157	(4.0)	1.563	(39.7)	2.000	(50.8)	0.146	(3.7)	1.673	(42.5)	1-5/8-18UNEF
32	0.947	(24.05)	2.102	(53.4)	0.157	(4.0)	1.752	(44.5)	2.244	(57.0)	0.169	(4.3)	1.673	(42.5)	1-7/8-16UN
36	0.947	(24.05)	2.346	(59.6)	0.157	(4.0)	1.937	(49.2)	2.500	(63.5)	0.169	(4.3)	1.673	(42.5)	2-1/8-16UN

CB 0 ENDBELL STYLES

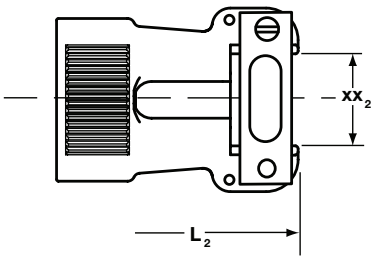

E

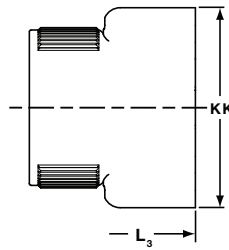

R

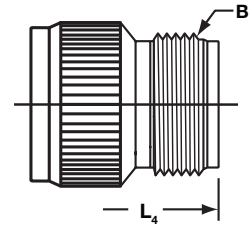

F

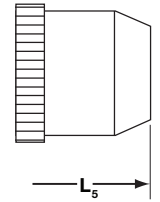

P

SHELL SIZE	L <sub>2</sub> MAX		XX <sub>2</sub> MAX		XX <sub>2</sub> MIN	
	IN	MM	IN	MM	IN	MM
10SL	2.244	(57.0)	0.256	(6.5)	0.140	(3.6)
12S	2.244	(57.0)	0.256	(6.5)	0.140	(3.6)
14S	2.323	(59.0)	0.354	(9.0)	0.195	(5.0)
16S	2.362	(60.0)	0.433	(11.0)	0.255	(6.5)
16	2.677	(68.0)	0.433	(11.0)	0.255	(6.5)
18	2.835	(72.0)	0.559	(14.2)	0.285	(7.2)
20	2.835	(72.0)	0.622	(15.8)	0.350	(8.9)
22	2.835	(72.0)	0.622	(15.8)	0.350	(8.9)
24	3.071	(78.0)	0.843	(21.4)	0.468	(11.9)
28	3.110	(79.0)	0.843	(21.4)	0.468	(11.9)
32	3.071	(78.0)	1.051	(26.7)	0.664	(16.9)
36	3.071	(78.0)	1.248	(31.7)	0.694	(17.6)

L <sub>3</sub> MAX		KK	
IN	MM	IN	MM
1.969	(50.0)	0.378	(9.6)
2.047	(52.0)	0.406	(10.3)
2.047	(52.0)	0.488	(12.4)
2.283	(58.0)	0.606	(15.4)
2.283	(58.0)	0.606	(15.4)
2.559	(65.0)	0.724	(18.4)
2.559	(65.0)	0.866	(22.0)
2.559	(65.0)	0.972	(24.7)
2.638	(67.0)	1.087	(27.6)
2.638	(67.0)	1.244	(31.6)
2.638	(67.0)	1.516	(38.5)
2.638	(67.0)	1.752	(44.5)

L <sub>4</sub> MAX		B <sub>2</sub> THREAD 2A	L <sub>5</sub> MAX	
IN	MM		IN	MM
2.047	(52.0)	5/8-24UNEF	1.531	(38.9)
2.047	(52.0)	5/8-24UNEF	1.531	(38.9)
2.047	(52.0)	3/4-20UNEF	1.531	(38.9)
2.323	(59.0)	7/8-20UNEF	1.531	(38.9)
2.323	(59.0)	7/8-20UNEF	1.968	(50.0)
2.480	(63.0)	1-20UNEF	1.968	(50.0)
2.480	(63.0)	1-3/16-18UNEF	2.188	(55.6)
2.598	(66.0)	1-3/16-18UNEF	2.188	(55.6)
2.717	(69.0)	1-7/16-18UNEF	2.188	(55.6)
2.756	(70.0)	1-7/16-18UNEF	2.188	(55.6)
2.795	(71.0)	1-3/4-18NS	2.188	(55.6)
2.874	(73.0)	2-18NS	2.188	(55.6)

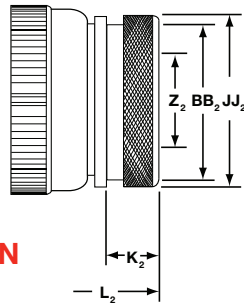

N

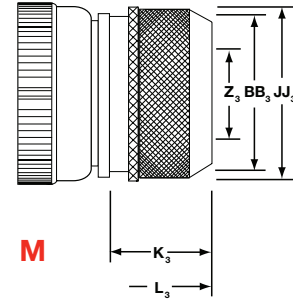

M

SHELL SIZE	L <sub>2</sub> MAX		K <sub>2</sub> MAX		Z <sub>2</sub> MIN		BB <sub>2</sub> MAX		JJ <sub>2</sub> ±.008(0.20)	
	IN	MM	IN	MM	IN	MM	IN	MM	IN	MM
10SL	2.244	(57.0)	0.461	(11.7)	0.303	(7.7)	0.524	(13.3)	0.610	(15.5)
12S	2.244	(57.0)	0.461	(11.7)	0.311	(7.9)	0.524	(13.3)	0.610	(15.5)
14S	2.244	(57.0)	0.461	(11.7)	0.417	(10.6)	0.669	(17.0)	0.752	(19.1)
16S	2.244	(57.0)	0.461	(11.7)	0.531	(13.5)	0.862	(21.9)	0.941	(23.9)
16	2.480	(63.0)	0.453	(11.5)	0.531	(13.5)	0.862	(21.9)	0.941	(23.9)
18	2.559	(65.0)	0.453	(11.5)	0.575	(14.6)	0.862	(21.9)	0.941	(23.9)
20	2.677	(68.0)	0.500	(12.7)	0.736	(18.7)	1.031	(26.2)	1.165	(29.6)
22	2.677	(68.0)	0.500	(12.7)	0.819	(20.8)	1.031	(26.2)	1.165	(29.6)
24	2.756	(70.0)	0.500	(12.7)	0.969	(24.6)	1.358	(34.5)	1.488	(37.8)
28	2.795	(71.0)	0.500	(12.7)	1.063	(27.0)	1.358	(34.5)	1.488	(37.8)
32	2.913	(74.0)	0.598	(15.2)	1.311	(33.3)	1.717	(43.6)	1.882	(47.8)
36	2.913	(74.0)	0.598	(15.2)	1.516	(38.5)	1.717	(43.6)	1.882	(47.8)

L <sub>3</sub> MAX		K <sub>3</sub> MAX		Z <sub>3</sub> MIN		BB <sub>3</sub> MAX		JJ <sub>3</sub> ±.008(0.20)	
IN	MM	IN	MM	IN	MM	IN	MM	IN	MM
2.165	(55.0)	0.669	(17.0)	0.303	(7.7)	0.642	(16.3)	0.728	(18.5)
2.283	(58.0)	0.669	(17.0)	0.366	(9.3)	0.669	(17.0)	0.787	(20.0)
2.283	(58.0)	0.669	(17.0)	0.417	(10.6)	0.787	(20.0)	0.866	(22.0)
2.756	(70.0)	0.709	(18.0)	0.531	(13.5)	0.906	(23.0)	0.984	(25.0)
2.756	(70.0)	0.709	(18.0)	0.531	(13.5)	0.906	(23.0)	0.984	(25.0)
2.756	(70.0)	0.709	(18.0)	0.575	(14.6)	0.965	(24.5)	1.102	(28.0)
2.756	(70.0)	0.709	(18.0)	0.728	(18.5)	1.122	(28.5)	1.260	(32.0)
2.756	(70.0)	0.709	(18.0)	0.819	(20.8)	1.201	(30.5)	1.339	(34.0)
2.756	(70.0)	0.709	(18.0)	0.969	(24.6)	1.358	(34.5)	1.496	(38.0)
2.756	(70.0)	0.709	(18.0)	1.063	(27.0)	1.476	(37.5)	1.614	(41.0)
2.953	(75.0)	0.709	(18.0)	1.311	(33.3)	1.732	(44.0)	1.890	(48.0)
3.346	(85.0)	0.709	(18.0)	1.516	(38.5)	2.008	(51.0)	2.165	(55.0)

CB 1 STYLES

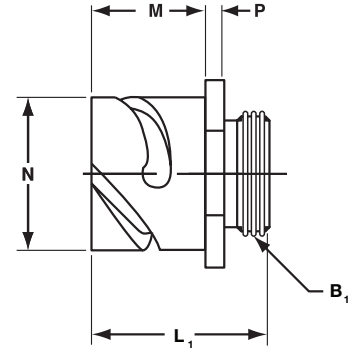
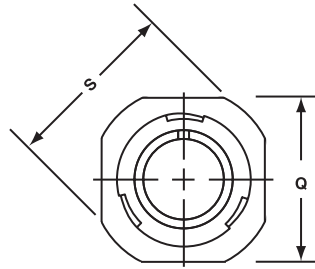

SHELL SIZE	M ±.016(0.40)		N -.006(0.15)		P ±.008(0.20)		Q MAX		S	
	IN	MM	IN	MM	IN	MM	IN	MM	IN	MM
10SL	0.717	(18.2)	0.717	(18.2)	0.110	(2.8)	0.811	(20.6)	0.992	(25.2)
12S	0.843	(21.4)	0.843	(21.4)	0.126	(3.2)	0.929	(23.6)	1.094	(27.8)
14S	0.969	(24.6)	0.969	(24.6)	0.126	(3.2)	1.000	(25.4)	1.173	(29.8)
16S	1.079	(27.4)	1.079	(27.4)	0.126	(3.2)	1.126	(28.6)	1.272	(32.3)
16	1.079	(27.4)	1.079	(27.4)	0.126	(3.2)	1.126	(28.6)	1.272	(32.3)
18	1.213	(30.8)	1.213	(30.8)	0.157	(4.0)	1.248	(31.7)	1.370	(34.8)
20	1.346	(34.2)	1.346	(34.2)	0.157	(4.0)	1.374	(34.9)	1.488	(37.8)
22	1.472	(37.4)	1.472	(37.4)	0.157	(4.0)	1.500	(38.1)	1.618	(41.1)
24	1.61	(40.9)	1.610	(40.9)	0.157	(4.0)	1.626	(41.3)	1.756	(44.6)
28	1.839	(46.7)	1.839	(46.7)	0.157	(4.0)	1.874	(47.6)	2.004	(50.9)
32	2.102	(53.4)	2.102	(53.4)	0.157	(4.0)	2.126	(54.0)	2.248	(57.1)
36	2.346	(59.6)	2.346	(59.6)	0.157	(4.0)	2.386	(60.6)	2.504	(63.6)

L <sub>1</sub>		B <sub>1</sub> THREAD 2A
IN	MM	
1.276	(32.4)	9/16-24UNEF
1.276	(32.4)	5/8-24UNEF
1.276	(32.4)	3/4-20UNEF
1.276	(32.4)	7/8-20UNEF
1.575	(40.0)	7/8-20UNEF
1.634	(41.5)	1-20UNEF
1.634	(41.5)	1-1/8-18UNEF
1.634	(41.5)	1-1/4-18UNEF
1.634	(41.5)	1-3/8-18UNEF
1.673	(42.5)	1-5/8-18UNEF
1.673	(42.5)	1-7/8-16UN
1.673	(42.5)	2-1/8-16UN

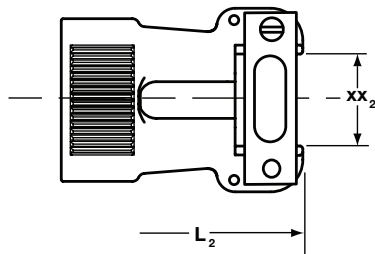

E

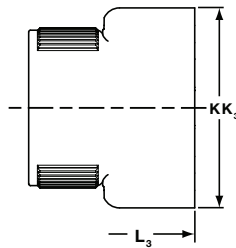

R

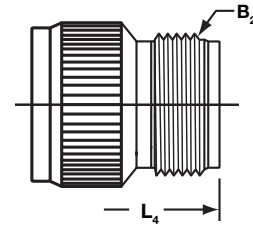

F

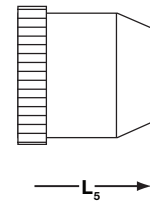

P

SHELL SIZE	L <sub>2</sub> MAX		XX <sub>2</sub> MAX		XX <sub>2</sub> MIN		L <sub>3</sub> MAX		KK <sub>3</sub>		L <sub>4</sub> MAX		B <sub>2</sub> THREAD 2A	L <sub>5</sub> MAX	
	IN	MM	IN	MM	IN	MM	IN	MM	IN	MM	IN	MM		IN	MM
10SL	2.244	(57.0)	0.256	(6.5)	0.140	(3.6)	1.969	(50.0)	0.378	(9.6)	2.047	(52.0)	5/8-24UNEF	1.531	(38.9)
12S	2.244	(57.0)	0.256	(6.5)	0.140	(3.6)	2.047	(52.0)	0.406	(10.3)	2.047	(52.0)	5/8-24UNEF	1.531	(38.9)
14S	2.323	(59.0)	0.354	(9.0)	0.195	(5.0)	2.047	(52.0)	0.488	(12.4)	2.047	(52.0)	3/4-20UNEF	1.531	(38.9)
16S	2.362	(60.0)	0.433	(11.0)	0.255	(6.5)	2.283	(58.0)	0.606	(15.4)	2.323	(59.0)	7/8-20UNEF	1.531	(38.9)
16	2.677	(68.0)	0.433	(11.0)	0.255	(6.5)	2.283	(58.0)	0.606	(15.4)	2.323	(59.0)	7/8-20UNEF	1.968	(50.0)
18	2.835	(72.0)	0.559	(14.2)	0.285	(7.2)	2.559	(65.0)	0.724	(18.4)	2.480	(63.0)	1-20UNEF	1.968	(50.0)
20	2.835	(72.0)	0.622	(15.8)	0.350	(8.9)	2.559	(65.0)	0.866	(22.0)	2.480	(63.0)	1-3/16-18UNEF	2.188	(55.6)
22	2.835	(72.0)	0.622	(15.8)	0.350	(8.9)	2.559	(65.0)	0.972	(24.7)	2.598	(66.0)	1-3/16-18UNEF	2.188	(55.6)
24	3.071	(78.0)	0.843	(21.4)	0.468	(11.9)	2.638	(67.0)	1.087	(27.6)	2.717	(69.0)	1-7/16-18UNEF	2.188	(55.6)
28	3.110	(79.0)	0.843	(21.4)	0.468	(11.9)	2.638	(67.0)	1.244	(31.6)	2.756	(70.0)	1-7/16-18UNEF	2.188	(55.6)
32	3.071	(78.0)	1.051	(26.7)	0.664	(16.9)	2.638	(67.0)	1.516	(38.5)	2.795	(71.0)	1-3/4-18NS	2.188	(55.6)
36	3.071	(78.0)	1.248	(31.7)	0.694	(17.6)	2.638	(67.0)	1.752	(44.5)	2.874	(73.0)	2-18NS	2.188	(55.6)

**CB 1 ENDBELL STYLES (CONTINUED)**

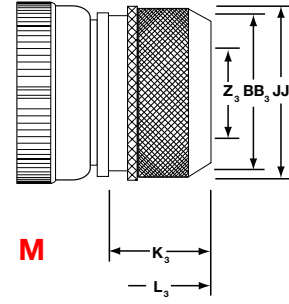
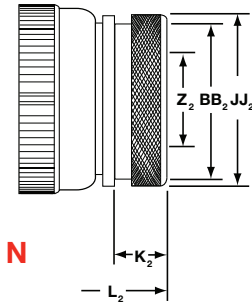

SHELL SIZE	L <sub>2</sub> MAX		K <sub>2</sub> MAX		Z <sub>2</sub> MIN		BB <sub>2</sub> MAX		JJ <sub>2</sub> ±.008(0.20)		L <sub>3</sub> MAX		K <sub>3</sub> MAX		Z <sub>3</sub> MIN		BB <sub>3</sub> MAX		JJ <sub>3</sub> ±.008(0.20)	
	IN	MM	IN	MM	IN	MM	IN	MM	IN	MM	IN	MM	IN	MM	IN	MM	IN	MM	IN	MM
10SL	2.244	(57.0)	0.461	(11.7)	0.303	(7.7)	0.524	(13.3)	0.610	(15.5)	2.165	(55.0)	0.669	(17.0)	0.303	(7.7)	0.642	(16.3)	0.728	(18.5)
12S	2.244	(57.0)	0.461	(11.7)	0.311	(7.9)	0.524	(13.3)	0.610	(15.5)	2.283	(58.0)	0.669	(17.0)	0.366	(9.3)	0.669	(17.0)	0.787	(20.0)
14S	2.244	(57.0)	0.461	(11.7)	0.417	(10.6)	0.669	(17.0)	0.752	(19.1)	2.283	(58.0)	0.669	(17.0)	0.417	(10.6)	0.787	(20.0)	0.866	(22.0)
16S	2.244	(57.0)	0.461	(11.7)	0.531	(13.5)	0.862	(21.9)	0.941	(23.9)	2.756	(70.0)	0.709	(18.0)	0.531	(13.5)	0.906	(23.0)	0.984	(25.0)
16	2.480	(63.0)	0.453	(11.5)	0.531	(13.5)	0.862	(21.9)	0.941	(23.9)	2.756	(70.0)	0.709	(18.0)	0.531	(13.5)	0.906	(23.0)	0.984	(25.0)
18	2.559	(65.0)	0.453	(11.5)	0.575	(14.6)	0.862	(21.9)	0.941	(23.9)	2.756	(70.0)	0.709	(18.0)	0.575	(14.6)	0.965	(24.5)	1.102	(28.0)
20	2.677	(68.0)	0.500	(12.7)	0.736	(18.7)	1.031	(26.2)	1.165	(29.6)	2.756	(70.0)	0.709	(18.0)	0.728	(18.5)	1.122	(28.5)	1.260	(32.0)
22	2.677	(68.0)	0.500	(12.7)	0.819	(20.8)	1.031	(26.2)	1.165	(29.6)	2.756	(70.0)	0.709	(18.0)	0.819	(20.8)	1.201	(30.5)	1.339	(34.0)
24	2.756	(70.0)	0.500	(12.7)	0.969	(24.6)	1.358	(34.5)	1.488	(37.8)	2.756	(70.0)	0.709	(18.0)	0.969	(24.6)	1.358	(34.5)	1.496	(38.0)
28	2.795	(71.0)	0.500	(12.7)	1.063	(27.0)	1.358	(34.5)	1.488	(37.8)	2.756	(70.0)	0.709	(18.0)	1.063	(27.0)	1.476	(37.5)	1.614	(41.0)
32	2.913	(74.0)	0.598	(15.2)	1.311	(33.3)	1.717	(43.6)	1.882	(47.8)	2.953	(75.0)	0.709	(18.0)	1.311	(33.3)	1.732	(44.0)	1.890	(48.0)
36	2.913	(74.0)	0.598	(15.2)	1.516	(38.5)	1.717	(43.6)	1.882	(47.8)	3.346	(85.0)	0.709	(18.0)	1.516	(38.5)	2.008	(51.0)	2.165	(55.0)

**CB 4,6 STYLES**

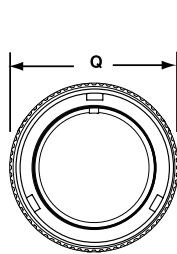

**CB6**

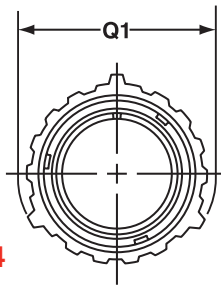

**CB4**

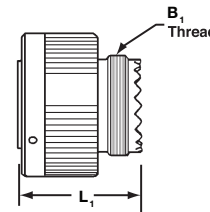

**CB6**

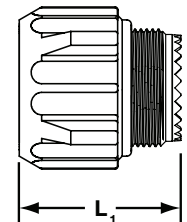

**CB4**

SHELL SIZE	Q MAX (CB6)		Q1 MAX (CB4)	
	IN	MM	IN	MM
10SL	0.898	(22.8)	1.122	(28.5)
12S	1.024	(26.0)	-	-
14S	1.150	(29.2)	1.378	(35.0)
16S	1.260	(32.0)	1.496	(38.0)
16	1.260	(32.0)	1.496	(38.0)
18	1.437	(36.5)	1.713	(43.5)
20	1.571	(39.9)	1.811	(46.0)
22	1.697	(43.1)	1.988	(50.5)
24	1.835	(46.6)	2.126	(54.0)
28	2.102	(53.4)	2.402	(61.0)
32	2.366	(60.1)	2.661	(67.6)
36	2.610	(66.3)	2.925	(74.3)

L <sub>1</sub> MAX		B <sub>1</sub> THREAD 2A
IN	MM	
0.969	(24.6)	9/16-24UNEF
0.969	(24.6)	5/8-24UNEF
0.969	(24.6)	3/4-20UNEF
0.969	(24.6)	7/8-20UNEF
1.343	(34.1)	7/8-20UNEF
1.343	(34.1)	1-20UNEF
1.343	(34.1)	1-1/8-18UNEF
1.343	(34.1)	1-1/4-18UNEF
1.406	(35.7)	1-3/8-18UNEF
1.406	(35.7)	1-5/8-18UNEF
1.469	(37.3)	1-7/8-16UN
1.469	(37.3)	2-1/8-16UN

CB 4,6 STYLES

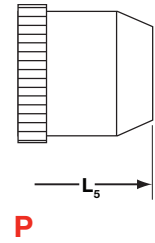
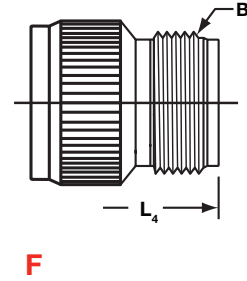
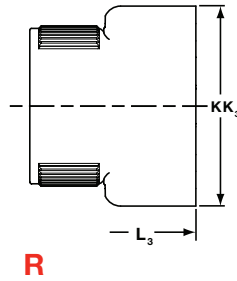
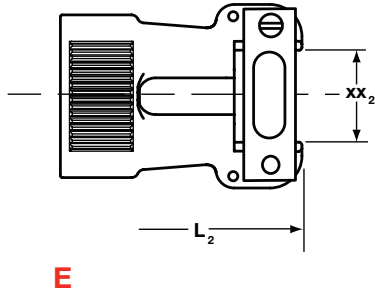

SHELL SIZE	L <sub>2</sub> MAX		XX <sub>2</sub> MAX		XX <sub>2</sub> MIN	
	IN	MM	IN	MM	IN	MM
10SL	2.165	(55.0)	0.256	(6.5)	0.140	(3.6)
12S	2.165	(55.0)	0.256	(6.5)	0.140	(3.6)
14S	2.362	(60.0)	0.354	(9.0)	0.195	(5.0)
16S	2.362	(60.0)	0.433	(11.0)	0.255	(6.5)
16	2.756	(70.0)	0.433	(11.0)	0.255	(6.5)
18	2.953	(75.0)	0.559	(14.2)	0.285	(7.2)
20	2.953	(75.0)	0.622	(15.8)	0.350	(8.9)
22	2.953	(75.0)	0.622	(15.8)	0.350	(8.9)
24	3.543	(90.0)	0.843	(21.4)	0.468	(11.9)
28	3.543	(90.0)	0.843	(21.4)	0.468	(11.9)
32	3.543	(90.0)	1.051	(26.7)	0.664	(16.9)
36	3.937	(100.0)	1.248	(31.7)	0.694	(17.6)

L <sub>3</sub> MAX		KK <sub>3</sub>	
IN	MM	IN	MM
1.969	(50.0)	0.378	(9.6)
1.969	(50.0)	0.406	(10.3)
1.969	(50.0)	0.488	(12.4)
1.969	(50.0)	0.606	(15.4)
2.362	(60.0)	0.606	(15.4)
2.441	(62.0)	0.724	(18.4)
2.441	(62.0)	0.866	(22.0)
2.441	(62.0)	0.972	(24.7)
2.441	(62.0)	1.087	(27.6)
2.441	(62.0)	1.244	(31.6)
2.441	(62.0)	1.516	(38.5)
2.441	(62.0)	1.752	(44.5)

L <sub>4</sub> MAX		B <sub>4</sub> THREAD 2A	L <sub>5</sub> MAX	
IN	MM		IN	MM
1.969	(50.0)	5/8-24UNEF	1.562	(39.7)
1.969	(50.0)	5/8-24UNEF	1.562	(39.7)
1.969	(50.0)	3/4-20UNEF	1.562	(39.7)
1.969	(50.0)	7/8-20UNEF	1.562	(39.7)
2.362	(60.0)	7/8-20UNEF	2.000	(50.8)
2.362	(60.0)	1-20UNEF	2.000	(50.8)
2.362	(60.0)	1-3/16-18UNEF	2.125	(54.0)
2.362	(60.0)	1-3/16-18UNEF	2.125	(54.0)
2.559	(65.0)	1-7/16-18UNEF	2.125	(54.0)
2.559	(65.0)	1-7/16-18UNEF	2.125	(54.0)
2.559	(65.0)	1-3/4-18NS	2.180	(55.4)
3.150	(80.0)	2-18NS	2.180	(55.4)

CB 6 ENDBELL STYLES

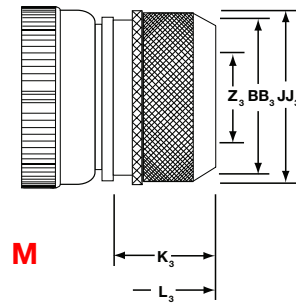
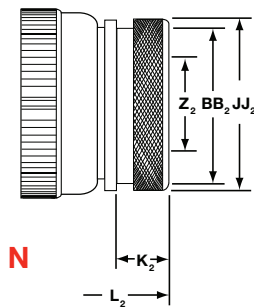

SHELL SIZE	L <sub>2</sub> MAX		K <sub>2</sub> MAX		Z <sub>2</sub> MIN		BB <sub>2</sub> MAX		JJ <sub>2</sub> ±.008(0.20)	
	IN	MM	IN	MM	IN	MM	IN	MM	IN	MM
10SL	1.969	(50.0)	0.461	(11.7)	0.303	(7.7)	0.524	(13.3)	0.610	(15.5)
12S	1.969	(50.0)	0.461	(11.7)	0.311	(7.9)	0.524	(13.3)	0.610	(15.5)
14S	1.969	(50.0)	0.461	(11.7)	0.417	(10.6)	0.669	(17.0)	0.752	(19.1)
16S	1.969	(50.0)	0.461	(11.7)	0.531	(13.5)	0.862	(21.9)	0.941	(23.9)
16	2.362	(60.0)	0.461	(11.7)	0.531	(13.5)	0.862	(21.9)	0.941	(23.9)
18	2.362	(60.0)	0.461	(11.7)	0.575	(14.6)	0.862	(21.9)	0.941	(23.9)
20	2.559	(65.0)	0.500	(12.7)	0.736	(18.7)	1.031	(26.2)	1.165	(29.6)
22	2.559	(65.0)	0.500	(12.7)	0.819	(20.8)	1.031	(26.2)	1.165	(29.6)
24	2.559	(65.0)	0.500	(12.7)	0.969	(24.6)	1.358	(34.5)	1.488	(37.8)
28	2.559	(65.0)	0.500	(12.7)	1.063	(27.0)	1.358	(34.5)	1.488	(37.8)
32	2.756	(70.0)	0.598	(15.2)	1.311	(33.3)	1.717	(43.6)	1.882	(47.8)
36	3.150	(80.0)	0.598	(15.2)	1.516	(38.5)	1.717	(43.6)	1.882	(47.8)

L <sub>3</sub> MAX		K <sub>3</sub> MAX		Z <sub>3</sub> MIN		BB <sub>3</sub> MAX		JJ <sub>3</sub> ±.008(0.20)	
IN	MM	IN	MM	IN	MM	IN	MM	IN	MM
2.165	(55.0)	0.669	(17.0)	0.303	(7.7)	0.642	(16.3)	0.728	(18.5)
2.165	(55.0)	0.669	(17.0)	0.366	(9.3)	0.669	(17.0)	0.787	(20.0)
2.165	(55.0)	0.669	(17.0)	0.417	(10.6)	0.787	(20.0)	0.866	(22.0)
2.362	(60.0)	0.709	(18.0)	0.531	(13.5)	0.906	(23.0)	0.984	(25.0)
2.756	(70.0)	0.709	(18.0)	0.531	(13.5)	0.906	(23.0)	0.984	(25.0)
2.756	(70.0)	0.709	(18.0)	0.575	(14.6)	0.965	(24.5)	1.102	(28.0)
2.756	(70.0)	0.709	(18.0)	0.728	(18.5)	1.122	(28.5)	1.260	(32.0)
2.756	(70.0)	0.709	(18.0)	0.819	(20.8)	1.201	(30.5)	1.339	(34.0)
2.756	(70.0)	0.709	(18.0)	0.969	(24.6)	1.358	(34.5)	1.496	(38.0)
2.756	(70.0)	0.709	(18.0)	1.063	(27.0)	1.476	(37.5)	1.614	(41.0)
2.756	(70.0)	0.709	(18.0)	1.311	(33.3)	1.732	(44.0)	1.890	(48.0)
3.150	(80.0)	0.709	(18.0)	1.516	(38.5)	2.008	(51.0)	2.165	(55.0)

**CB 6T ENDBELL STYLES**

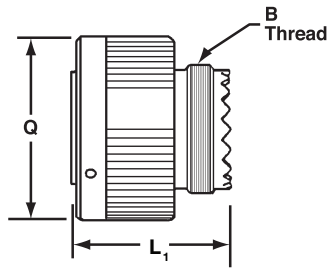

**CB6T BARREL**

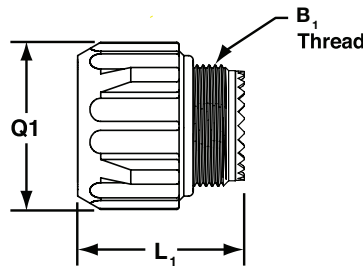

**CB4T BARREL**

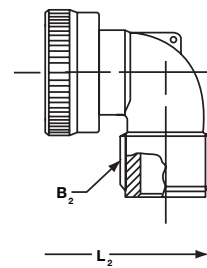

**CB6T ENDBELL**

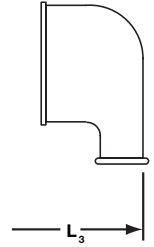

**CB6TP**

SHELL SIZE	Q (CB6) MAX		Q1 (CB4) MAX	
	IN	MM	IN	MM
10SL	0.898	(22.8)	1.122	(28.5)
12S	1.024	(26.0)	-	-
14S	1.150	(29.2)	1.378	(35.0)
16S	1.260	(32.0)	1.496	(38.0)
16	1.260	(32.0)	1.496	(38.0)
18	1.437	(36.5)	1.713	(43.5)
20	1.571	(39.9)	1.811	(46.0)
22	1.697	(43.1)	1.988	(50.5)
24	1.835	(46.6)	2.126	(54.0)
28	2.102	(53.4)	2.402	(61.0)
32	2.366	(60.1)	2.661	(67.6)
36	2.610	(66.3)	2.925	(74.3)

L <sub>1</sub>		B <sub>1</sub> THREAD 2A
IN	MM	
0.969	(24.6)	9/16-24UNEF
0.969	(24.6)	5/8-24UNEF
0.969	(24.6)	3/4-20UNEF
0.969	(24.6)	7/8-20UNEF
1.343	(34.1)	7/8-20UNEF
1.343	(34.1)	1-20UNEF
1.343	(34.1)	1-1/8-18UNEF
1.343	(34.1)	1-1/4-18UNEF
1.406	(35.7)	1-3/8-18UNEF
1.406	(35.7)	1-5/8-18UNEF
1.469	(37.3)	1-7/8-16UN
1.469	(37.3)	2-1/8-16UN

L <sub>2</sub> MAX		B <sub>2</sub> THREAD 2A
IN	MM	
2.188	(55.6)	5/8-24UNEF
2.188	(55.6)	5/8-24UNEF
2.312	(58.7)	3/4-20UNEF
2.406	(61.1)	7/8-20UNEF
2.781	(70.6)	7/8-20UNEF
2.844	(72.2)	1-20UNEF
3.250	(82.6)	1-3/16-18UNEF
3.250	(82.6)	1-3/16-18UNEF
3.719	(94.5)	1-7/16-18UNEF
3.719	(94.5)	1-7/16-18UNEF
4.188	(106.4)	1-3/4-18NS
4.297	(109.1)	2-18NS

L <sub>3</sub> MAX	
IN	MM
1.463	(37.2)
1.600	(40.6)
1.600	(40.6)
1.600	(40.6)
1.910	(48.5)
2.100	(53.3)
2.100	(53.3)
2.281	(57.9)
2.485	(63.1)
2.485	(63.1)
2.485	(63.1)

**CB7 STYLES**

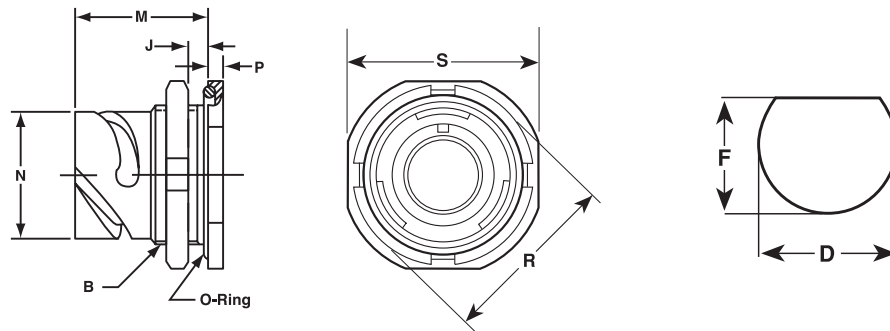

SHELL SIZE	B THREAD 2A	J MIN	J MAX	L	M	N	P	R	S	D	F
10SL	7/8-20UNEF	0.051 (1.3)	0.236 (6.0)	1.150 (29.2)	1.024 (26.0)	0.717 (18.2)	0.126 (3.2)	1.240 (31.5)	1.252 (31.8)	0.894 (22.7)	0.823 (20.9)
14S	1-1/8-18NEF	0.051 (1.3)	0.236 (6.0)	1.150 (29.2)	1.024 (26.0)	0.969 (24.6)	0.126 (3.2)	1.492 (37.9)	1.500 (38.1)	1.134 (28.8)	1.071 (27.2)
16S	1-1/4-18NEF	0.051 (1.3)	0.236 (6.0)	1.150 (29.2)	1.024 (26.0)	1.079 (27.4)	0.126 (3.2)	1.614 (41.0)	1.622 (41.2)	1.260 (32.0)	1.197 (30.4)
16	1-1/4-18NEF	0.051 (1.3)	0.236 (6.0)	1.484 (37.7)	1.358(34.5)	1.079 (27.4)	0.157 (4.0)	1.614 (41.0)	1.622 (41.2)	1.260 (32.0)	1.197 (30.4)
18	1-3/8-18NEF	0.051 (1.3)	0.236 (6.0)	1.575 (40.0)	1.417 (36.0)	1.213 (30.8)	0.157 (4.0)	1.764 (44.8)	1.772 (45.0)	1.382 (35.1)	1.323 (33.6)
20	1-1/2-18NEF	0.051 (1.3)	0.236 (6.0)	1.575 (40.0)	1.417 (36.0)	1.346 (34.2)	0.157 (4.0)	1.929 (49.0)	1.937 (49.2)	1.504 (38.2)	1.449 (36.8)
22	1-5/8-18NEF	0.051 (1.3)	0.236 (6.0)	1.575 (40.0)	1.417 (36.0)	1.472 (37.4)	0.157 (4.0)	2.055 (52.2)	2.063 (52.4)	1.654 (42.0)	1.571 (39.9)
24	1-3/4-18NEF	0.051 (1.3)	0.236 (6.0)	1.575 (40.0)	1.417 (36.0)	1.610 (40.9)	0.157 (4.0)	2.165 (55.0)	2.173 (55.2)	1.760 (44.7)	1.697 (43.1)
28	2-18NEF	0.051 (1.3)	0.236 (6.0)	1.575 (40.0)	1.417 (36.0)	1.839 (46.7)	0.157 (4.0)	2.441 (62.0)	2.449 (62.2)	2.012 (51.1)	1.937 (49.2)
32	2-1/4-16UN	0.051 (1.3)	0.236 (6.0)	1.575 (40.0)	1.417 (36.0)	2.102 (53.4)	0.157 (4.0)	2.677 (68.0)	2.685 (68.2)	2.260 (57.4)	2.193 (55.7)
36	2-1/2-16UN	0.051 (1.3)	0.236 (6.0)	1.575 (40.0)	1.417 (36.0)	2.346 (59.6)	0.157 (4.0)	2.953 (75.0)	2.961 (75.2)	2.512 (63.8)	2.441 (62.0)

All dimensions in inches (millimeters in parenthesis)

CB9 STYLES

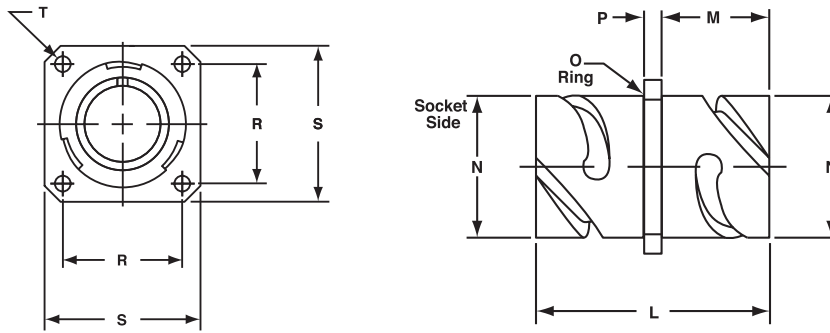

SHELL SIZE	M ±.012(0.30)		N ±.008(0.20)		P ±.008(0.20)		R ±.004(0.10)		S ±.012(0.30)		T		L ±.020(0.70)		PANEL THICKNESS	
	IN	MM	IN	MM	IN	MM	IN	MM	IN	MM	IN	MM	IN	MM	IN	MM
10SL	0.559	(14.2)	0.717	(18.2)	0.110	(2.8)	0.717	(18.2)	1.000	(25.4)	0.126	(3.2)	1.476	(37.5)	0.325	(8.2)
12S	0.559	(14.2)	0.843	(21.4)	0.126	(3.2)	0.811	(20.6)	1.102	(28.0)	0.126	(3.2)	1.476	(37.5)	0.325	(8.2)
14S	0.559	(14.2)	0.969	(24.6)	0.126	(3.2)	0.906	(23.0)	1.181	(30.0)	0.126	(3.2)	1.476	(37.5)	0.325	(8.2)
16S	0.559	(14.2)	1.079	(27.4)	0.126	(3.2)	0.969	(24.6)	1.280	(32.5)	0.126	(3.2)	1.476	(37.5)	0.325	(8.2)
16	0.748	(19.0)	1.079	(27.4)	0.126	(3.2)	0.969	(24.6)	1.280	(32.5)	0.126	(3.2)	2.024	(51.4)	0.445	(11.3)
18	0.748	(19.0)	1.213	(30.8)	0.157	(4.0)	1.063	(27.0)	1.378	(35.0)	0.126	(3.2)	2.024	(51.4)	0.445	(11.3)
20	0.748	(19.0)	1.346	(34.2)	0.157	(4.0)	1.157	(29.4)	1.496	(38.0)	0.126	(3.2)	2.024	(51.4)	0.445	(11.3)
22	0.748	(19.0)	1.472	(37.4)	0.157	(4.0)	1.252	(31.8)	1.614	(41.0)	0.126	(3.2)	2.024	(51.4)	0.445	(11.3)
24	0.811	(20.6)	1.610	(40.9)	0.157	(4.0)	1.374	(34.9)	1.752	(44.5)	0.146	(3.7)	2.024	(51.4)	0.383	(9.7)
28	0.811	(20.6)	1.839	(46.7)	0.157	(4.0)	1.563	(39.7)	2.000	(50.8)	0.146	(3.7)	2.024	(51.4)	0.383	(9.7)
32	0.874	(22.2)	2.102	(53.4)	0.157	(4.0)	1.752	(44.5)	2.244	(57.0)	0.169	(4.3)	2.024	(51.4)	0.320	(8.1)
36	0.874	(22.2)	2.346	(59.6)	0.157	(4.0)	1.937	(49.2)	2.500	(63.5)	0.169	(4.3)	2.024	(51.4)	0.383	(9.7)

CB PC PIN STLYES

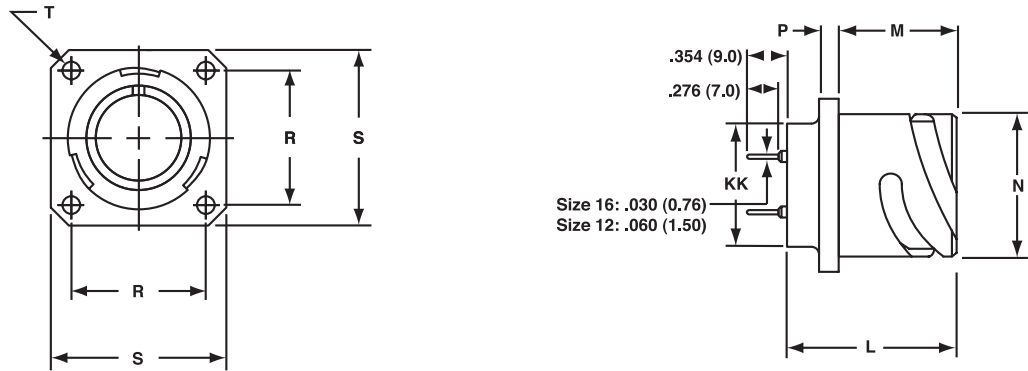

SHELL SIZE	M ±.016(0.40)		N ±.006(0.15)		P MAX		R ±.006(0.10)		S ±.016(0.40)		T		L ±.012(0.30)		KK MAX	
	IN	MM	IN	MM	IN	MM	IN	MM	IN	MM	IN	MM	IN	MM	IN	MM
10SL	0.717	(18.2)	0.717	(18.2)	0.110	(2.8)	0.717	(18.2)	1.000	(25.4)	0.126	(3.2)	0.972	(24.7)	0.638	(16.2)
12S	0.717	(18.2)	0.843	(21.4)	0.126	(3.2)	0.811	(20.6)	1.102	(28.0)	0.126	(3.2)	0.972	(24.7)	0.638	(16.2)
14S	0.717	(18.2)	0.969	(24.6)	0.126	(3.2)	0.906	(23.0)	1.181	(30.0)	0.126	(3.2)	0.972	(24.7)	0.756	(19.2)
16S	0.717	(18.2)	1.079	(27.4)	0.126	(3.2)	0.969	(24.6)	1.280	(32.5)	0.126	(3.2)	0.972	(24.7)	0.882	(22.4)
16	0.846	(21.5)	1.079	(27.4)	0.126	(3.2)	0.969	(24.6)	1.280	(32.5)	0.126	(3.2)	1.331	(33.8)	0.882	(22.4)
18	0.907	(23.1)	1.213	(30.8)	0.157	(4.0)	1.063	(27.0)	1.378	(35.0)	0.126	(3.2)	1.331	(33.8)	1.008	(25.6)
20	0.907	(23.1)	1.346	(34.2)	0.157	(4.0)	1.157	(29.4)	1.496	(38.0)	0.126	(3.2)	1.331	(33.8)	1.142	(29.0)
22	0.907	(23.1)	1.472	(37.4)	0.157	(4.0)	1.252	(31.8)	1.614	(41.0)	0.126	(3.2)	1.331	(33.8)	1.268	(32.2)
24	0.907	(23.1)	1.610	(40.9)	0.157	(4.0)	1.374	(34.9)	1.752	(44.5)	0.146	(3.7)	1.331	(33.8)	1.390	(35.3)
28	0.947	(24.1)	1.839	(46.7)	0.157	(4.0)	1.563	(39.7)	2.000	(50.8)	0.146	(3.7)	1.331	(33.8)	1.630	(41.4)
32	0.947	(24.1)	2.102	(53.4)	0.157	(4.0)	1.752	(44.5)	2.244	(57.0)	0.169	(4.3)	1.331	(33.8)	1.882	(47.8)
36	0.947	(24.1)	2.346	(59.6)	0.157	(4.0)	1.937	(49.2)	2.500	(63.5)	0.169	(4.3)	1.331	(33.8)	2.130	(54.1)

Note: Please contact us for centerline spacing of individual layouts.



**PANEL CUTOUTS**

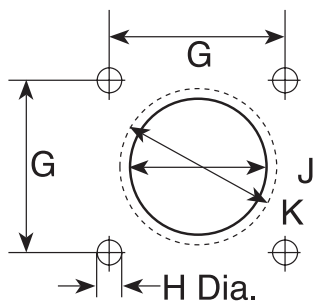

Dim. J=flange in front of panel  
 Dim. K=flange at rear of panel  
 → See sealing screws on page 195

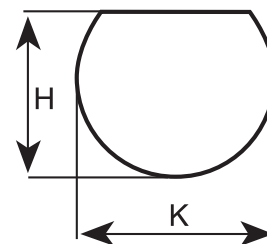

Note: for CB7 Panel cutouts  
 → See page 98

SHELL SIZE	FLANGE		STYLE 0-2-9 FRONT MOUNT	STYLE 0-2-9 REAR MOUNT
	MOUNTING	STYLE 0-2-9 HOLE DIAMETER		
	G	H	J	K
10SL	0.717 (18.2)	0.134 (3.4)	0.646 (16.4)	0.728 (18.5)
12S	0.811 (20.6)	0.134 (3.4)	0.646 (16.4)	0.854 (21.7)
14S	0.906 (23.0)	0.134 (3.4)	0.776 (19.7)	0.980 (24.9)
16S	0.969 (24.6)	0.134 (3.4)	0.902 (22.9)	1.091 (27.7)
16	0.969 (24.6)	0.134 (3.4)	0.902 (22.9)	1.091 (27.7)
18	1.063 (27.0)	0.134 (3.4)	1.028 (26.1)	1.224 (31.1)
20	1.157 (29.4)	0.134 (3.4)	1.161 (29.5)	1.358 (34.5)
22	1.252 (31.8)	0.134 (3.4)	1.287 (32.7)	1.488 (37.8)
24	1.374 (34.9)	0.154 (3.9)	1.417 (36.0)	1.626 (41.3)
28	1.563 (39.7)	0.154 (3.9)	1.654 (42.0)	1.854 (47.1)
32	1.752 (44.5)	0.177 (4.5)	1.902 (48.3)	2.118 (53.8)
36	1.937 (49.2)	0.177 (4.5)	2.150 (54.6)	2.362 (60.0)

STYLE CB7 REAR MOUNT	
H	K
0.823 (21)	0.894 (22.7)
0.949 (24)	1.012 (25.7)
1.071 (27)	1.134 (28.8)
1.197 (30)	1.260 (32.0)
1.197 (30)	1.260 (32.0)
1.323 (34)	1.382 (35.1)
1.449 (37)	1.504 (38.2)
1.571 (40)	1.654 (42.0)
1.697 (43)	1.760 (44.7)
1.937 (49)	2.012 (51.1)
2.193 (56)	2.260 (57.4)
2.441 (62)	2.512 (63.8)

**PANEL THICKNESS**

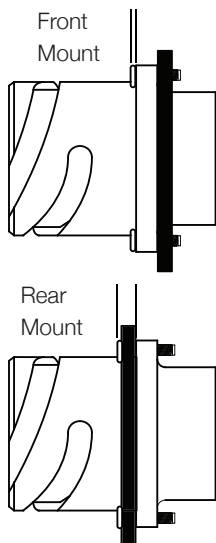

SHELL SIZE	REAR MOUNT	FRONT MOUNT
10SL	.315 (8.00)	.138 (3.50)
12S	.315 (8.00)	.138 (3.50)
14S	.315 (8.00)	.138 (3.50)
16S	.315 (8.00)	.138 (3.50)
16	.256 (6.50)	.138 (3.50)
18	.315 (8.00)	.138 (3.50)
20	.315 (8.00)	.138 (3.50)
22	.315 (8.00)	.138 (3.50)
24	.315 (8.00)	.197 (5.00)
28	.315 (8.00)	.197 (5.00)
32	.354 (9.00)	.236 (6.00)
36	.354 (9.00)	.236 (6.00)

All dimensions in inches (millimeters in parenthesis)

STYLE J

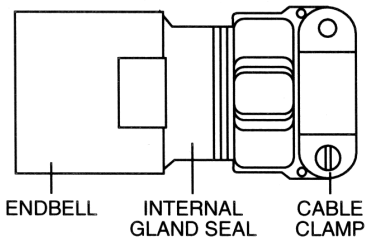

High-reliability, gland-seal endbell with an integrated compression disc that provides a watertight seal around the outside of a round, jacketed cable. Supplied with cable clamp. Wire sealing range is as follows:

SHELL SIZE	WIRE DIAMETER INCHES (MM)	
	MAX	MIN
10SL	.31 (8.0)	.13 (3.3)
14S	.44 (11.2)	.21 (5.3)
16S	.53 (13.5)	.32 (8.1)
16	.53 (13.5)	.32 (8.1)
18	.63 (15.9)	.43 (10.9)
20	.75 (19.1)	.49 (11.9)
22	.75 (19.1)	.49 (11.9)
24	.94 (23.9)	.67 (17.0)
28	.94 (23.9)	.67 (17.0)
32	1.25 (31.8)	.96 (24.4)
36	1.37 (34.9)	1.07 (27.4)

STYLE U (POTTED PREFERRED)

STYLE D (GROMMET & FERRULE, CONTACT US)

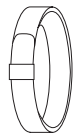
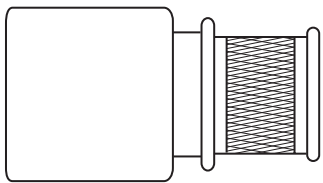

CONSTANT FORCE SPRING

ZT93-03-003-1 EMI SHIELD TAPE

BAND

This endbell is for use with unshielded, braided-shield or cable to terminate and extend the shield through the connector. There are three basic ways to terminate the U and D style endbell. One version uses a metal, constant-force spring to captivate the shield and can be reused/reworked if the connector needs to be serviced. The second version uses a stainless steel strap to lock the shield to the endbell. The third version is to use our conductive cloth EMI shield tape to easily tape the endbell to the shield. Heat shrink boots are used to environmentally seal the endbell and provide a smooth, finished appearance. → See pages 196-201 for boot

STYLE I

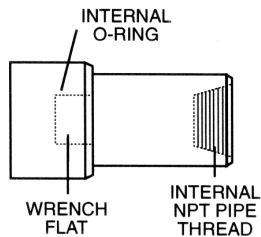

This endbell is internally threaded to accept externally threaded NPT pipe threads. A broad range of standard NPT thread sizes can be accommodated. Contact us for ordering information.

STYLE X

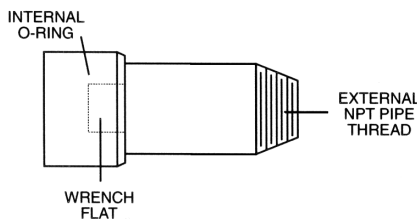

This endbell is externally threaded to accept internally threaded NPT pipe threads. A broad range of standard NPT thread sizes can be accommodated. Contact us for ordering information.

STYLE ST

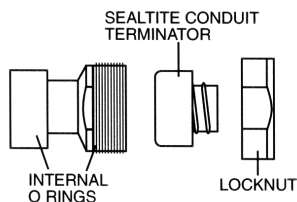

These endbells directly accept Sealtite conduit. A locknut and O-ring insures a watertight connection. Normally supplied straight but right angle and 45° versions are available. A broad range of Sealtite tubing diameters can be accommodated. Contact us for ordering information.

## STYLE E

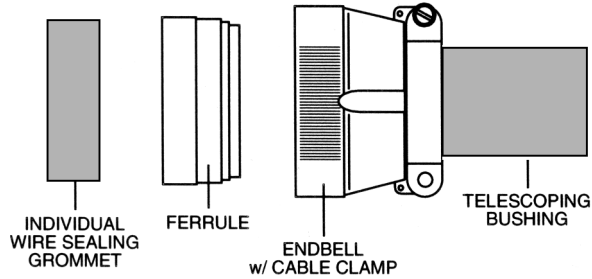

Supplied standard for CB only.

Endbell with integrated cable clamp that is supplied with individual wire-sealing grommet and ferrule. A telescoping neoprene bushing is captivated by the clamp. If desired, these bushings can be stacked to provide the optimum inside diameter for your cable.

⇒ See page 110 or contact us for ordering information

## STYLE R

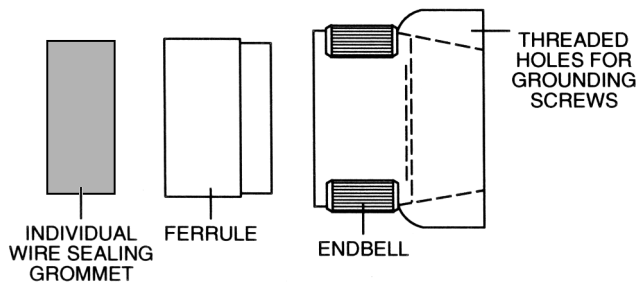

Endbell without cable clamp that is supplied with individual wire sealing grommet and ferrule. Rear section has two threaded holes to accommodate grounding screws or dust cap chains.

## STYLE N

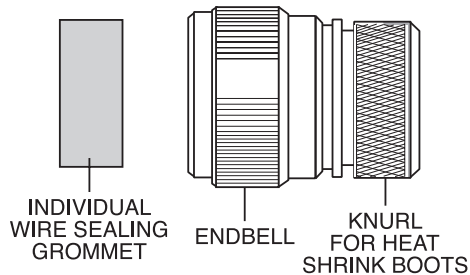

This endbell is designed for use with shrink boots or shrink tubing. A knurled rear section with ledge provides an excellent surface for the tubing to grab the metal endbell. Supplied with individual wire sealing grommet. Ferrule not required.

⇒ See Heat Shrink Boots on pages 196-201

## STYLE M

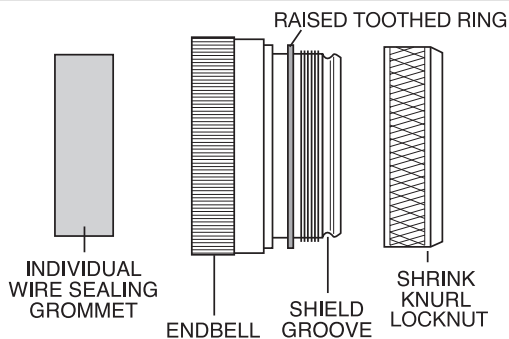

For use with braid-shielded cable to terminate and extend the shield through the connector. Typically used with a shrink boot. Supplied with individual wire sealing grommet; ferrule not required.

⇒ See Heat Shrink Boots on pages 196-201

## ASSEMBLY OF SHIELDED ENDBELL (USING OPTIONAL SHRINK BOOT)

1. Remove the locknut and slide shrink boot and locknut over cable in proper sequence for re-assembly.
2. Slide screen meshing on cable over the endbell so that it covers the rounded groove and locknut threads.
3. Fasten the screen into the rounded groove with baling wire.
4. Fold back the protruding screen over the baling wire.
5. Slide the locknut over the folded back screen so that the meshing is clamped under the nut and appears under the locknut facing the cable.
6. Tighten locknut.
7. Slide shrink boot over knurled locknut and raised toothed ring.
8. Shrink in place over the endbell first, then continue down the cable.

STYLE L

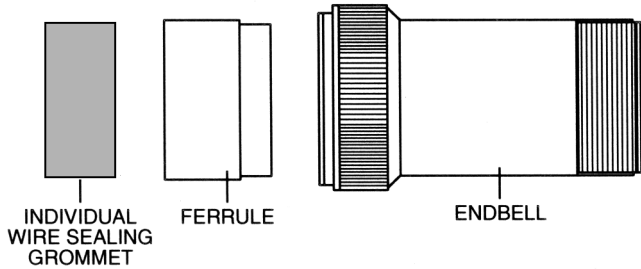

Long-extension endbell that allows additional room for wiring. Accepts Style A or C cable clamps.  
 ⇒ See pages 104-105 for cable clamps

STYLE F

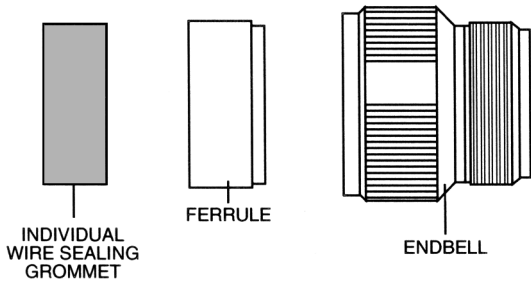

Standard endbell for use with Style A or C cable clamps. Supplied with individual wire sealing grommet and ferrule. This endbell can also be used with appropriately sized plastic flex tubing which is press-fit over the rear threads. ⇒ See pages 104-105 for cable clamps

STYLE T

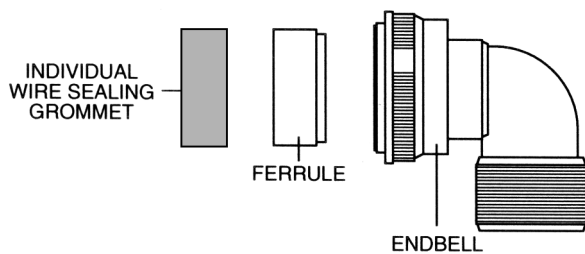

Right angle endbell supplied with individual wire sealing grommet and ferrule. Accepts Style A or C cable clamp. Internal teeth inside the endbell mate with teeth on the rear of the connector to allow the angled endbell to be locked into a specific orientation.  
 ⇒ See pages 104-105 for cable clamps

STYLE P

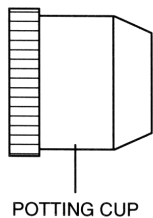

Potting cup endbell sealed with epoxy. After wire termination, the inside of the cup is filled with potting compound forming a solid, permanent, watertight seal around the wires.  
 ⇒ See pages 200 for potting compound and applicator

STYLE PG

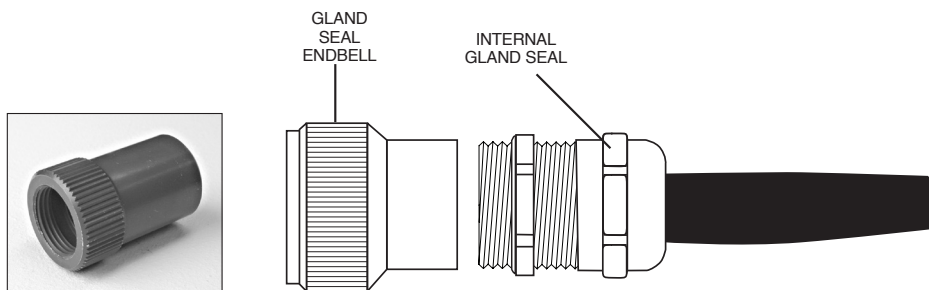

Lower-cost, metal, gland-seal endbell which comes in a variety of wire sealing ranges. Contact us with your cable outside diameter for appropriate part number.  
 ⇒ See pages 206-207

**MS3057-A CABLE CLAMP**

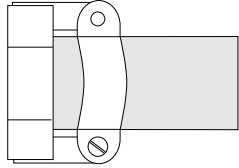

Standard MS3057 cable clamps have a dual clamping action to provide a balanced, positive hold on the wires and greatly reduce moisture transmission. This cable clamp accepts MS3420 bushings. MS3420 bushings can be nested to reduce the inside diameter to more closely match the diameter of the cable or wire bundle.

SHELL SIZE	THREAD 2B	STANDARD CLAMP				STANDARD CLAMP AND TELESCOPIC BUSHING		
		LOW COST CAST ZINC	ALUMINUM W/ BRASS SCREWS	ALUMINUM W/ STAINLESS STEEL SCREWS	MAXIMUM CABLE DIAMETER INCH (MM)	LOW COST ZINC WITH BUSHING	INCLUDES THIS BUSHING	BUSHING ID INCH (MM)
8S/ 10S	1/2-28UNEF	97-3057-1003*	MS3057-3A	M85049/41-3A	.220 (5.58)	97-3057-1003*-1	MS3420-3	0.130 (3.3)
10SL	5/8-24UNEF	97-3057-1004*	MS3057-4A	M85049/41-4A	.312 (7.92)	97-3057-1004*-1	MS3420-4	0.220 (5.6)
12/12S/12SL	5/8-24UNEF	97-3057-1004*	MS3057-4A	M85049/41-4A	.312 (7.92)	97-3057-1004*-1	MS3420-4	0.220 (5.6)
14/14S	3/4-20UNEF	97-3057-1007*	MS3057-6A	M85049/41-6A	.438 (11.13)	97-3057-1007*-1	MS3420-6	0.312 (7.9)
16/16S	7/8-20UNEF	97-3057-1008*	MS3057-8A	M85049/41-8A	.562 (14.27)	97-3057-1008*-1	MS3420-8	0.437 (11.1)
18	1-20UNEF	97-3057-1010*	MS3057-10A	M85049/41-10A	.625 (15.88)	97-3057-1010*-1	MS3420-10	0.562 (14.3)
20/22	1 3/16-18UNEF	97-3057-1012*	MS3057-12A	M85049/41-12A	.750 (19.05)	97-3057-1012*-1	MS3420-12	0.625 (15.9)
24/28	1 7/16-18UNEF	97-3057-1016*	MS3057-16A	M85049/41-16A	.938 (23.83)	97-3057-1016*-1	MS3420-16, -12	0.625 (15.9)
32	1 3/4-18UNS	97-3057-1020*	MS3057-20A	M85049/41-20A	1.250 (31.75)	97-3057-1020*-1	MS3420-20, -16	0.750 (19.1)
36	2-18UNS	97-3057-1024*	MS3057-24A	M85049/41-24A	1.375 (34.92)	97-3057-1024*-1	MS3420-24, -20	0.937 (23.8)
40	2 1/4UNS-16	-	MS3057-28A	M85049/41-28A	1.625 (41.28)	-	-	-

\*Default plating - Olive drab chromate over cadmium  
-621 = Black Alloy (RoHS)

**MS3057-C WATERPROOF CABLE CLAMP**

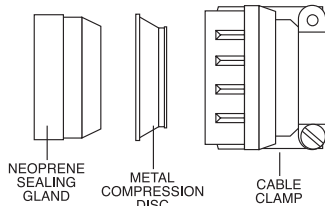

Standard MS3057-C waterproof cable clamp with mechanical strain relief for use with style F, L and T endbells. Internal neoprene gland and compression ring will seal a broad range of round cable diameters as listed below. For reduction of cable diameters, order the appropriate MS3420A bushing in table.

SHELL SIZE	PART NUMBER	WIRE DIAMETER INCHES (MM)		OPTIONAL BUSHINGS	
		MAX.	MIN.	PART NUMBER	MAX. WIRE DIA. (MM)
10SL/12S	MS3057-4C	.312 (7.93)	.188 (4.80)	MS3420-4A	.219 (5.56)
14S	MS3057-6C	.438 (11.12)	.281 (7.10)	MS3420-6A MS3420-4A	.312 (7.93) .219 (5.56)
16/16S	MS3057-8C	.530 (13.48)	.312 (7.90)	MS3420-8A MS3420-6A	.438 (11.10) .312 (7.93)
18	MS3057-10C	.625 (15.87)	.375 (9.50)	MS3420-10A MS3420-6A	.438 (11.10) .312 (7.93)
20/22	MS3057-12C	.750 (19.00)	.500 (12.70)	MS3420-12A MS3420-8A	.540 (13.74) .438 (11.10)
24/28	MS3057-16C	.940 (23.8)	.625 (15.90)	MS3420-16A MS3420-12A MS3420-8A	.750 (19.00) .540 (13.74) .438 (11.10)
32	MS3057-20C	1.25 (31.75)	.921 (23.4)	MS3420-20A MS3420-16A MS3420-12A	.938 (23.80) .750 (19.00) .540 (13.74)
36	MS3057-24C	1.38 (35.00)	1.00 (25.40)	MS3420-24A MS3420-18A MS3420-16A	1.12 (28.5) .938 (23.80) .750 (19.00)
40	MS3057-28C	1.62 (41.25)	1.25 (31.80)	MS3420-28A MS3420-20A MS3420-16A	1.25 (31.75) .940 (23.80) .750 (19.00)

All dimensions in inches (millimeters in parenthesis)

**MS3420 TELESCOPING BUSHINGS**

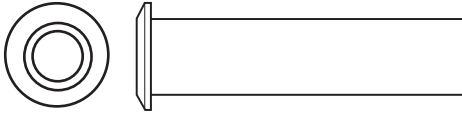

For use with style A cable clamps and CB/CT style E/F endbells to eliminate dust, dirt and oil from entering the cable clamp. Bushings can be nested, one inside the other, to reduce the inside diameter and form a better seal against the cable jacket. Each bushing will accept the next smallest bushing.

SHELL SIZE	1ST BUSHING PART NUMBER	INSIDE DIAMETER	2ND NESTED BUSHING	INSIDE DIAMETER	FITS IN CABLE CLAMP
10SL	MS3420-4	.220 (5.59)	NONE	-	MS3057-4A
12S	MS3420-4	.220 (5.59)	NONE	-	MS3057-4A
14S	MS3420-6	.312 (7.92)	NONE	-	MS3057-6A
16S	MS3420-8	.437 (11.10)	NONE	-	MS3057-8A
16	MS3420-8	.437 (11.10)	NONE	-	MS3057-8A
18	MS3420-10	.562 (14.30)	NONE	-	MS3057-10A
20	MS3420-12	.625 (15.90)	NONE	-	MS3057-12A
22	MS3420-12	.625 (15.90)	NONE	-	MS3057-12A
24	MS3420-16	.750 (19.05)	MS3420-12	.625 (15.90)	MS3057-16A
28	MS3420-16	.750 (19.05)	MS3420-12	.625 (15.90)	MS3057-16A
32	MS3420-20	.937 (23.80)	MS3420-16	.750 (19.05)	MS3057-20A
36	MS3420-24	1.250 (31.75)	MS3420-20	.937 (23.80)	MS3057-24A
40	MS3420-28	1.375 (34.92)	MS3420-24	1.250 (31.75)	SE96-28A4

All dimensions in inches (millimeters in parenthesis)

**MS3420-A REDUCTION BUSHINGS**



For use with MS3057-C cable clamps (Style C) to reduce the wire sealing diameter. Bushings can be nested, one inside the other, to progressively reduce the inside diameter of the cable clamp. The column labeled Optional Bushings shows the acceptable nesting options for each clamp.

**9767 CABLE CLAMPS**



9767 waterproof cable clamp with mechanical strain relief. An internal neoprene gland seal bushing and compression washer will seal a broad range of round cable diameters as listed below.

SHELL SIZE	CABLE CLAMP PART NUMBER	MAX. CABLE OD		MIN. CABLE OD		THREAD 2B
		INCHES	(MM)	INCHES	(MM)	
10SL, 12S	9767-12-4*	0.219	(5.55)	0.020	(0.51)	5/8-24 UNEF
14S	9767-14-4*	0.219	(5.55)	0.020	(0.51)	3/4-20 UNEF
14S	9767-14-6*	0.344	(8.73)	0.176	(4.47)	3/4-20 UNEF
16S, 16	9767-16-4*	0.219	(5.55)	0.020	(0.51)	7/8-20 UNEF
16S, 16	9767-16-6*	0.344	(8.73)	0.176	(4.47)	7/8-20 UNEF
16S, 16	9767-16-8*	0.438	(11.12)	0.177	(4.50)	7/8-20 UNEF
18	9767-18-6*	0.344	(8.73)	0.176	(4.47)	1-20 UNEF
18	9767-18-8*	0.438	(11.12)	0.177	(4.50)	1-20 UNEF
18	9767-18-10*	0.563	(14.29)	0.292	(7.42)	1-20 UNEF
20, 22	9767-22-8*	0.438	(11.12)	0.177	(4.50)	1-3/16-18 UNEF
20, 22	9767-22-10*	0.563	(14.29)	0.292	(7.42)	1-3/16-18 UNEF
20, 22	9767-22-12*	0.688	(17.46)	0.370	(9.40)	1-3/16-18 UNEF
24, 28	9767-28-10*	0.563	(14.29)	0.292	(7.42)	1-7/16-18 UNEF
24, 28	9767-28-12*	0.688	(17.46)	0.370	(9.40)	1-7/16-18 UNEF
24, 28	9767-28-16*	0.844	(21.43)	0.536	(13.61)	1-7/16-18 UNEF
32	9767-32-20*	1.031	(26.19)	0.590	(14.99)	1-3/4-18 UNS
36	9767-36-16*	0.844	(21.43)	0.536	(13.61)	2-18 UNS

\*Default plating - Olive drab chromate over cadmium  
-621 = Black Alloy (RoHS)

GASKETS

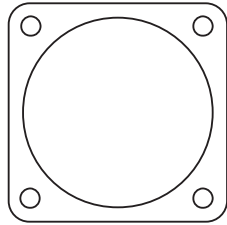

POLYCHLOROPRENE gaskets are used to ensure a moisture tight seal between a receptacle and the panel. Gaskets are available for front or rear panel mounting of STYLE 0, 2, and 9 connectors. Gasket thickness is approximately .037" (1.0 mm).

ALU-FLEX gaskets contain an imbedded metal screen for EMI/RFI shielding in addition to moisture sealing. Gaskets are available for front or rear panel mounting of STYLE 0, 2, and 9 connectors. Gasket thickness is .019" (.5 mm).

SHELL SIZE	FRONT MOUNTING		REAR MOUNTING	
	NON-CONDUCTIVE	CONDUCTIVE	NON-CONDUCTIVE	CONDUCTIVE
10S, 10SL	MS52000-2	075-8512-001	075-8501-000	075-8501-001
12S, 12	MS52000-3	075-8513-001	075-8502-000	075-8502-001
14S, 14	MS52000-4	075-8514-001	075-8503-000	075-8503-001
16S	MS52000-5	075-8515-001	075-8504-000	075-8504-001
16	MS52000-5	075-8515-001	075-8504-000	075-8504-001
18	MS52000-6	075-8516-001	075-8505-000	075-8505-001
20	MS52000-7	075-8517-001	075-8506-000	075-8506-001
22	MS52000-8	075-8518-001	075-8507-000	075-8507-001
24	MS52000-9	075-8519-001	075-8508-000	075-8508-001
28	MS52000-10	075-8520-001	075-8509-000	075-8509-001
32	MS52000-12	075-8521-001	075-8510-000	075-8510-001
36	MS52000-13	075-8522-001	075-8511-000	075-8511-001

METAL DUST CAPS WITH SASH CHAIN

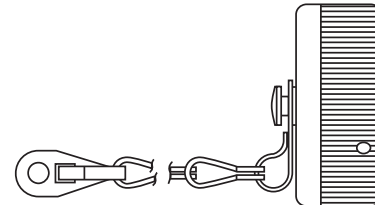
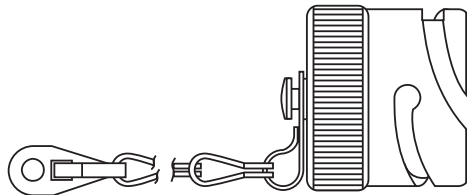

SHELL SIZE	FOR PLUG STYLES 4 & 6			FOR RECEPTACLE STYLES 0, 1, 2, 7, & 9		
	CAD OD	A232	A34	CAD OD	A232	A34
10SL	CA121004-1	CA121004-71	CA121004-701	CA121003-1	CA121003-71	CA121003-701
12S	CA121004-2	CA121004-72	CA121004-702	CA121003-2	CA121003-72	CA121003-702
14S	CA121004-3	CA121004-73	CA121004-703	CA121003-3	CA121003-73	CA121003-703
16S	CA121004-4	CA121004-74	CA121004-704	CA121003-4	CA121003-74	CA121003-704
16	CA121004-5	CA121004-75	CA121004-705	CA121003-5	CA121003-75	CA121003-705
18	CA121004-6	CA121004-76	CA121004-706	CA121003-6	CA121003-76	CA121003-706
20	CA121004-7	CA121004-77	CA121004-707	CA121003-7	CA121003-77	CA121003-707
22	CA121004-8	CA121004-78	CA121004-708	CA121003-8	CA121003-78	CA121003-708
24	CA121004-9	CA121004-79	CA121004-709	CA121003-9	CA121003-79	CA121003-709
28	CA121004-10	CA121004-80	CA121004-710	CA121003-10	CA121003-80	CA121003-710
32	CA121004-11	CA121004-81	CA121004-711	CA121003-11	CA121003-81	CA121003-711
36	CA121004-12	CA121004-82	CA121004-712	CA121003-12	CA121003-82	CA121003-712

A233, A239, A240 platings available, please contact us.

## DUMMY RECEPTACLES

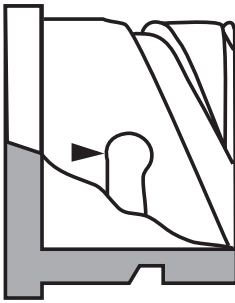

Dummy Receptacles are for front or rear panel mounting. CB/CAB series have bayonet ramps; the center of the connector is closed. Dummy receptacles mount on the same centers and have the same outside dimensions as a STYLE 2 receptacle. The material is aluminum alloy and has an olive chromate over cadmium plating. A version with a clearance hole through the middle of the connector is also available. Contact us for ordering information.

SHELL SIZE	CB/CAB
10SL	248-8501-000
12S	248-8502-000
14S	248-8503-000
16S	248-8504-000
16	248-8505-000
18	248-8506-000
20	248-8507-000
22	248-8508-000
24	248-8509-000
28	248-8510-000
32	248-8511-000
36	248-8512-000

⇒ See Accessories section for sealing screws on page 195

## SEAL RINGS

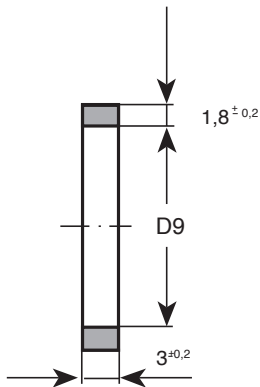

Replacement seal rings for CB series STYLE 4 and 6 connectors.

SHELL SIZE	NEOPRENE	SILICONE	D9 INSIDE DIA. INCHES (MM)
10SL	980-8550-000	980-8550-002	.354 (9.0)
12S	980-8551-000	N/A	.452 (11.5)
14S	980-8552-000	980-8552-002	.551 (14.0)
16/16S	980-8553-000	980-8553-002	.670 (17.0)
18	980-8554-000	980-8554-002	.768 (19.5)
20	980-8555-000	980-8555-002	.886 (22.5)
22	980-8556-000	980-8556-002	1.00 (25.4)
24	980-8557-000	980-8557-002	1.12 (28.5)
28	980-8558-000	980-8558-002	1.38 (34.0)
32	980-8559-000	980-8559-002	1.57 (40.0)
36	980-8560-000	980-8560-002	1.83 (45.0)
40	N/A	980-8561-002	1.97 (50.0)

All dimensions in inches (millimeters in parenthesis)



## 1. SOLDER CONTACTS

**STEP 1:** Slide the rear accessories over the wire bundle in the proper sequence for reassembly: cable clamp and/or endbell first, then ferrule and (if used) coupling nut.

**STEP 2:** Insert individual wires through the proper holes in the grommet. Use isopropyl alcohol as a lubricant.

**STEP 3:** Solder wires to appropriate contacts on the rear of the connector. ITT Cannon document RPI234 covers standard soldering practices and is available upon request by fax or mail, please contact us.

**STEP 4:** Fixture the connector for reassembly using endbell assembly tools.

**STEP 5:** Slide the grommet down the wires (lubricating the grommet with isopropyl alcohol will help).

**STEP 6:** Fill all unused grommet cavities with a wire hole filler to maintain the sealing integrity of the connector.

**STEP 7:** Slide coupling nut, ferrule and endbell accessories over rear of the connector and tighten.

## 2. CRIMP TOOL OPERATION

**NOTE:** Hand crimp tools can be used with size 16S, 16 & 12 contacts. Size 8, 4 and 0 contacts require the use of air powered crimp tools. Contact us for assistance in the use of these tools.

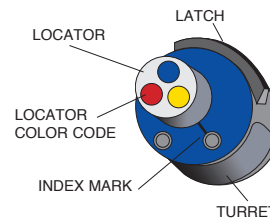
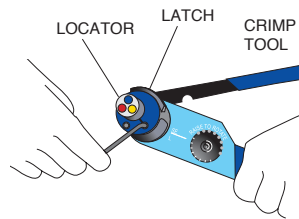

**STEP 1:** Strip the wires to the appropriate length.

**STEP 2:** Open the AF8 crimp tool by squeezing the handles. Push the latch on the turret to pop up the locator. Attach the turret to the crimp tool using the two captive hex bolts in the turret.

**STEP 3:** Select the proper locator position for your contact by rotating the locator until the proper color is aligned with the index mark. Push locator back down until it snaps into position.

TH452		
CONTACT SIZE	PIN LOCATOR COLOR	SOCKET LOCATOR COLOR
16S	BLUE	GREEN
16	GREEN	RED
12	RED	RED

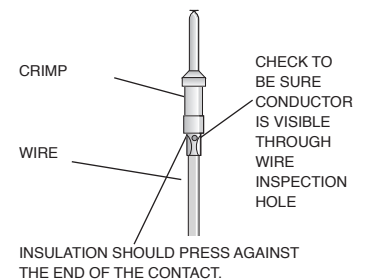
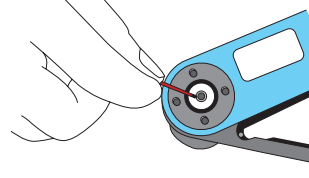
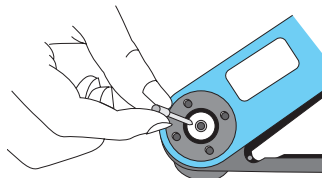
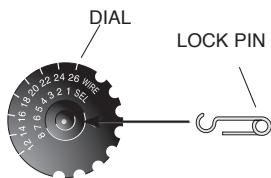

**STEP 4:** Adjust dial for proper wire gauge. To change the dial setting, remove the lock pin and lift center of dial. Turn to the desired wire gauge. Replace lock pin on dial.

**STEP 5:** Cycle the tool before inserting the contact to be sure the tool is in the open position. Drop the contact, mating end first, into the crimp cavity of the tool. Squeeze the tool handle just enough to grip the contact without actually crimping it.

**STEP 6:** Insert the stripped wire into the contact with a slight twisting motion. Be sure all wire strands are inside the contact. Squeeze the handle to cycle the tool. The handle will not release until the contact is completely crimped.

**STEP 7:** Remove the crimped contact. Pull on the wire slightly to be sure it is properly crimped. Be sure the contact is not bent or damaged in any way. Visually inspect the crimp.

**MICRO SECTIONS:** Enlargement of microsection allows for final judgement of crimp quality. This test is recommended whenever new tools or new types of wire or contacts are used.

3. INSERTION OF CONTACTS

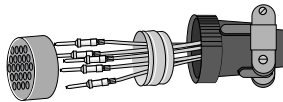

**STEP 1:** Slide the rear accessories over the wire bundle in the proper sequence for reassembly: cable clamp and/or endbell first, then ferrule, and (if used) coupling nut.

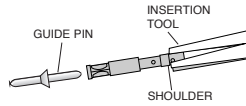

**STEP 2:** Use the proper insertion tool. Place the contact in the tool. The tool should press against the shoulder of the contact. Contact sizes 16S, 16, and 12 use a pliers style tool. Contact sizes 8, 4 and 0 use a tool with a 'C' shaped shaft.

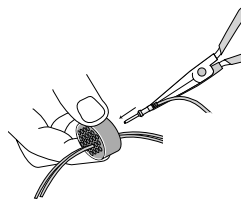

**STEP 3:** Lubricate the grommet with isopropyl alcohol (do not use any lubricant other than isopropyl alcohol). Insert the contact through the appropriate cavity in the grommet. Sizes 16S, 16 and 12 SOCKET contacts must be installed using guide pins.

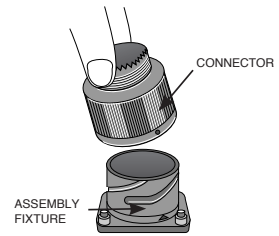

**STEP 4:** Place the connector into an assembly fixture (fixtures are available for production use, contact us). If you are not using a fixture, be sure to allow clearance on the mating face of the connector for the guide pins to come through the connector during insertion.



**STEP 5:** Lubricate the contact cavities of the connector insulator with isopropyl alcohol (do not use any other type of lubricant).

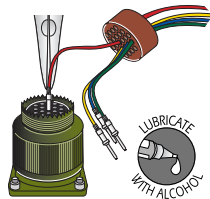

**STEP 6:** Using guide pins where necessary, push straight down with a firm even pressure until the contact snaps into position in the proper cavity. Start at the center of the pattern and work toward the outer edges.

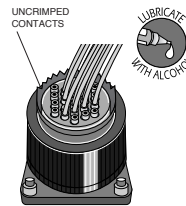

**STEP 7:** Fill any unused cavities with contacts.



**STEP 8:** Check the mating face of the connector to insure that all the same size contacts are on the same plane (fully inserted). If not, the contact is not fully inserted. Remove the contact using the proper extraction tool and procedure and re-insert. Do not attempt to reinsert the insertion tool to correct the problem.

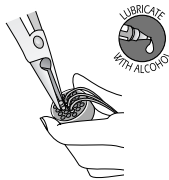

**STEP 9:** A wire hole filler must be inserted into the grommet behind the unused contacts to maintain the sealing integrity of the connector.

**STEP 10:** Place the connector back in the fixture for reassembly. Slide the connector accessories back down the cable over the rear of the connector and tighten.

4. EXTRACTION OF CONTACTS

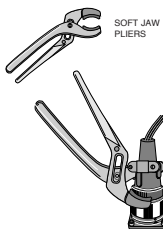

**STEP 1:** Remove the endbell accessories and slide them back over the wires.

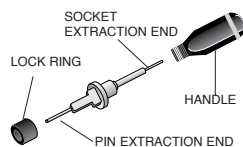

**STEP 2:** Use the proper extraction tool. The extraction tool can be used for both pin and socket contacts by removing the shaft from the handle and reversing it for pin or socket extraction.

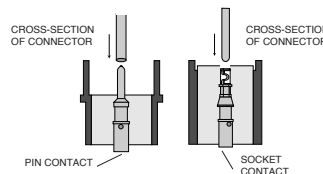

**STEP 3:** On the mating face of the connector, insert the tool over the pin contact or into the socket contact until the tool bottoms. Apply a slow continuous pressure to push the contact out the rear of the connector. When the shoulder of the tool "thunks" against the insulator, the contact is extracted.

**STEP 4:** Carefully remove the extraction tool from the connector to avoid damage to the insulator.

## CA-BAYONET CONNECTORS

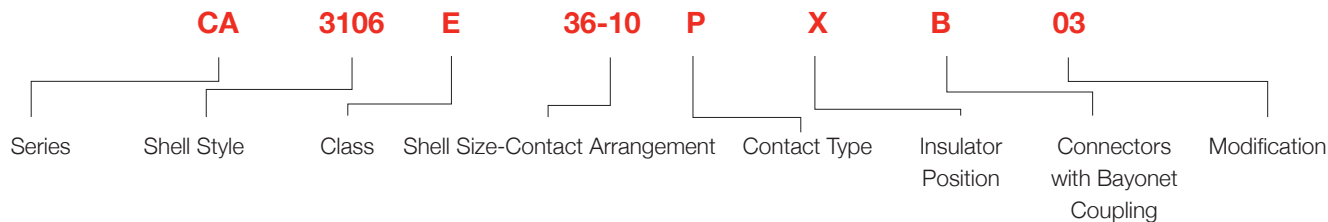

## EXPLANATION

## SERIES

CA - Circular connectors with bayonet coupling

## SHELL STYLE

3100 - Wall mounting receptacle (metric thread holes standard w/o mod)

3101 - Cable connecting plug (receptacle)

3102 - Box mounting receptacle

3106 - Plug, straight

3108 - Plug, 90°

TBF - Bulkhead receptacle

## CLASS

E - Environmental with resilient insulators and endbell with clamp and bushing

F - Environmental with resilient insulator and endbell for flex tube

R - Environmental with resilient insulator and shortened light-weight endbell without cable clamp

## SHELL SIZE

10SL, 12S, 14S, 16S, 16, 18, 20, 22, 24, 28, 32, and 36

## CONTACT ARRANGEMENT

⇒ See pages 76-89

## CONTACT TYPE

P - Pin

S - Socket

PS - One side pin, one side socket (only for TBF)

## INSULATOR POSITION

Besides the normal position further insulator positions are possible for Cannon connectors to prevent mismatching. Polarization is achieved by turning the pin contact insulator clockwise; the socket insulator, counter clockwise. This information refers to the mating side of the contact insulator.

## MODIFICATION

01 - Metric crimp contacts

02 - Adapter for heat shrink boots, AWG crimp\*

03 - Adapter for heat shrink boots, metric contacts\*

04 - Rear mount, thread in flange, metric crimp contacts (for CA3102 only)

05 - Rear mount through holes in flange (for CA3102 and CA3100 only)

06 - Shrink boot adapter, solder contacts\*

08 - Angular endbell, threaded holes in flange (for CA3100 only)

09 - Angular endbell, through holes in flange (for CA3100 only)

13 - Shielded version, solder contacts\*

14 - Shielded version, metric crimp contacts\*

15 - Shielded version, AWG crimp contacts\*

109 - F80, rear mount, thread holes in flange (for CA3102 and CA3100 only)

111 - Rear mount, thread holes, solder contacts (for CA3102 only)

F80 - AWG crimp contacts

A34 - Bright nickel

A152 - Heavy gold plated contacts

A176 - Gold plated contacts

A232 - Black zinc cobalt

A233 - Green zinc cobalt

39 - Rubber cover coupling nut

A239 - Conductive Black RoHS 500 Hr Salt Spray

A240 - Conductive Blue RoHS 500 Hr Salt Spray

## WITH SPRING WASHER AND FRICTION RING

These connectors feature a spring washer and a friction ring under the coupling nut. Used in high vibration applications.

CA06EW - Connector with spring washer, endbell with cable and bushing

CA06FW - Connector with spring washer, endbell and protect hose

CA06RW - Connector with spring washer and short endbell

\* Boot ordered separately. ⇒ See pages 196-201.

## OTHER SHELL STYLES

CA3100E-B-02/03/06 - Adapter for heat shrink boot

CA3100F-B-08/09 - 90° endbell for flex tube

CA3100E-B-08/09 - 90° endbell, cable clamp and busing

CA06PG-B - PG adapter

CA3101E-B-02/03/06 - Adapter for heat shrink boots

CA3101F-B-08/09 - 90° endbell flex tube

CA02L-B - Receptacle with PC contacts

CA20L-B - Rear mount receptacle with PC contacts

CA07A-B - Jam nut receptacle

## HAVE A UNIQUE REQUIREMENT?

Quick assembly of custom products is our specialty! Email us at [sales@peigenesis.com](mailto:sales@peigenesis.com) or complete our online Technical Request at [www.peigenesis.com/technical-support](http://www.peigenesis.com/technical-support). To contact us by phone, please see the back cover for a complete listing of our branch offices and contact numbers.