

REV.	DESCRIPTION	DATE	APPROVED
A	Engineering Release	05/12/17	J. C.

*Length "X.X"	Tolerance
2.0" ~ 16.0"	±0.05"
16.1" ~ 40.0"	±0.15"
40.1" ~ 80.0"	±0.30"
80.1" ~ 500.0"	±0.5%

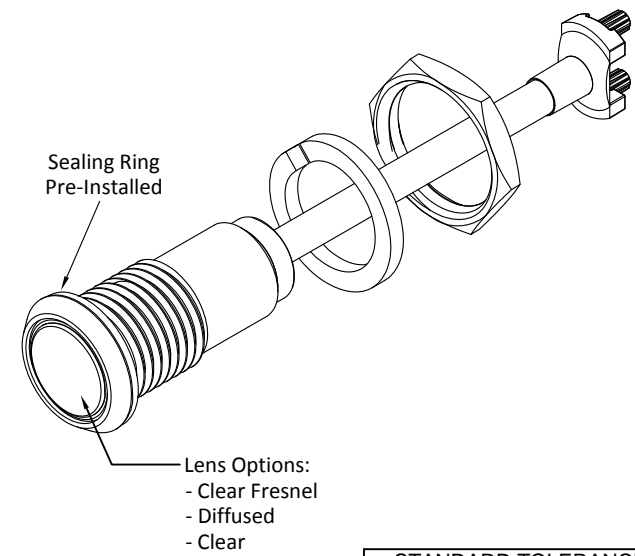
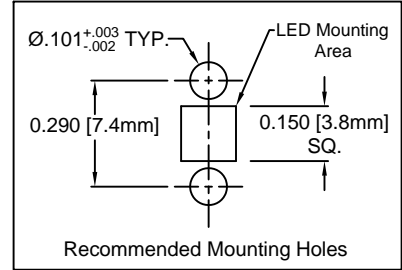
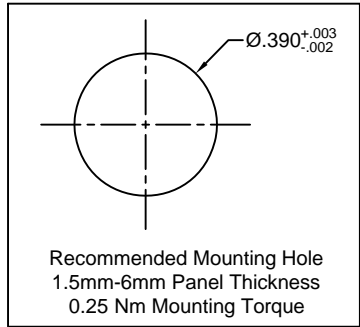
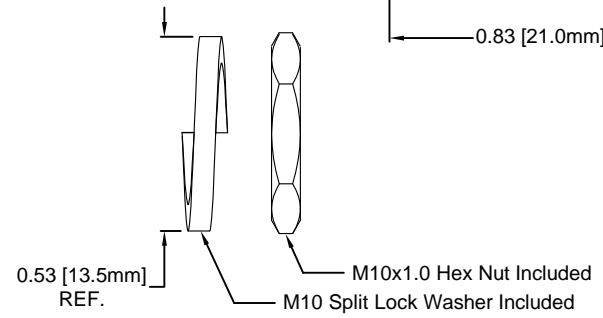
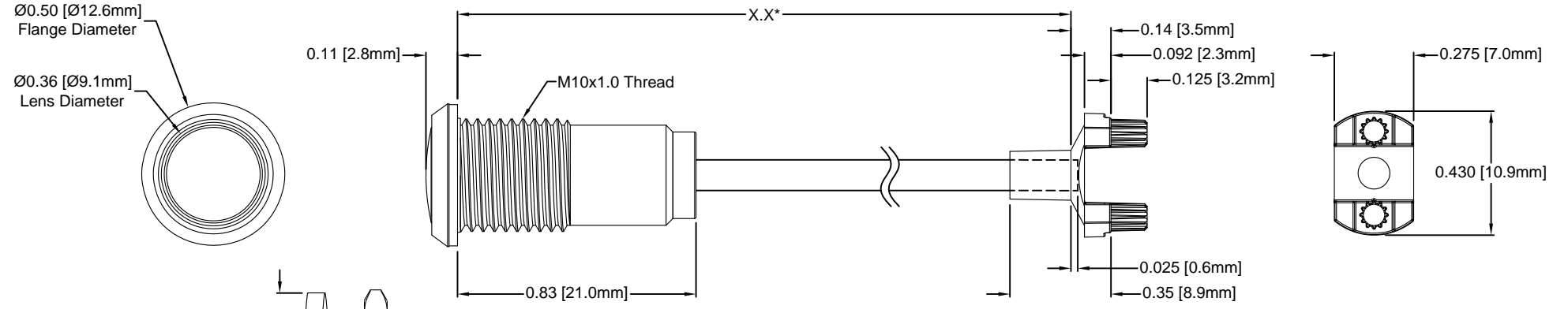

Part Number Configuration
SF3-6.5-F9PX67PR

Lens Options:
 Z – Clear Fresnel
 D – Diffused
 Blank – Clear

Length in 0.1"
 Increments Only

- NOTES:**
1. SEALED TO IP67 RATING
 2. ROHS COMPLIANT
 3. MOUNTING HARDWARE AND ADAPTER SHIPPED NON-ASSEMBLED
 4. MINIMUM BEND RADIUS OF FLEXIBLE LIGHT PIPE: 1.06" [27mm]

STANDARD TOLERANCE (UNLESS OTHERWISE SPECIFIED)		BIVAR®	
DECIMALS	ANGULAR	4 THOMAS, IRVINE, CA. 92618	
.X ± .1	X° ± 1°	TEL: (949) 951-8808 FAX: (949) 951-3974	
.XX ± .02		TITLE: IP67 RATED PANEL MOUNT FLP INDICATOR, SMFLP	
.XXX ± .010		PART NO: SF3-X.X-F9PX67PR	
DESIGNED: TD. Nguyen	DATE: 04/30/17	REVISION: A	
CHECKED: K. Baron	DATE: 04/30/17	CAGE CODE : 32559	SHEET # 1 OF 1
CAD GENERATED DOCUMENT. DO NOT MEASURE DRAWING.			