

SERIES 76-95 – VANDAL RESISTANT RANGE

FEATURES

- Vandal resistant
- Panel sealed to IP67
- Form Z contacts to cover all switching requirements
- Attractively machined from stainless steel
- Wide temperature range of -30°C to +105°C
- Microswitch action
- Rear mounting version can be mounted to appear totally flush
- Solder terminals
- High contact rating – 10A, 250V a.c. (resistive load at 70°C)

NON-STANDARD OPTIONS

- Solder/faston terminals
- PCB terminals
- Gold contacts
- Two pole version
- Special operating forces

Technical Information

Series 76-95

Having been designed to withstand impacts of significant force, the 76-95 Series of pushbutton switches are extremely rugged making them particularly suited to applications in which vandal resistance is a necessity.

The switch body and buttons are machined from hard-wearing stainless steel and come in front and rear mounting styles. The front mounting versions have a low profile bezel that protrudes a maximum of 2,5mm from the front panel, including sealing washer, while the rear mounting version is capable of providing a flush interface when viewed from the front. Both switches make it very difficult for a vandal to get an object behind in order to lever the switch from its mounting.

The 76-95 Series all provide momentary action and are based on our proven Series 16 snap action microswitch. Connections are made via the solder terminals at the rear of the switch.

Mechanical

Operating force	2,6N (typical)
Panel thickness	1,5mm to 8mm (FP) – 15mm button 2,5mm nominal (RP) – 19mm button 1,5mm to 3mm (FP) – 25mm button
Body diameter	M19 thread (FP) – 15mm button 27mm (RP) – 19mm button M30 thread (FP) – 25mm button
Panel cut out	ø19,25mm (FP) – 15mm button ø 22,5mm (RP) – 19mm button ø 30,1mm (FP) – 25mm button
Life (min)	1,000,000 cycles

Electrical

Dielectric strength	1KV AC 1 minute
Insulation resistance	1GΩ @ 500V d.c.
Contact resistance (initial)	25mΩ
Electrical load	10mA 5V d.c. min 10A 250V a.c. max
Life	50,000 cycles (max load) @ 70°C

Environmental & Physical

Ingress protection	IP67 (Panel Sealing)
Operating temperature range	-30°C to +105°C
Body material	Stainless steel
Actuator material	Stainless steel
Contact material	Fine silver
Terminal material	Brass, 5µm bright acid tin plate, nickel flash undercoat

Key

FP	Front Panel Version
RP	Rear Panel Version

Ordering Information

Button Style

Mounting

Switch Element

Panel Mounting

& Construction Information

Panel Mounting Diagrams

Panel Mounting Diagram

Ingress Protection Impact Key

Flush	1	76-95 
Front panel – 15mm button	0	
Rear panel – 19mm button	1	
Front panel – 25mm button	2	
Solder terminals, single pole	4044	

The front panel 76-95 mounts from the front into either a 19,25mm or 30,1mm diameter panel cut out. Panel sealing is achieved by means of a sealing washer which is fitted to the switch body before it is inserted into the panel hole. The switch is then held in place by a lock-nut screwed on from the rear and with the 19,25mm diameter version the microswitch can then be snapped into position at the base of the switch body.

The rear panel 76-95 locates from the rear into a 22,5mm diameter cut out in the front panel. Panel sealing is once again achieved by means of a sealing washer placed over the shoulder of the switch before location. The switch is then clamped in place by a bracket (supplied) fitting over the switch body and two threaded studs pre-welded to the customer's panel. Two nuts then fasten the bracket to the panel and switch allowing access to the switches terminals.

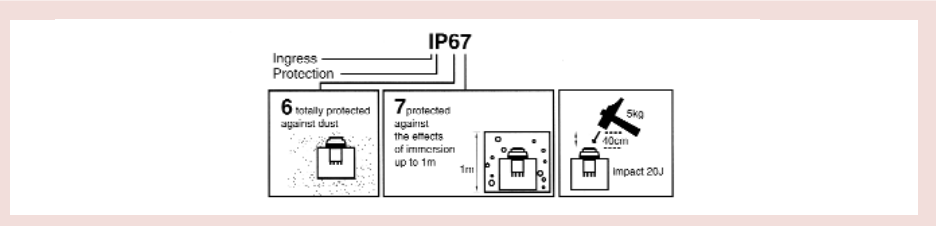
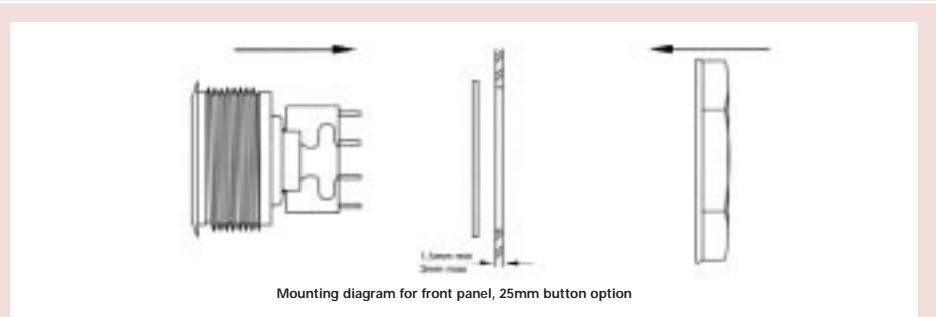
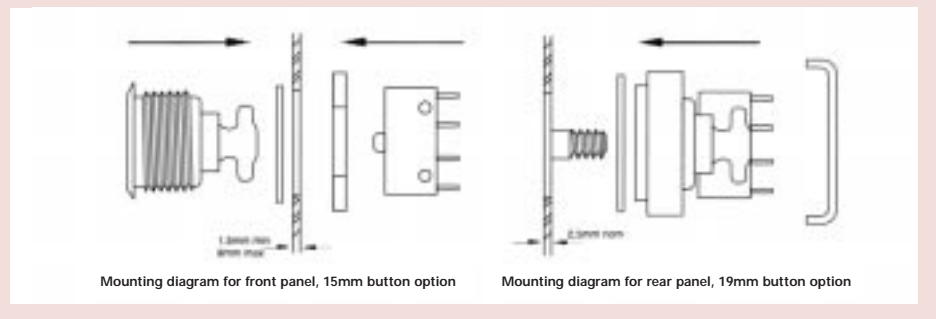

SERIES 76-95

Vandal Resistant Range

Technical Information

Product Drawings

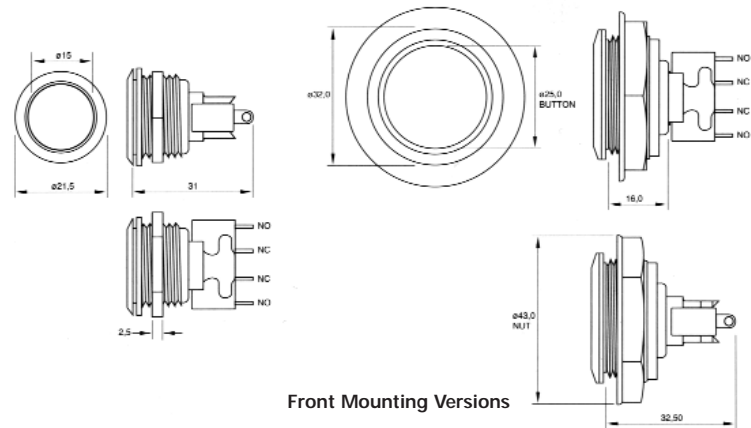

Front Mounting Versions

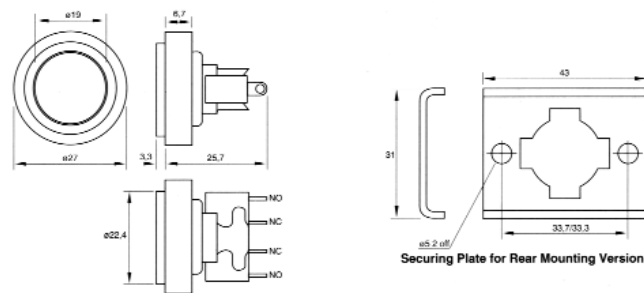

Rear Mounting Version

All dimensions in Millimetres

Circuit Form

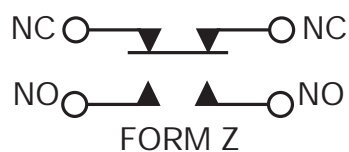

Application References

- Vandal resistant requirements
- Military environments
- Robust industrial requirements
- Flush-with-panel requirements
- Process control
- Railway carriage equipment
- External security door controls
- Elevators
- Fishing vessels
- Crane gantry equipment
- Earth moving equipment
- Upper deck yachting equipment
- Medical instrumentation

Further Information

For further information on our complete range of switch products, visit our website – www.itwswitchcon.com or contact our Sales Office.

ITW Switches

ITW Switches, Division of ITW Limited, Norway Road, Hilsea, Portsmouth PO3 5HT, UK
 Tel: +44 (0)2392 694971 Fax: +44 (0)2392 666352 Website: www.itwswitchcon.com

Due to our policy of continuous product development, ITW Switches retain the right to change the specification at any time without prior notice. Designed & printed in the UK.