

EV-T1G2CC-DC200A-6,0M1ASBK11 - DC charging cable



1101122

<https://www.phoenixcontact.com/us/products/1101122>

Please be informed that the data shown in this PDF document is generated from our online catalog. Please find the complete data in the user documentation. Our general terms of use for downloads are valid.



CHARX connect standard, DC charging cable, with vehicle charging connector and open cable end, for charging electric vehicles (EV) with direct current (DC), with charging connector holder, with analog temperature sensors, CCS type 1, SAE J1772, IEC 62196-3, 200 A / 1000 V (DC), PHOENIX CONTACT logo, cable: 6 m, black, straight

Product description

DC charging cable with vehicle charging connector and free cable end for fast charging of electric vehicles (EV) with direct current (DC) via CCS type 1 vehicle charging inlets, for installation at charging stations for e-mobility (EVSE)

Your advantages

- Complete product range
- The right charging cable for every application, from the carport to the charging park
- Convenient handling due to the ergonomic design
- Available with your logo on request - for consistent branding of your charging station
- Developed and produced in accordance with the IATF 16949 automotive standard and ISO 9001

Commercial data

Item number	1101122
Packing unit	1 pc
Minimum order quantity	1 pc
Sales key	EM01
Product key	XWBAAB
GTIN	4055626957562
Weight per piece (including packing)	13,500 g
Weight per piece (excluding packing)	13,000 g
Customs tariff number	85444290
Country of origin	DE

EV-T1G2CC-DC200A-6,0M1ASBK11 - DC charging cable



1101122

<https://www.phoenixcontact.com/us/products/1101122>

Technical data

Product properties

Product type	DC charging cable
Product family	CHARX connect standard
Application	for charging electric vehicles (EV) with direct current (DC) for installation at charging stations for electromobility (EVSE)
Type	DC charging cable with vehicle charging connector and open cable end
Design	with charging connector holder with analog temperature sensors
Technology	Combined Charging System
Affixed logo	PHOENIX CONTACT logo
Label	8.9 mm x 28.9 mm (customer logo on request)
Charging standard	CCS type 1
Charging mode	Mode 4 DC level 2

Data management status

Article revision	11
------------------	----

Electrical properties

Type of signal transmission	Pulse width modulation with modulated Powerline communication in accordance with ISO/IEC 15118 / DIN SPEC 70121
Note on the connection method	Crimp connection, cannot be disconnected
Coding	480 Ω (Lever actuated) 150 Ω (Lever not actuated)
Temperature monitoring	2x Pt 1000
Type of charging current	DC
Charging power	200 kW
Charging current	200 A
Type of charging current	DC Boost Mode
Charging power	up to 500 kW (Boost Mode, depending on the ambient conditions. For detailed information, see the packing slip in the download area for this item.)
Charging current	up to 500 A (Boost Mode, depending on the ambient conditions. For detailed information, see the packing slip in the download area for this item.)

Power contact

Number	3 (PE, DC+, DC-)
Rated voltage	1000 V DC
Rated current	200 A (up to 40 °C)

Signal contact

EV-T1G2CC-DC200A-6,0M1ASBK11 - DC charging cable



1101122

<https://www.phoenixcontact.com/us/products/1101122>

Number	2 (CP, CS)
Rated voltage	30 V AC
Rated current	2 A

Temperature sensors (Pt 1000)

Sensor type	Pt 1000
Standards/regulations	DIN EN 60751
Attachment point	Sensor for the DC contacts
Switch-off temperature	90 °C ±1 K (equivalent to a Pt 1000 value of 1346.5 Ω)
Long-term stability	0.06 % (after 1000 hours at 130 °C)
Recommended measured current	1 mA (1 V at 0°C)
Coefficient	3850 ppm/K
Ambient temperature	-50 °C ... 130 °C (Operation)

Dimensions

Vehicle charging connector

Width	69.6 mm
Height	192.6 mm
Depth	284.6 mm

Material specifications

Color (Housing)	black (9005)
Color (Handle area)	black (9005)
Color (Mating face)	black (9005)
Color (Protective cap)	black (9005)
Color (Cable)	black (9005)
Material (Vehicle charging connector)	Plastic
Material (Cable outer sheath)	TPE
Material (Contact surface)	Silver
Flammability rating according to UL 94	V0 (Mating face)

Cable/line

Cable length	6 m ±45 mm
Wiring standards/regulations	UL 62 FFSO7.E343212
Cable weight	max. 1900.00 kg/km
Cable type	straight
Cable structure	2 x 1 AWG + 1 x 3 AWG + 3 x 2 x 18 AWG
External cable diameter	35.30 mm ±0.5 mm
Outer sheath, material	TPE
Stripping length of the sheath	180 mm ±10 mm
Stripping length	180 mm ±10 mm
Cable resistance	≤ 0.00044 Ω/m (based on a power core, at an ambient temperature of 20°C)

EV-T1G2CC-DC200A-6,0M1ASBK11 - DC charging cable



1101122

<https://www.phoenixcontact.com/us/products/1101122>

Bending radius	min. 529.5 mm (15x diameter)
----------------	------------------------------

Mechanical properties

Mechanical data

Insertion/withdrawal cycles	> 10000
Insertion force	< 75 N
Withdrawal force	< 75 N

Environmental and real-life conditions

Ambient conditions

Degree of protection (Vehicle charging connector)	IP54 / Type 3R (The degree of protection is only ensured in the ready and plugged-in state when both plug-in components are original products from Phoenix Contact or suitable standard-compliant products.)
Ambient temperature (operation)	-30 °C ... 40 °C max. 55 °C (Current reduction required, observe the DC contact temperature limit value of 90 °C)
Ambient temperature (storage/transport)	-40 °C ... 80 °C
Altitude	5000 m (above sea level)

Standards and regulations

Standards

Standards/regulations	SAE J1772 IEC 62196-3
-----------------------	--------------------------

EV-T1G2CC-DC200A-6,0M1ASBK11 - DC charging cable



1101122

<https://www.phoenixcontact.com/us/products/1101122>

Drawings

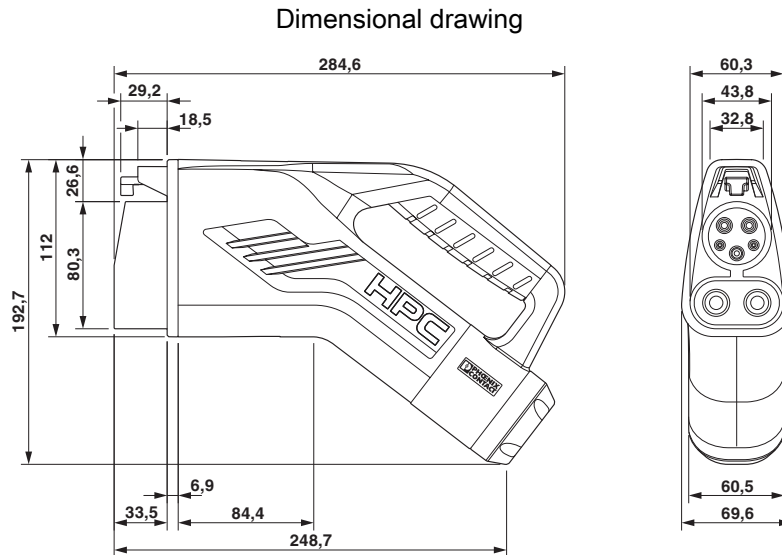

Make sure that the vehicle charging connector is placed in an appropriate charging connector holder, which ensures a minimum protection rating of IP24 in accordance with IEC 61851-1, for the entire time between charging. To create this charging connector holder, use the dimensions of the vehicle charging connector. Detailed dimensions can also be found in the Download area.

EV-T1G2CC-DC200A-6,0M1ASBK11 - DC charging cable

1101122

<https://www.phoenixcontact.com/us/products/1101122>

Schematic diagram

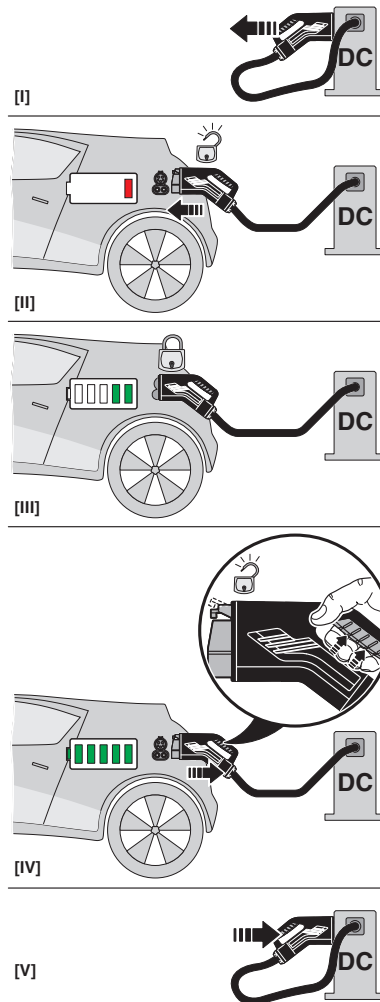

Operating instructions

EV-T1G2CC-DC200A-6,0M1ASBK11 - DC charging cable



1101122

<https://www.phoenixcontact.com/us/products/1101122>

Schematic diagram

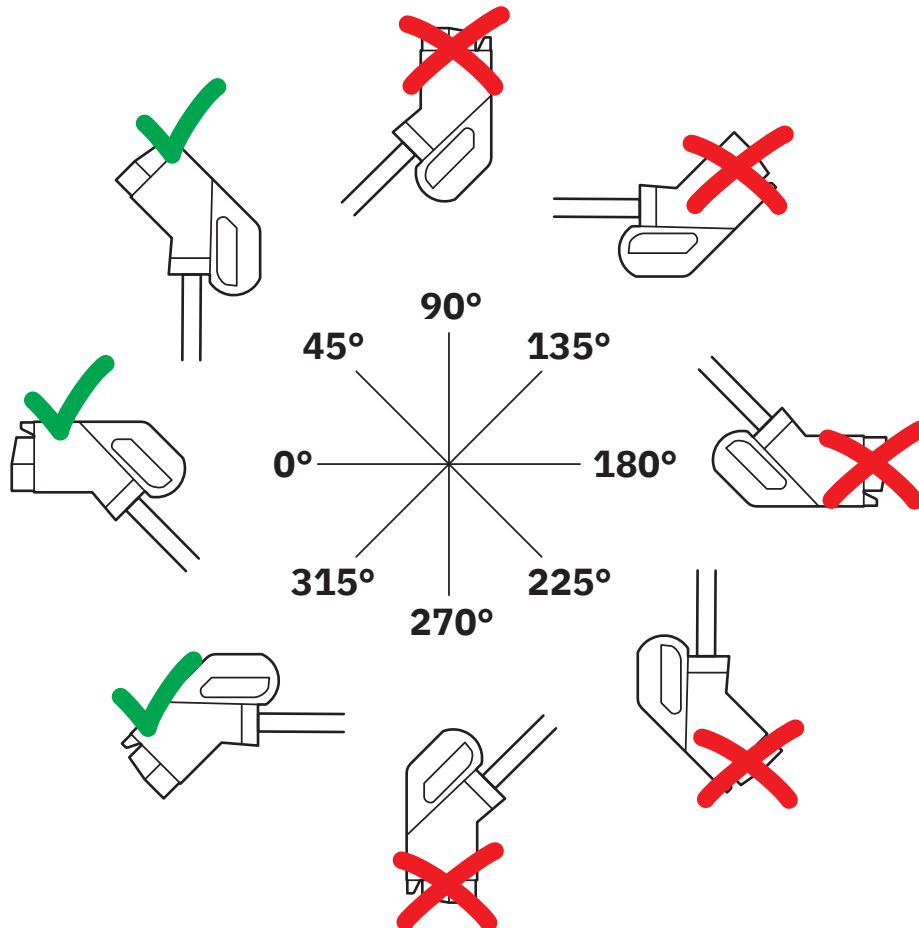

The resting position must be installed in the charging station such that the user cannot hang up the vehicle connector upside down (90° to 270°). However, positions rotated upward (45°) or downward (315°) are options for a resting position.

Schematic diagram

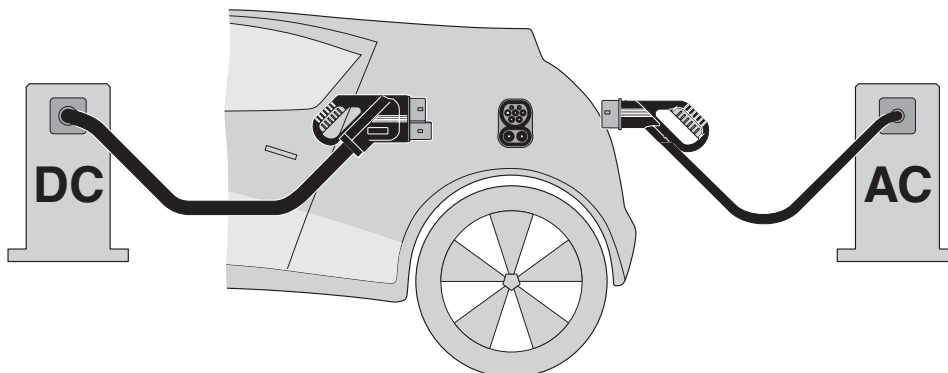

The Combined Charging System (CCS) principle - standard-compliant charging system for electric vehicles, which supports both conventional AC charging and fast DC charging. Both Vehicle Connectors fit into the CCS Vehicle Inlet.

EV-T1G2CC-DC200A-6,0M1ASBK11 - DC charging cable

1101122

<https://www.phoenixcontact.com/us/products/1101122>

Schematic diagram

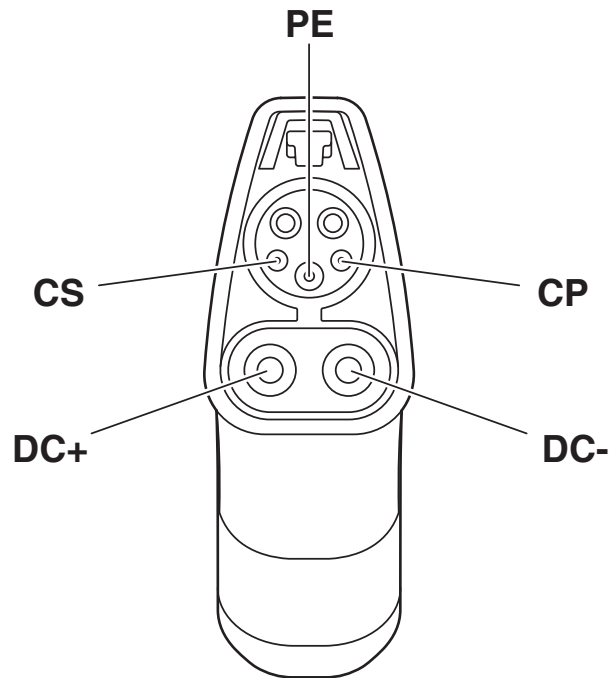

Pin assignment of the Vehicle Connector

EV-T1G2CC-DC200A-6,0M1ASBK11 - DC charging cable



1101122

<https://www.phoenixcontact.com/us/products/1101122>

Approvals

To download certificates, visit the product detail page: <https://www.phoenixcontact.com/us/products/1101122>

 cULus Recognized Approval ID: E473195-20220131				
	Nominal voltage U_N	Nominal current I_N	Cross section AWG	Cross section mm^2
	1000 V	200 A	-	-

EV-T1G2CC-DC200A-6,0M1ASBK11 - DC charging cable



1101122

<https://www.phoenixcontact.com/us/products/1101122>

Classifications

ECLASS

ECLASS-11.0	27144705
ECLASS-12.0	27144705
ECLASS-13.0	27144705

ETIM

ETIM 9.0	EC002897
----------	----------

UNSPSC

UNSPSC 21.0	39121500
-------------	----------

EV-T1G2CC-DC200A-6,0M1ASBK11 - DC charging cable



1101122

<https://www.phoenixcontact.com/us/products/1101122>

Environmental product compliance

EU RoHS

Fulfills EU RoHS substance requirements	Yes, No exemptions
---	--------------------

China RoHS

Environment friendly use period (EFUP)	EFUP-10
	An article-related China RoHS declaration table can be found in the download area for the respective article under "Manufacturer declaration". For all articles with EFUP-E, no China RoHS declaration table issued and required.

EU REACH SVHC

REACH candidate substance (CAS No.)	No substance above 0.1 wt%
-------------------------------------	----------------------------

EV-T1G2CC-DC200A-6,0M1ASBK11 - DC charging cable



1101122

<https://www.phoenixcontact.com/us/products/1101122>

Accessories

EV-T1CCS-PARK - Charging connector holder

1624143

<https://www.phoenixcontact.com/us/products/1624143>



CHARX connect, Charging connector holder, Accessories, for vehicle charging connectors on charging stations (EVSE), CCS type 1, SAE J1772, Front mounting, housing: black

EV-T1CCS-MF-M4X10-BIT-C - Repair kit

1158266

<https://www.phoenixcontact.com/us/products/1158266>



CHARX connect standard, Repair kit, Accessories, with DC contact holder with integrated front part of the DC contacts, with replaceable mating face frame, with 5x M4X10 flat-head screws with Torx safety drive (IPR TORX PLUS®), with special bit (867/4 IPR TORX PLUS® bit, 20 IPR x 89 mm) for insulated screwdriver, for replacement of the mating face frame of vehicle charging connectors, CCS type 1, IEC 62196-3, SAE J1772, Screw mounting, housing: black, The vehicle connector housing does not have to be opened in order to replace the mating face frame.

EV-T1G2CC-DC200A-6,0M1ASBK11 - DC charging cable



1101122

<https://www.phoenixcontact.com/us/products/1101122>

EV-T1CCS-MF-M4X10-C - Repair kit

1288248

<https://www.phoenixcontact.com/us/products/1288248>



CHARX connect standard, Repair kit, Accessories, with DC contact holder with integrated front part of the DC contacts, with replaceable mating face frame, with 5x M4X10 flat-head screws with Torx safety drive (IPR TORX PLUS®), for replacement of the mating face frame of vehicle charging connectors, CCS type 1, IEC 62196-3, SAE J1772, Screw mounting, housing: black, The vehicle connector housing does not have to be opened in order to replace the mating face frame.

EV-T1CCS-MF-M4X10-BIT - Repair kit

1085801

<https://www.phoenixcontact.com/us/products/1085801>



CHARX connect, Repair kit, Accessories, with replaceable mating face frame, with 5x M4X10 flat-head screws with Torx safety drive (IPR TORX PLUS®), with special bit (867/4 IPR TORX PLUS® bit, 20 IPR x 89 mm) for insulated screwdriver, for replacement of the mating face frame of vehicle charging connectors, CCS type 1, IEC 62196-3-1, SAE J1772, Screw mounting, housing: black, Replacement without draining the coolant

EV-T1G2CC-DC200A-6,0M1ASBK11 - DC charging cable



1101122

<https://www.phoenixcontact.com/us/products/1101122>

EV-T1CCS-MF-M4X10 - Repair kit

1085800

<https://www.phoenixcontact.com/us/products/1085800>



CHARX connect, Repair kit, Accessories, with replaceable mating face frame, with 5x M4X10 flat-head screws with Torx safety drive (IPR TORX PLUS®), for replacement of the mating face frame of vehicle charging connectors, CCS type 1, IEC 62196-3-1, SAE J1772, Screw mounting, housing: black, Replacement without draining the coolant

EV-T1CCS-M4X20-BIT-C - Repair kit

1288250

<https://www.phoenixcontact.com/us/products/1288250>



CHARX connect standard, Repair kit, Accessories, with DC contact holder with integrated front part of the DC contacts, with special bit (867/4 IPR TORX PLUS® bit, 20 IPR x 89 mm) for insulated screwdriver, CCS type 1, IEC 62196-3, SAE J1772, Screw mounting, housing: black

EV-T1G2CC-DC200A-6,0M1ASBK11 - DC charging cable



1101122

<https://www.phoenixcontact.com/us/products/1101122>

EV-T1CCS-M4X20-C - Repair kit

1288247

<https://www.phoenixcontact.com/us/products/1288247>



CHARX connect standard, Repair kit, Accessories, with DC contact holder with integrated front part of the DC contacts, CCS type 1, IEC 62196-3, SAE J1772, Screw mounting, housing: black

G-INSEC-M63-L68N-NCRS-S - Cable gland

1411194

<https://www.phoenixcontact.com/us/products/1411194>



Cable gland, material for screw connection: Brass, nickel-plated, application: EMC, external cable diameter 32 mm ... 42 mm, shielding: yes, connecting thread: M63 x 1.5, color: silver, with O-ring

EV-T1G2CC-DC200A-6,0M1ASBK11 - DC charging cable



1101122

<https://www.phoenixcontact.com/us/products/1101122>

CHARX PS-M2/3AC/1000DC/30KW - DC power module

1232243

<https://www.phoenixcontact.com/us/products/1232243>

CHARX power basic, Fast charging module for setting up DC charging stations, 19" rack mounting, input: 3-phase, output: 30 V DC...1000 V DC / 0 A...100 A



CHARX PS-M2/825DC/1000DC/30KW - DC power module

1296467

<https://www.phoenixcontact.com/us/products/1296467>

CHARX power basic, Fast charging module for setting up DC charging stations, 19" rack mounting, output: 30 V DC...1000 V DC / 0 A...100 A



Phoenix Contact 2024 © - all rights reserved
<https://www.phoenixcontact.com>

Phoenix Contact USA
586 Fulling Mill Road
Middletown, PA 17057, United States
(+717) 944-1300
info@phoenixcon.com